

1

Figure 1 shows a straight wire passing through a piece of card.

A current (I) is passing down through the wire.

Figure 1

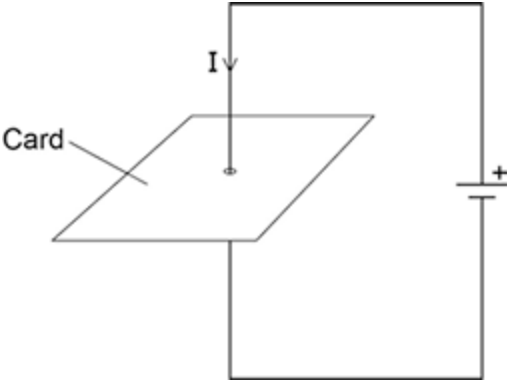

(a) Describe how you could show that a magnetic field has been produced around the wire.

.....

.....

.....

.....

(2)

(b) **Figure 2** shows the ignition circuit used to switch the starter motor in a car on.

The circuit includes an electromagnetic switch.

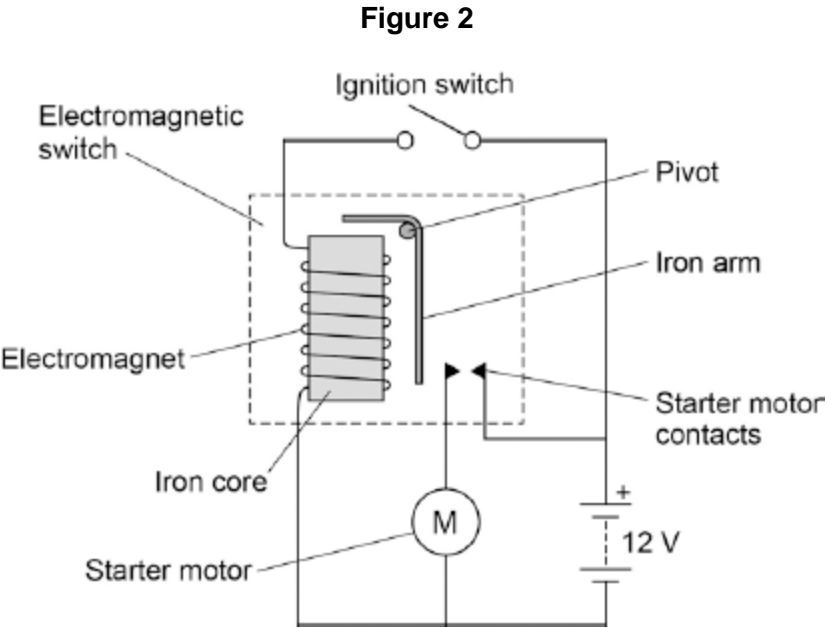

Explain how the ignition circuit works.

.....

.....

.....

.....

.....

.....

.....

.....

.....

(4)
(Total 6 marks)

2

Figure 1 shows a straight wire passing through a piece of card.

A current (I) is passing down through the wire.

Figure 1

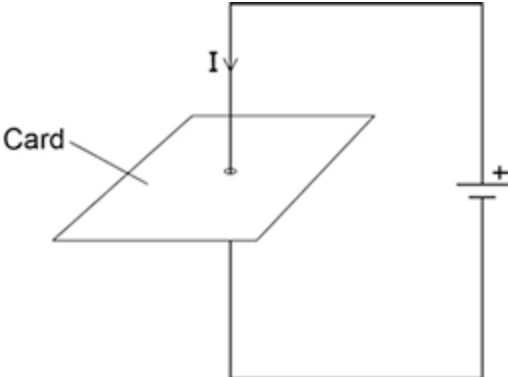

(a) Describe how you could show that a magnetic field has been produced around the wire.

.....

.....

.....

.....

(2)

(b) **Figure 2** shows the ignition circuit used to switch the starter motor in a car on.

The circuit includes an electromagnetic switch.

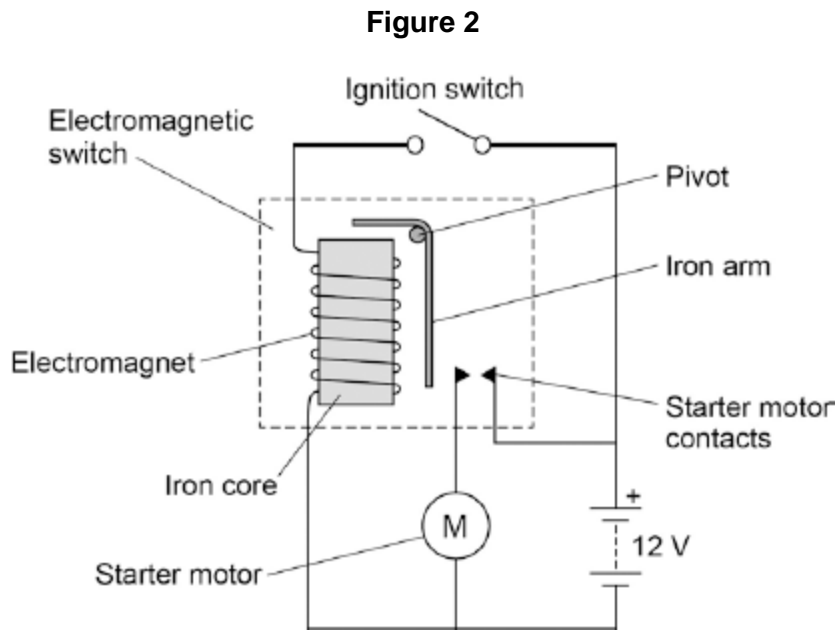

Explain how the ignition circuit works.

.....

.....

.....

.....

.....

.....

.....

.....

.....

(4)
(Total 6 marks)

3

Figure 1 shows a piece of apparatus called a current balance.

Figure 1

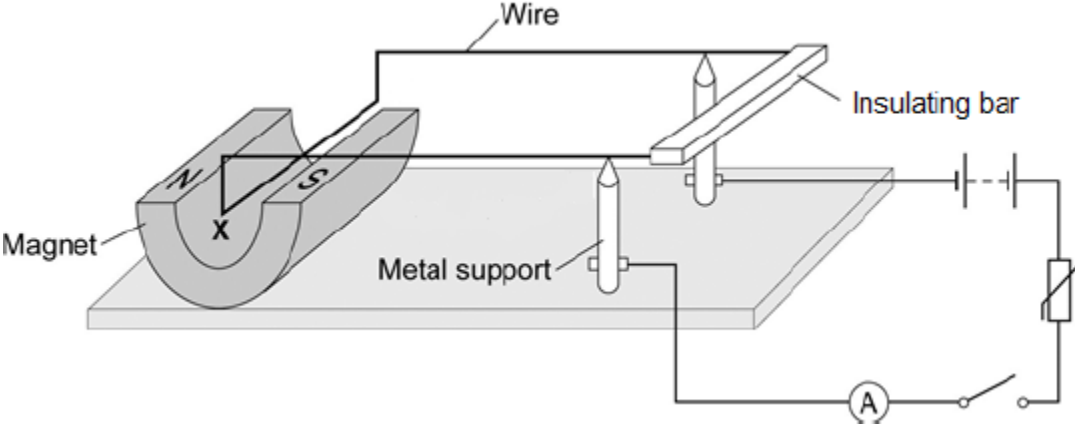

When the switch is closed, the part of the wire labelled X experiences a force and moves downwards.

(a) What is the name of the effect that causes the wire X to move downwards?

.....

(1)

(b) Suggest one change you could make to the apparatus in Figure 1 that would increase the size of the force that wire X experiences.

.....

(1)

- (c) **Figure 2** shows how a small weight placed on the insulating bar makes the wire **X** go back and balance in its original position.

Figure 2

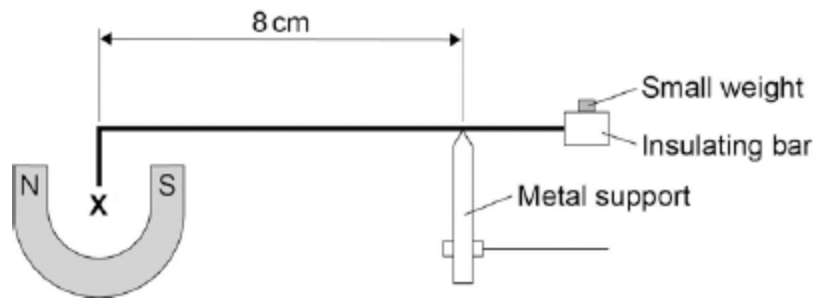

The wire **X** is 5 cm long and carries a current of 1.5 A.

The small weight causes a clockwise moment of 4.8×10^{-4} Nm.

Calculate the magnetic flux density where the wire **X** is positioned

Give the unit.

.....

.....

.....

.....

.....

.....

.....

.....

Magnetic flux density = Unit

(6)
(Total 8 marks)

4

Musicians sometimes perform on a moving platform.

Figure 1 shows the parts of the lifting machine used to move the platform up and down.

Figure 1

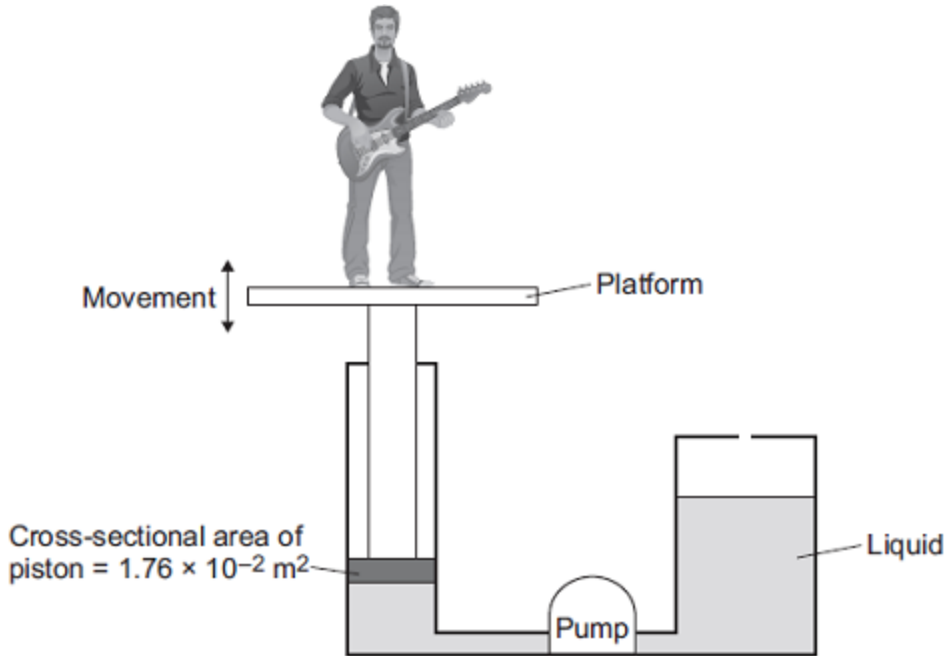

(a) What type of system uses a liquid to transmit a force?

.....

(1)

(b) The pump creates a pressure in the liquid of $8.75 \times 10^4 \text{ Pa}$ to move the platform upwards. Calculate the force that the liquid applies to the piston.

.....
.....
.....

Force = N

(2)

- (c) The liquid usually used in the machine is made by processing oil from underground wells. A new development is to use plant oil as the liquid.

Extracting plant oil requires less energy than extracting oil from underground wells.

Suggest an environmental advantage of using plant oil.

.....

.....

.....

(1)

(d) Musicians often use loudspeakers.

Figure 2 shows how a loudspeaker is constructed.

Figure 2

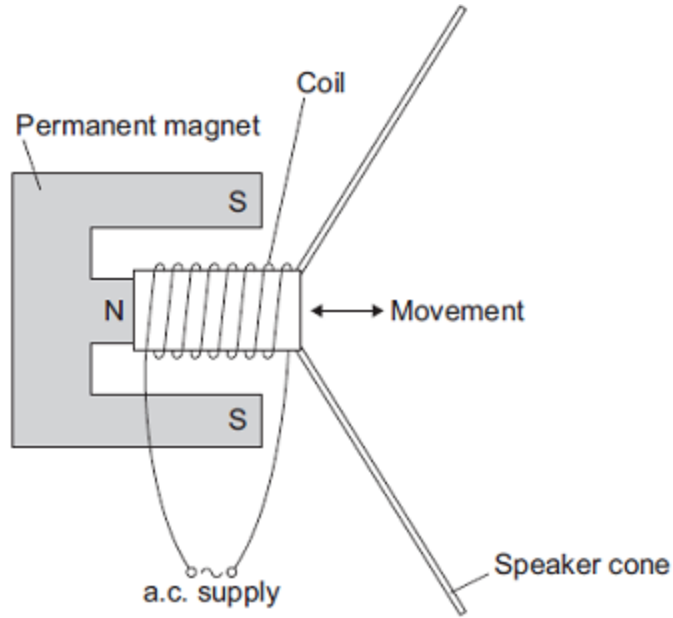

The loudspeaker cone vibrates when an alternating current flows through the coil.

Explain why.

.....

.....

.....

.....

.....

.....

.....

.....

.....

.....

.....

(4)
(Total 8 marks)

5

(a) Some people wear magnetic bracelets to relieve pain.

Figure 1 shows a magnetic bracelet.

There are magnetic poles at both **A** and **B**.
Part of the magnetic field pattern between **A** and **B** is shown.

Figure 1

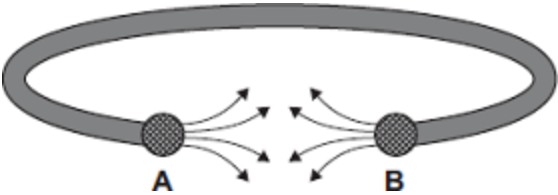

What is the pole at **A**?

What is the pole at **B**?

(1)

(b) **Figure 2** shows two of the lines of the magnetic field pattern of a current-carrying wire.

Figure 2

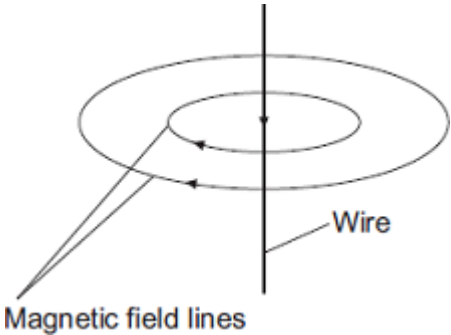

The direction of the current is reversed.

What happens to the direction of the lines in the magnetic field pattern?

.....

(1)

(c) Fleming's left-hand rule can be used to identify the direction of a force acting on a current-carrying wire in a magnetic field.

(i) Complete the labels in **Figure 3**.

Figure 3

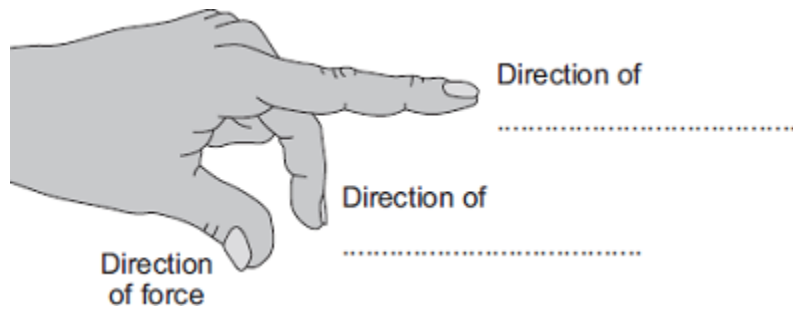

(2)

(ii) **Figure 4** shows:

- the direction of the magnetic field between a pair of magnets
- the direction of the current in a wire in the magnetic field.

Figure 4

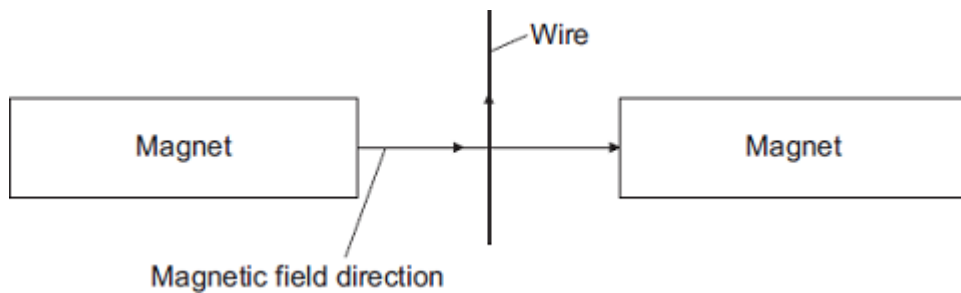

In which direction does the force on the wire act?

.....

(1)

(iii) Suggest **three** changes that would **decrease** the force acting on the wire.

1

2

3

(3)

- (d) **Figure 5** shows part of a moving-coil ammeter as drawn by a student.

The ammeter consists of a coil placed in a uniform magnetic field.

When there is a current in the coil, the force acting on the coil causes the coil to rotate and the pointer moves across the scale.

Figure 5

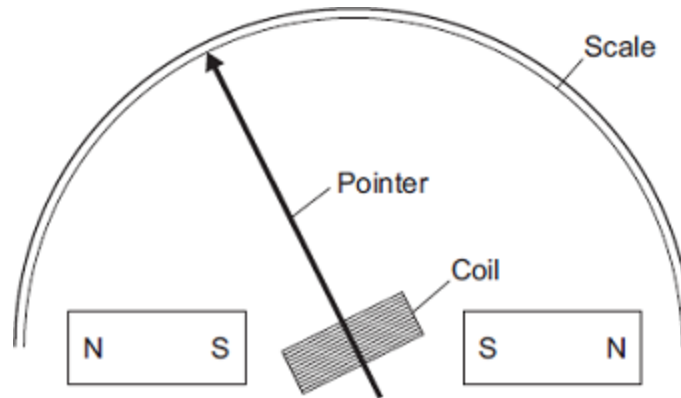

- (i) The equipment has **not** been set up correctly.

What change would make it work?

.....

(1)

- (ii) **Figure 6** shows the pointer in an ammeter when there is no current.

Figure 6

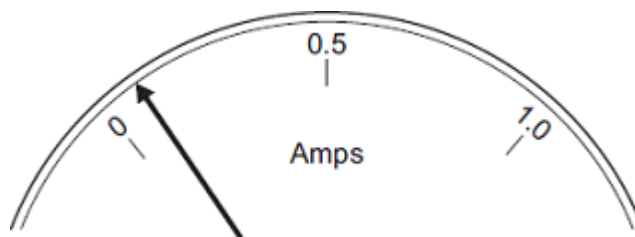

What type of error does the ammeter have?

.....

(1)
 (Total 10 marks)

6

The diagram shows a 'G-machine'. The G-machine is used in astronaut training.

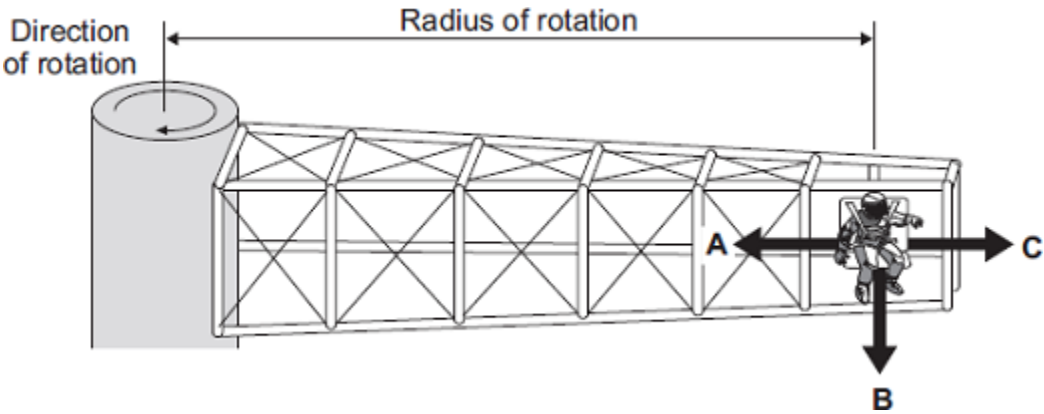

The G-machine moves the astronaut in a horizontal circle.

Force A is known as the **centripetal** force acting on the astronaut

(a) The centripetal force on the astronaut is measured.

Graph X shows how the centripetal force is affected by the speed of rotation. The radius of rotation is kept the same.

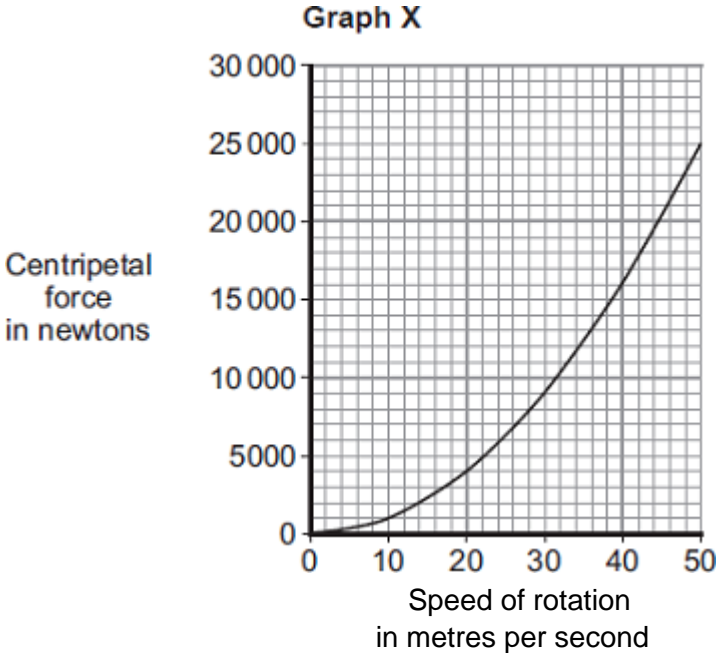

(i) Use **Graph X** to determine the centripetal force on the astronaut when rotating at a speed of 30 metres per second.

Centripetal force = newtons

(1)

- (ii) Complete the following sentence to give the conclusion that can be made from **Graph X**.

Increasing the speed of rotation of a G-machine will
the centripetal force on the astronaut.

(1)

- (iii) **Graph Y** shows how the centripetal force is affected by the radius of rotation, when the speed of rotation is kept the same.

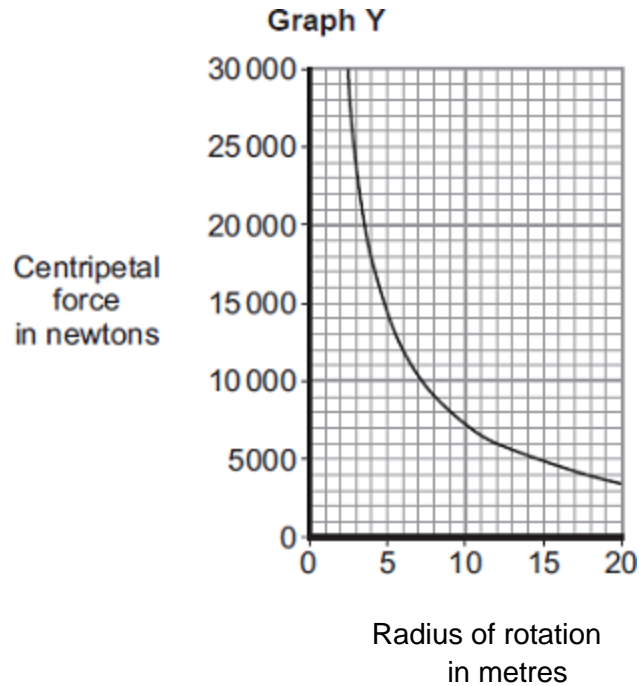

Complete the following sentence to give the conclusion that can be made from **Graph Y**.

The greater the radius of rotation, the the centripetal force on the astronaut.

(1)

(b) The G-machine is rotated by an electric motor. The diagram shows a simple electric motor.

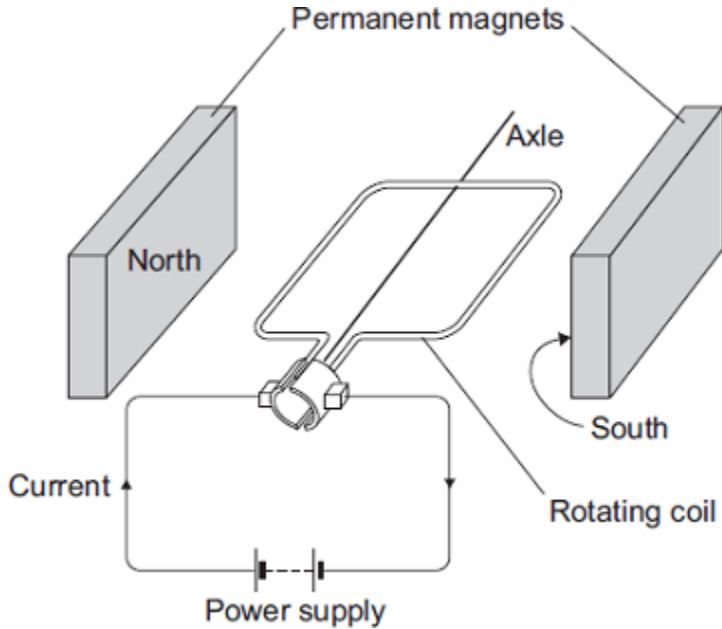

The following statements explain how the motor creates a turning force. The statements are in the wrong order.

- M** – The magnetic field interacts with the magnetic field of the permanent magnets.
- N** – A magnetic field is created around the coil.
- O** – The power supply applies a potential difference across the coil.
- P** – This creates a force that makes the coil spin.
- Q** – A current flows through the coil.

Arrange the statements in the correct order. Two of them have been done for you.



(2)

(c) The electric motor produces a turning force.

Give **two** ways of increasing the turning force.

- 1
-
- 2
-

(2)

(d) Draw a ring around the correct answer to complete the sentence.

It costs a lot of money to send astronauts into space.

This is

an economic
an environmental
a social

 issue.

(1)
(Total 8 marks)

7

The diagram shows a 'G-machine'. The G-machine is used in astronaut training.

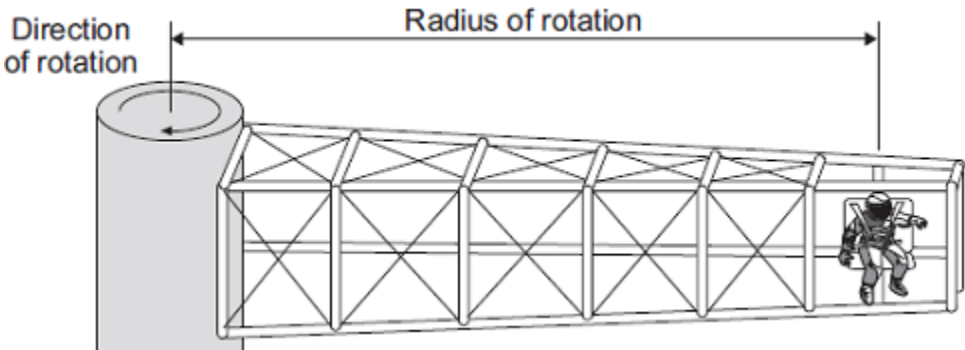

The G-machine moves the astronaut in a horizontal circle.

(a) The force causing the astronaut to move in a circle is measured.

The graph shows how the speed of the astronaut affects the force causing the astronaut to move in a circle for two different G-machines.

The radius of rotation of the astronaut is different for each G-machine.

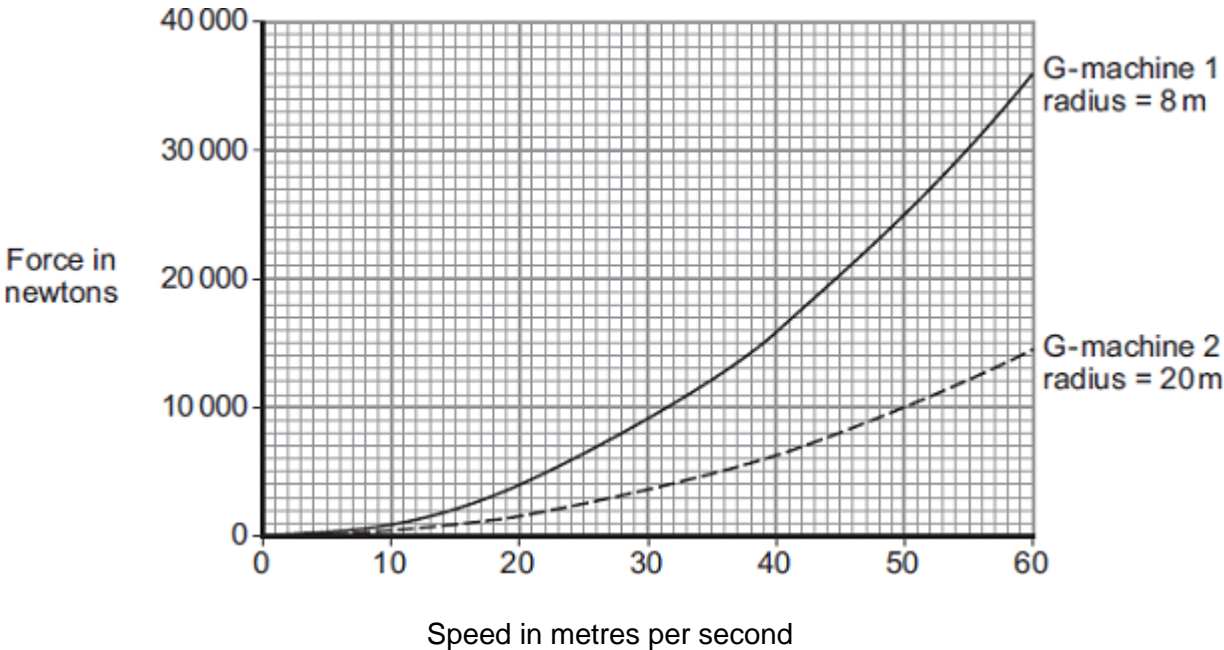

(i) State **three** conclusions that can be made from the graph.

- 1
- 2
- 3

(3)

- (ii) The speed of rotation of G-machine 1 is increased from 20 m/s to 40 m/s.

Determine the change in force on the astronaut.

.....

Change in force = N

(1)

- (b) Each G-machine is rotated by an electric motor. The diagram shows a simple electric motor.

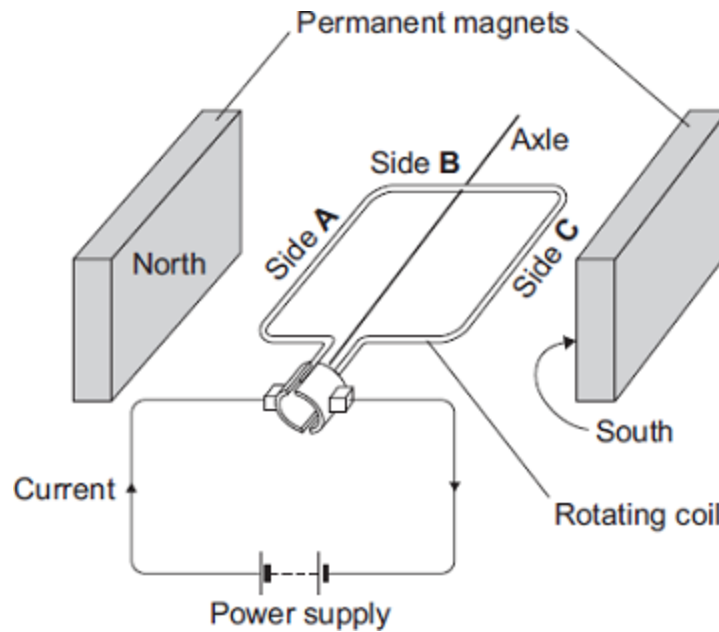

- (i) A current flows through the coil of the motor.

Explain why side **A** of the coil experiences a force.

.....

(2)

- (ii) Draw arrows on the diagram to show the direction of the forces acting on side **A** of the coil and side **C** of the coil.

(1)

- (iii) When horizontal, side **B** experiences no force.

Give the reason why.

.....

(1)

(c) While a G-machine is rotating, the operators want to increase its speed.

What can the operators do to make the G-machine rotate faster?

.....
.....

(1)

(d) The exploration of space has cost a lot of money.

Do you think spending lots of money on space exploration has been a good thing?

Draw a ring around your answer.

Yes **No**

Give a reason for your answer.

.....
.....

(1)

(Total 10 marks)

8

A student has made a simple electric motor. The diagram shows the electric motor.

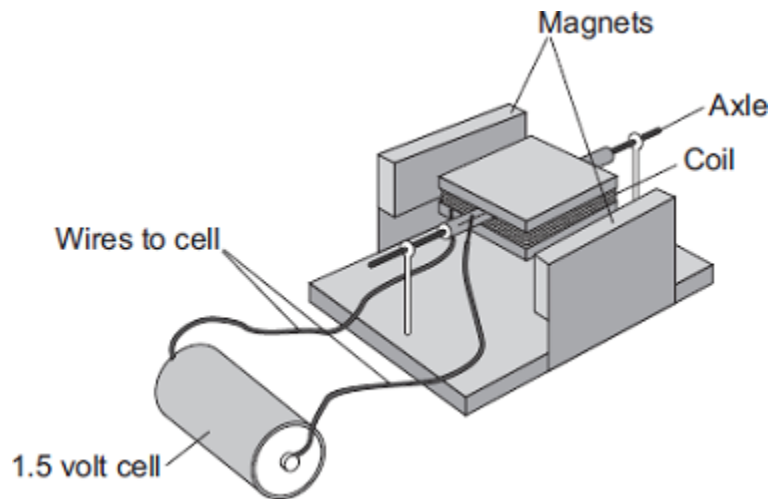

(a) Complete the following sentence by drawing a ring around the correct line in the box.

Once the coil is spinning, one side of the coil is pushed by

- the cell
- the coil
- a force

and the other

side is pulled, so the coil continues to spin.

(1)

(b) Suggest **two** changes to the electric motor, each one of which would make the coil spin faster.

1

.....

2

.....

(2)

(c) Suggest **two** changes to the electric motor, each one of which would make the coil spin in the opposite direction.

1

.....

2

.....

(2)

(Total 5 marks)

9

The diagram shows a device called a current balance.

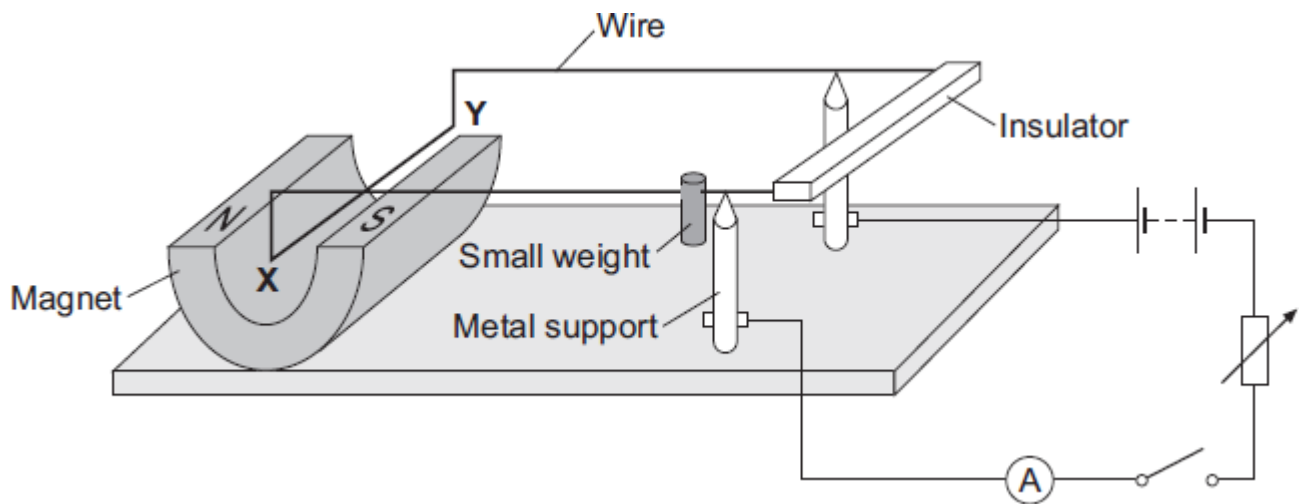

(a) (i) When the switch is closed, the part of the wire labelled **XY** moves upwards.

Explain why.

.....

.....

.....

.....

(2)

(ii) What is the name of the effect that causes the wire **XY** to move?

.....

(1)

(iii) An alternating current (a.c.) is a current which reverses direction. How many times the current reverses direction in one second depends on the frequency of the alternating supply.

Describe the effect on the wire **XY** if the battery is replaced by an a.c. supply having a frequency of 5 hertz.

.....

.....

.....

.....

(2)

- (b) The diagram shows how a small weight can be used to make the wire **XY** balance horizontally.

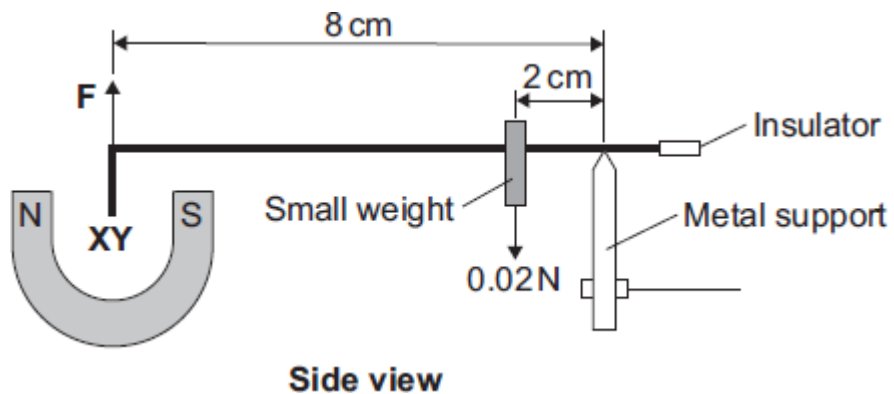

Use the data in the diagram and the equation in the box to calculate the force, **F**, acting on the wire **XY**.

moment = force × perpendicular distance from the line of action of the force to the axis of rotation

Show clearly how you work out your answer.

.....

.....

.....

.....

Force = N

(3)
(Total 8 marks)

10

(a) Complete the description of the device shown below by drawing a ring around the correct line in each box.

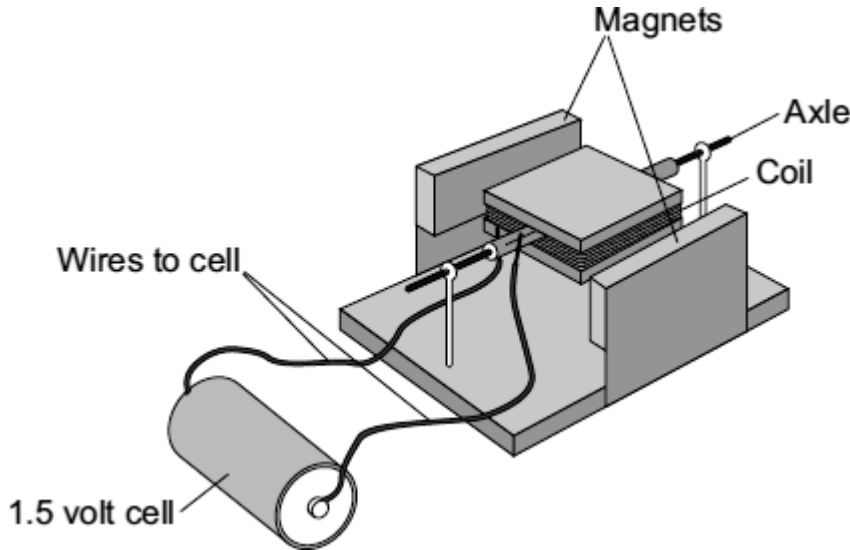

(i) The device is being used as

an electric motor.
a generator.
a transformer.

(1)

(ii) The coil needs a flick to get started. Then one side of the coil is pushed by the

cell
coil
force

and the other side is pulled, so that the coil spins.

(1)

(b) Suggest **two** changes to the device, each one of which would make the coil spin faster.

- 1
-
- 2
-

(2)

- (c) Suggest **two** changes to the device, each one of which would make the coil spin in the opposite direction.

1

.....

2

.....

(2)
(Total 6 marks)

11

- (a) A science technician sets up the apparatus shown below to demonstrate the motor effect. He uses a powerful permanent magnet.

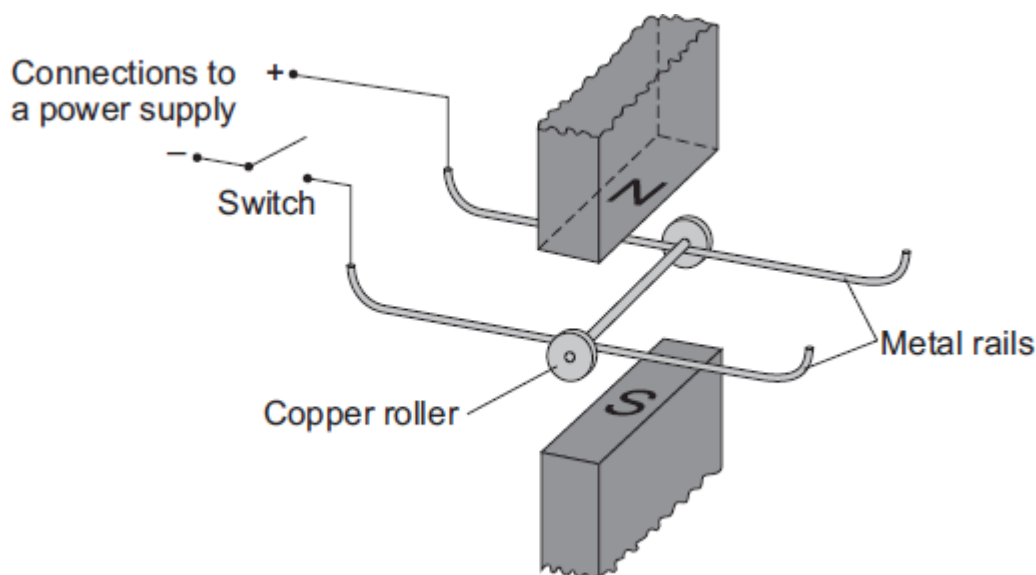

The copper roller is placed across the metal rails. When the switch is closed, the copper roller moves to the right.

- (i) Complete the sentence by drawing a ring around the correct line in the box.

This happens because copper is

an electrical conductor.

an electrical insulator.

a magnetic material.

(1)

(ii) Suggest **one** change that the technician can make which will cause the copper roller to move faster.

.....
.....

(1)

(iii) Suggest **two** changes which the technician can make, each of which will separately cause the copper roller to move to the left.

1

.....

2

.....

(2)

(b) Many electrical appliances, such as vacuum cleaners, drills and CD players, contain electric motors. As more electrical appliances are developed, more electricity needs to be generated. Generating electricity often produces pollutant gases.

(i) Complete the sentence by drawing a ring around the correct line in the box.

Generating more electricity to power the increasing number of electrical appliances used

raises

an ethical
an environmental
a political

 issue.

(1)

(ii) The number of electrical appliances used in the world's richest countries is increasing yet many people in the world's poorest countries have no access to electricity.

What type of issue does this inequality between people in different countries raise?

.....

(1)

(Total 6 marks)

12

A student investigates the electromagnetic force acting on a wire which carries an electric current. The wire is in a magnetic field.

The diagram shows the circuit which the student uses.

- (a) Draw an **X** on the diagram, with the centre of the **X** in the most strongest part of the magnetic field.

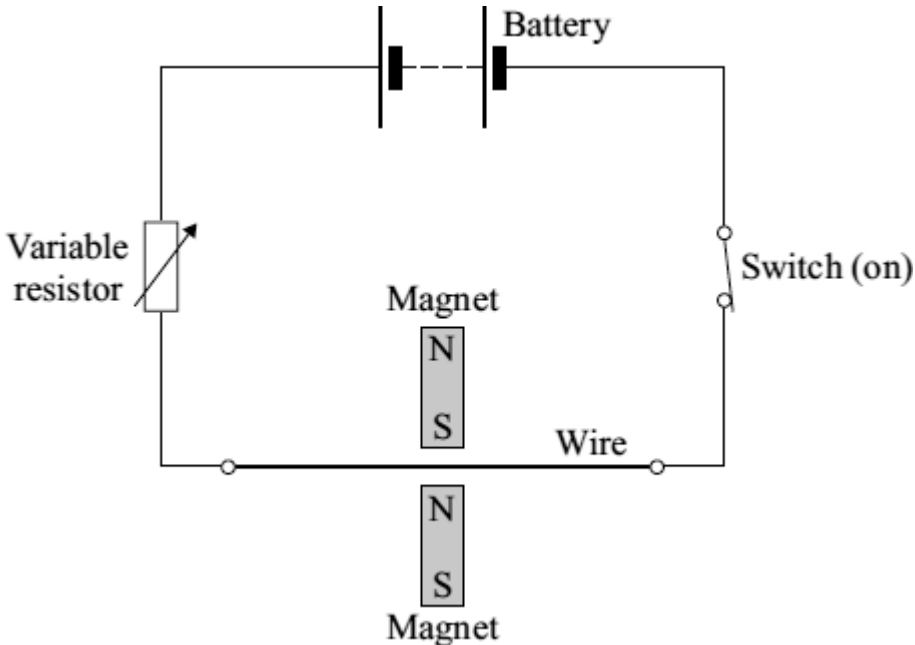

(1)

- (b) Give **one** change that she can make to the magnets to **decrease** the electromagnetic force on the wire.

.....

.....

(1)

- (c) The student wants to change the electromagnetic force on the wire without changing the magnets or moving their position.

- (i) Give **one** way in which she can **increase** the electromagnetic force.

.....

.....

(1)

(ii) Give **one** way in which she can **reverse** the direction of the electromagnetic force.

.....
.....

(1)
(Total 4 marks)

13

(a) A laboratory technician sets up a demonstration.

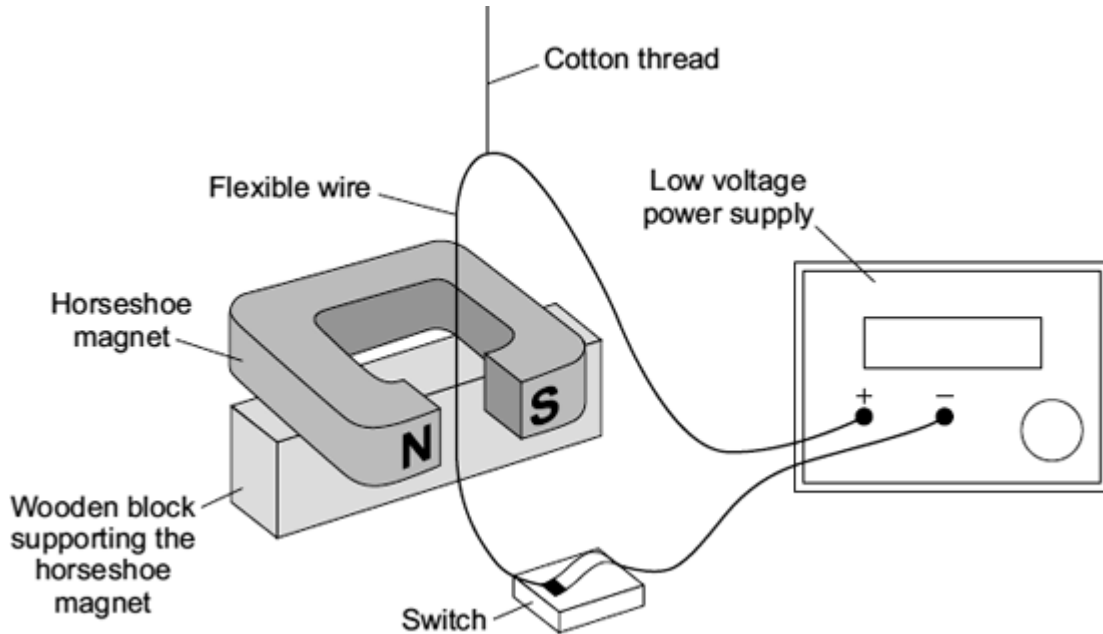

A flexible wire is suspended between the ends of a horseshoe magnet. The flexible wire hangs from a cotton thread. When the switch is closed, the wire kicks forward.

Identify the effect which is being demonstrated.

.....

(1)

(b) A teacher makes some changes to the set-up of the demonstration.

What effect, if any, will each of the following changes have?

(i) more powerful horseshoe magnet is used.

.....
.....

(1)

(ii) The connections to the power supply are reversed.

.....
.....

(1)
(Total 3 marks)

14

Many electrical appliances use the circular motion produced by their electric motor.

(a) Put ticks (✓) in the boxes next to **all** the appliances in the list which have an electric motor.

electric drill

electric fan

electric food mixer

electric iron

electric kettle

electric screwdriver

(2)

- (b) One simple design of an electric motor is shown in the diagram. It has a coil which spins between the ends of a magnet.

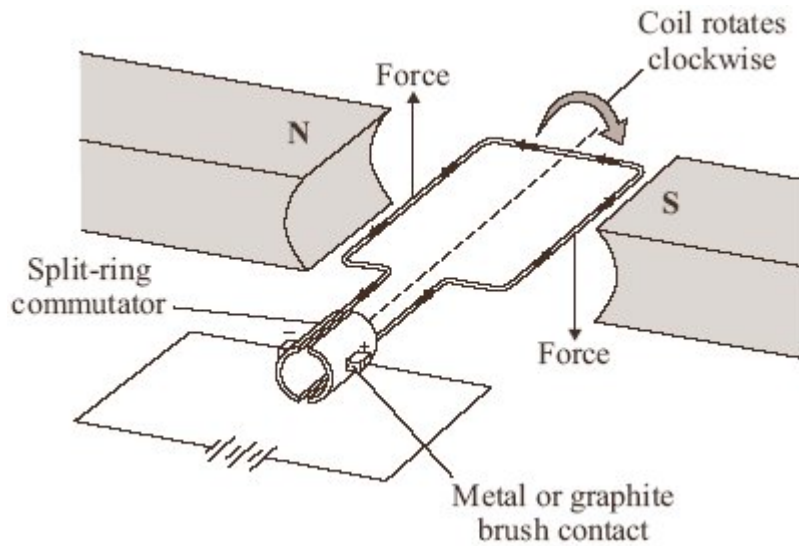

- (i) Give **two** ways of reversing the direction of the forces on the coil in the electric motor.

1

.....

2

.....

(2)

- (ii) Give **two** ways of increasing the forces on the coil in the electric motor.

1

.....

2

.....

(2)

(Total 6 marks)

15

When a conductor carrying an electric current is placed in a magnetic field a force may act on it.

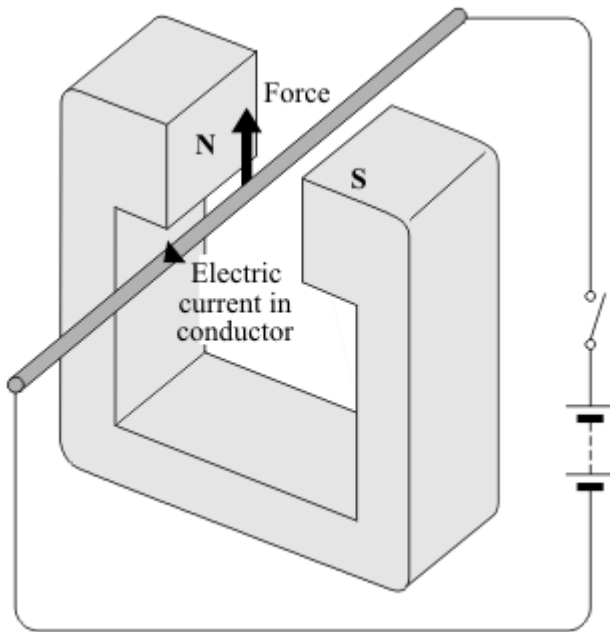

(a) State **two** ways in which this force can be increased.

1

2

(2)

(b) State **two** ways in which this force can be made to act in the opposite direction.

1

2

(2)

(c) In what circumstance will **no** force act on a conductor carrying an electric current and in a magnetic field?

.....

.....

(1)

(Total 5 marks)

Show clearly how you work out your answer.

.....
.....

Kinetic energy = J

(2)
(Total 7 marks)

16

The diagram shows the design for a remotely controlled door bolt.

When the correct numbers are entered into the keypad the transformer switches on. Then the door can be opened.

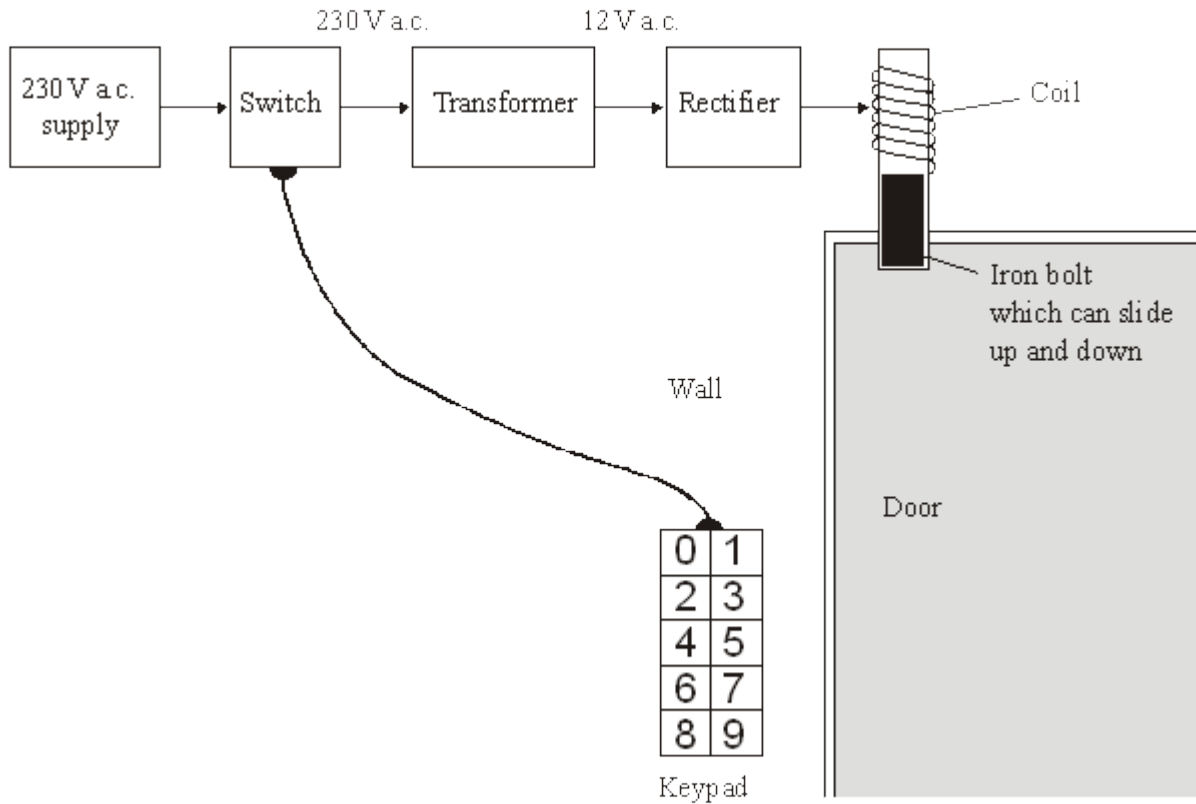

(a) What kind of transformer is shown in the diagram?

.....

(1)

(b) What does the abbreviation a.c. stand for?

.....

(1)

(c) Complete the sentences using the correct words from the box.

attracts	downwards	magnet	reflects	repels
sideways	switch	transformer	upwards	

- (i) When a current flows in the coil, the coil becomes a
- (ii) The coil the iron bolt which moves

(3)
(Total 5 marks)

17

The diagram shows apparatus used to demonstrate the electric motor effect. When the switch is closed the wire moves.

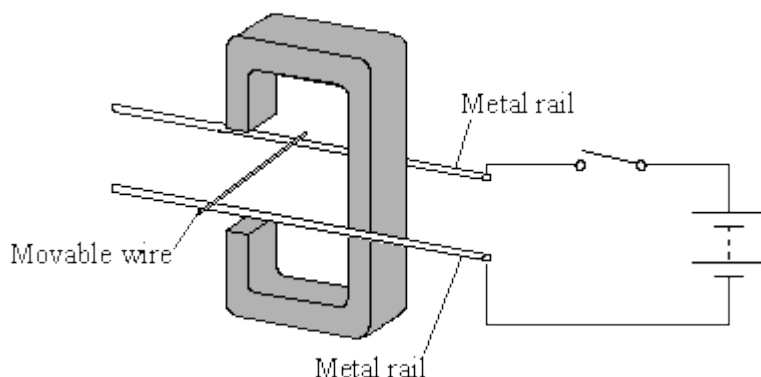

- (i) Draw an arrow on the diagram to show the direction the wire moves.

(1)

- (ii) Explain why the wire moves.

.....
.....
.....
.....

(2)
(Total 3 marks)

18

The diagram shows apparatus used to demonstrate the motor effect. X is a short length of bare copper wire resting on two other wires.

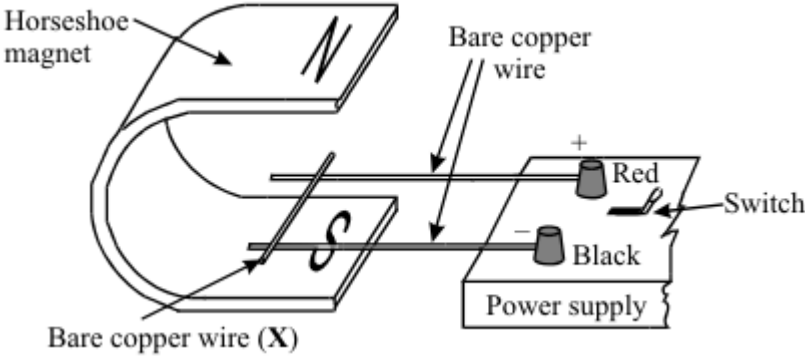

(a) (i) Describe what happens to wire X when the current is switched on.

.....
.....
.....

(ii) What difference do you notice if the following changes are made?

A The magnetic field is reversed.

.....
.....

B The current is increased.

.....
.....

(3)

(b) The diagram shows a coil placed between the poles of a magnet. The arrows on the sides of the coil itself show the direction of the conventional current.

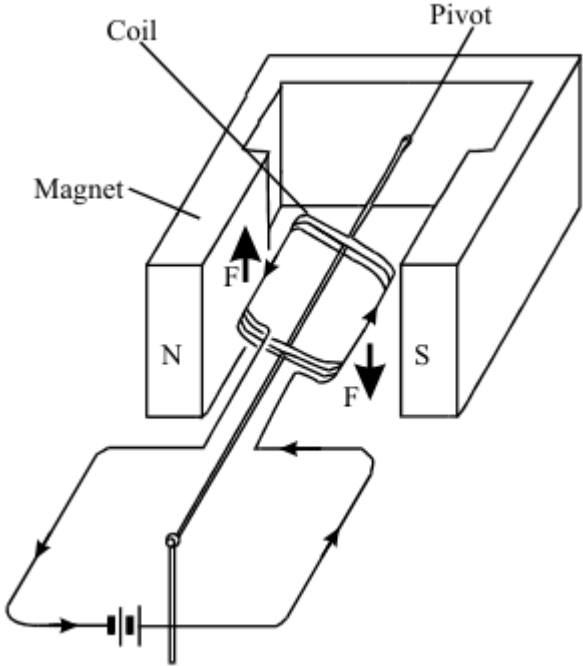

The arrows labelled **F** show the direction of the forces acting on the sides of the coil. Describe the motion of the coil until it comes to rest.

.....

.....

.....

.....

.....

(3)

(c) Most electric motors use electromagnets instead of permanent magnets. State three of the features of an electromagnet which control the strength of the magnetic field obtained.

1

2

3

(3)
(Total 9 marks)

Mark schemes

1

- (a) move a (magnetic / plotting) compass around the wire

1

the changing direction of the compass needle shows a magnetic field has been produced

OR

sprinkle iron filings onto the card (1)

tapping the card will move the filings to show the magnetic field (pattern) (1)

1

- (b) **Level 2 (3–4 marks):**

A detailed and coherent explanation is provided. The response makes logical links between clearly identified, relevant points that explain how the ignition circuit works.

Level 1 (1–2 marks):

Simple statements are made. The response may fail to make logical links between the points raised.

0 marks:

No relevant content.

Indicative content

- closing the (ignition) switch causes a current to pass through the electromagnet
- the iron core (of the electromagnet) becomes magnetised
- the electromagnet / iron core attracts the (short side of the) iron arm
- the iron arm pushes the (starter motor) contacts (inside the electromagnetic switch) together
- the starter motor circuit is complete
- a current flows through the starter motor (which then turns)

4

[6]

2

- (a) move a (magnetic / plotting) compass around the wire

1

the changing direction of the compass needle shows a magnetic field has been produced

OR

sprinkle iron filings onto the card (1)

tapping the card will move the filings to show the magnetic field (pattern) (1)

1

(b) **Level 2 (3–4 marks):**

A detailed and coherent explanation is provided. The response makes logical links between clearly identified, relevant points that explain how the ignition circuit works.

Level 1 (1–2 marks):

Simple statements are made. The response may fail to make logical links between the points raised.

0 marks:

No relevant content

Indicative content

- closing the (ignition) switch causes a current to pass through the electromagnet
- the iron core (of the electromagnet) becomes magnetised
- the electromagnet / iron core attracts the (short side of the) iron arm
- the iron arm pushes the contacts (inside the electromagnetic switch) together
- the starter motor circuit is complete
- a current flows through the starter motor (which then turns)

4

[6]

3

(a) motor effect

1

(b) increase the strength of the magnet

or

increase the current

1

(c) $4.8 \times 10^{-4} = F \times 8 \times 10^{-2}$

1

$$F = 6 \times 10^{-3} \text{ (N)}$$

1

$$6 \times 10^{-3} = B \times 1.5 \times 5 \times 10^{-2}$$

1

$$B = \frac{6 \times 10^{-3}}{7.5 \times 10^{-2}}$$

1

$$B = 8 \times 10^{-2} \text{ or } 0.08$$

1

allow 8×10^{-2} or 0.08 with no working shown for 5 marks

a correct method with correct calculation using an incorrect value of F gains 3 marks

Tesla

accept T

1

do not accept t

[8]

4

(a) hydraulic (system)

1

(b) 15.40×10^2
or
1540

allow 1 mark for correct substitution, ie

$$8.75 \times 10^4 = \frac{F}{1.76 \times 10^{-2}}$$

or

$$87\,500 = \frac{F}{0.0176}$$

or

$$F = 8.75 \times 10^4 \times 1.76 \times 10^{-2}$$

or

$$F = 87\,500 \times 0.0176$$

2

(c) any **one** environmental **advantage**:

stating a converse statement is insufficient, or a disadvantage of the usual oil, ie the usual oil is non-renewable

plant oil is renewable

using plant oil will conserve (limited) supplies or extend lifetime of the usual / crude oil.

plant oil releases less carbon dioxide (when it is being produced / processed)

plant oil will add less carbon dioxide to the atmosphere (when it is being produced / processed, than the usual oil)

plant oil removes carbon dioxide from or adds oxygen to the air when it is growing
stating that plant oil is carbon neutral is insufficient

1

(d) (the current flowing through the coil) creates a magnetic field (around the coil)

1

(this magnetic field) interacts with the permanent magnetic field

or

current carrying conductor is in a (permanent) magnetic field

it must be clear which magnetic field is which

1

this produces a (resultant) force (and coil / cone moves)

1

when the direction of the current changes, the direction of the force changes to the opposite direction

accept for 2 marks the magnetic field of the coil interacts with the permanent magnetic field

1

[8]

5

(a) north (pole)

accept N

north (pole)

both needed for mark

1

(b) reverses

accept changes direction

1

(c) (i) first finger:
(direction of) (magnetic) field

1

second finger:
(direction of) (conventional) current

1

(ii) into (plane of the) paper

1

(iii) less current in wire

accept less current / voltage / more resistance / thinner wire

1

weaker field

allow weaker magnets / magnets further apart

*do **not** accept smaller magnets*

1

rotation of magnets (so) field is no longer perpendicular to wire

1

(d) (i) reverse one of the magnets

*do **not** accept there are no numbers on the scale*

1

(ii) systematic or zero error

accept all current values will be too big

accept it does not return to zero

accept it does not start at zero

1

[10]

6

(a) (i) 9000

an answer of 9 k(N) gains 1 mark

1

(ii) increase

*accept other comparative terms, eg give a bigger
affect / change is insufficient*

1

(iii) smaller

accept other comparative terms, eg less

1

(b) Q N M

all three in correct boxes

one statement in correct box gains 1 mark

2

(c) any **two** from:

- increase the current / p.d. (supplied to the coil)
*accept reduce the resistance of the coil **or** increase cross sectional
area of wire*
*accept more cells / batteries **or** turn up the power supply*
increase power is insufficient
- increase number of turns (on the coil)
- increase the area (of the coil)
accept increase the width of the coil
increase width / size is insufficient
- increase the (strength of the permanent) magnetic field
accept move the magnets closer to the coil
accept use stronger magnets
*do **not** accept use larger magnets*

2

(d) an economic

1

[8]

7

(a) (i) the greater the speed (of a centrifuge), the greater the force

answers must be comparative

accept velocity for speed

accept positive correlation between speed and force

speed and force are not proportional – treat as neutral

1

the smaller the radius, the greater the force (at a given speed)
allow (**G machine 1**) has / produces a greater force (than
G machine 2) at the same speed
must be comparative, eg a small radius produces a large force = 0
marks on own

1

as the speed increases the rate of change in force increases
accept force is proportional to the square of the speed
or
doubling speed, quadruples the force
accept any clearly correct conclusion

1

(ii) 12000 (N)

or

12 k(N)

1

(b) (i) the current (in the coil) creates a magnetic field (around the coil)
accept the coil is an electromagnet

1

so the magnetic field of the coil interacts with the (permanent) magnetic field of
the magnets (producing a force)

accept the two magnetic fields interact (producing a force)
if no marks scored an answer in terms of current is perpendicular to
the (permanent) magnetic field is worth max 1 mark

1

(ii) vertically downwards arrow on side A
one arrow insufficient

and

vertically upwards arrow on side C

1

(iii) the current is parallel to the magnetic field
allow the current and magnetic field are in the same direction
allow it / the wire is parallel to the magnetic field

1

(c) increase the current / p.d. (of the coil)
accept decrease resistance
accept voltage for p.d.
accept increase strength of magnetic field / electromagnet

1

(d) yes with suitable reason

or

no with suitable reason

eg

yes – *it has increased our knowledge*

yes – *It has led to more (rapid) developments / discoveries (in technology / materials / transport) accept specific examples*

no – *the money would have been better spent elsewhere on such things as hospitals (must quote where, other things not enough)*

no mark for just **yes** / **no**

reason must match yes / no

1

[10]

8

(a) a force

1

(b) any **two** from:

- more powerful magnet

do not allow 'bigger magnet'

- reduce the gap (between magnet and coil)

- increase the area of the coil

- more powerful cell

do not allow 'bigger cell'

accept battery for cell

accept add a cell

accept increase current / potential difference

- more turns (on the coil)

allow 'more coils on the coil'

do not allow 'bigger coil'

2

(c) reverse the (polarity) of the cell

allow 'turn the cell the other way round'

accept battery for cell

1

reverse the (polarity) of the magnet

allow 'turn the magnet the other way up'

1

[5]

9

(a) (i) current produces a magnetic field (around XY)

accept current (in XY) is perpendicular to the (permanent) magnetic field

1

(creating) a force (acting) on XY / wire / upwards
reference to Fleming's left hand rule is insufficient

1

(ii) motor (effect)

1

(iii) vibrate / move up and down

1

5 times a second

only scores if first mark point scores

allow for 1 mark only an answer 'changes direction 5 times a second'

1

(b) 0.005

*allow 1 mark for calculating moment of the weight as 0.04 (Ncm)
and*

allow 1 mark for correctly stating principle of moments

or

allow 2 marks for correct substitution

ie $F \times 8 = 2 \times 0.02$ or $F \times 8 = 0.04$

3

[8]

10

(a) (i) an electric motor

1

(ii) force

1

- (b) any **two** from:
- more powerful magnet
do not allow 'bigger magnet'
 - reduce the gap (between magnet and coil)
 - increase the area of the coil
 - more powerful cell
do not allow 'bigger cell'
accept battery for cell
accept add a cell
accept increase current / potential difference
 - more turns (on the coil)
allow 'more coils on the coil'
do not allow 'bigger coil'
- 2
- (c) reverse the (polarity) of the cell
allow 'turn the cell the other way round'
accept battery for cell
- 1
- reverse the (polarity) of the magnet
allow 'turn the magnet the other way up'
- 1

[6]

11

- (a) (i) an electrical conductor
- 1
- (ii) increase current
accept increase p.d. / voltage
or
use stronger magnets
accept move magnets closer
do not accept use larger magnets
- 1
- (iii) reverse the poles / ends (of the magnet)
either order
- 1
- reverse the connections (to the power supply)
- 1
- (b) (i) environmental
- 1

(ii) ethical

allow political (instability)

allow economic (migration)

1

[6]

12

(a) centre of the **X** midway between the poles

intention correct as judged by eye

example

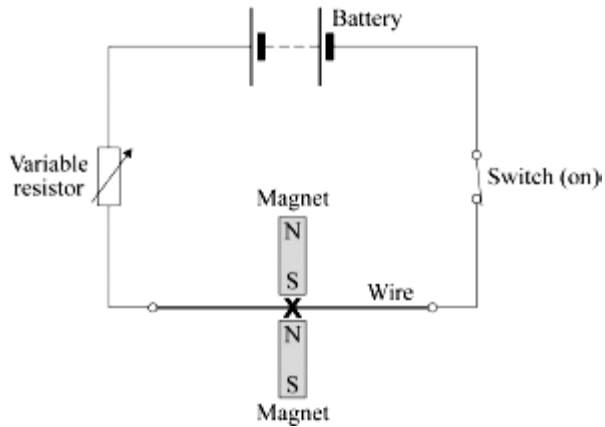

1

(b) move the poles further apart

accept turn for move

accept ends / magnets for poles

accept use weaker magnets

do not accept use smaller magnets

1

(c) (i) add more cells (to the battery)

do not accept 'use a bigger battery'

accept increase the potential difference / voltage

accept increase the current

or

reduce the resistance (of the variable resistor)

do not accept any changes to the magnets, to the wire or to their relative positions

1

- (ii) reverse (the polarity of) the battery
accept turn the battery / cells round
accept swap the connections to the battery
*do **not** accept any changes to the magnets, to the wire or to their relative positions*

1

[4]

13

- (a) motor (effect)

1

- (b) (i) wire kicks further (forward)
accept moves for kicks
accept moves more
accept 'force (on the wire) increased'

1

- (ii) wire kicks back(wards) / into (the space in) the (horseshoe) magnet
accept moves for kicks
accept 'direction of force reversed'

1

[3]

14

- (a) electric drill, electric fan, electric food mixer and electric screwdriver
all four ticked and no others (2)
***either** all four of these ticked and only one other (1)*
***or** any three of these ticked and none/one/two of the others (1)*

2

- (b) (i) reverse (the direction of the) current (1)
***or** reverse the connections (to the battery)*
 reverse (the direction of the) magnetic field (1)
***or** reverse the (magnetic) poles /ends*
*do **not** credit 'swap the magnets (around)'*

2

(ii) any **two** from:

- increase the strength of the magnet(s)/(magnetic) field
do not credit 'use a bigger magnet'
- increase the current
allow 'increase the voltage/p.d.'
allow add cells/batteries
allow increase the (electrical) energy
allow increase the power supply
allow 'decrease the resistance'
allow 'increase charge'
allow 'increase the electricity'
do not credit 'use a bigger battery'
- reduce the gap (between coil/armature and poles/magnets)
allow increase the (number of) coils
- increase the turns (on the coil/armature)
do not credit 'use a bigger coil'

2

[6]

15

(a) increase the current (1)

credit increase the p.d./voltage
credit reduce the resistance
credit have thicker wiring
credit add extra / more cells

1

increase the magnetic field (strength) (1)

credit 'have stronger magnet(s)'
do not credit 'bigger magnets' either order

1

(b) **either** reverse polarity

or connect the battery the other way round

1

either reverse direction of the magnetic field

or put the magnet the other way round / reverse the magnet

do not give any credit to a response in which both are done at the same time

either order

1

- (c) **either**
conductor parallel to the magnetic field
or lines of magnetic force and path of electricity do not cross

1

[5]

16

- (a) step-down (transformer)

1

- (b) alternating current

*accept minor misspellings but
do **not** credit 'alternative current'*

1

- (c) (i)(ii) magnet

attracts

upwards

*correct order essential
accept 'up'*

3

[5]

17

- (i) away from magnet

*arrow should be perpendicular to field lines and current as judged
by eye*

1

- (ii) current in wire creates magnetic field around wire

1

two fields interact **or** combine giving a resultant force (on the wire)

1

[3]

18

- (a) (i) it moves or experiences a force horizontally to the right
for 1 mark

1

- (ii) A – moves in opposite direction or force reversed e.c.f.
B – faster movement or larger force
(**not** move further)

for 1 mark each

2

- (b) turns clockwise
oscillates/reverses
comes to rest facing field/at 90° to field/vertically

for 1 mark each

3

- (c) number of turns or linear number density of turns current core

for 1 mark each

3

[9]