

AQA GCSE Physics Required Practicals

An independent variable is the variable that is changed or controlled in a scientific experiment to test the effects on the dependent variable. A dependent variable is the variable being tested and measured in a scientific experiment. The dependent variable is 'dependent' on the independent variable. Control variables are all the other variables that could affect the dependent variable. They are kept the same during the experiment to give a fair test of the independent variable.

		Independent	Dependent	Control
		What is changed	What is measured	What is kept the same
Paper 1	Specific Heat Capacity	electrical energy input	temperature rise	mass of block thickness of insulation
	Thermal Insulation	type of insulation	temperature drop	volume of water start temperature
	Resistance 1	length of wire	electrical resistance (V and I as $R=V/I$)	thickness of wire material of wire
	Resistance 2	series or parallel	electrical resistance	value of resistors
	I-V characteristics Bulb, Resistor, Diode	potential difference	current	component rest of circuit
	Density	object or material	mass and volume density = m/v	gravity (stays the same on its own)
Paper 2	Force and Extension	force	extension	the spring (gravity)
	Acceleration 1	force	acceleration	mass
	Acceleration 2	mass	acceleration	force
	Waves (on a string)	frequency	wavelength	tension in string mass of string
	Light	angle of incidence and block material	angle of refraction angle of reflection	colour of light shape of block
	Radiation and Absorption	colour and texture of surface	intensity of emitted IR radiation	surface temperature distance from surface

Repeatable: When a measurement is repeated there is little variation in the measured value.

Reproducible: When an experiment is done by someone else the findings are the same.

Anomaly: The result of a measurement that does not fit the pattern in the other results.

Resolution: The size of the divisions on a measuring instrument.

Range: The minimum to maximum values tested or measured.

Paper 1

Specific Heat Capacity

- metal block with two holes
- thermometer
- heater
- power supply
- insulation to wrap around the blocks
- joulemeter
- balance to determine the mass of the blocks
- heatproof mat

1. Measure the mass of the metal block with the balance
2. Zero the joule meter
3. Take the temperature of the block
4. Turn on the power supply
5. Heat by only around 10°C to reduce heat losses
6. Turn off the supply and record the highest temperature reached
7. Record the electrical energy input from the joulemeter

$$\text{specific heat capacity} = \frac{\text{energy transferred}}{\text{mass} \times \text{temperature rise}}$$

Safety:
Care with hot heater

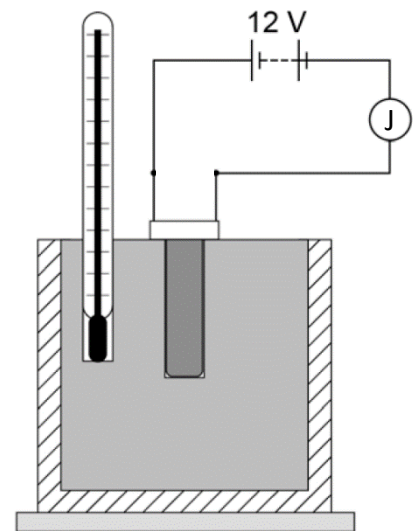

Thermal Insulation

- boiling tubes and rack
- thermometer
- stopwatch
- kettle
- thermometers (in bungs)
- sheets of insulating material



1. Cover boiling tubes in different insulations
2. Add boiling water to tubes
3. Place thermometers in water
4. Make sure top is sealed to prevent evaporation
5. Wait for highest temperature reached
6. Record temperature as it falls at regular time intervals
7. Repeat with different insulating materials
8. Plot graph of temperature against time

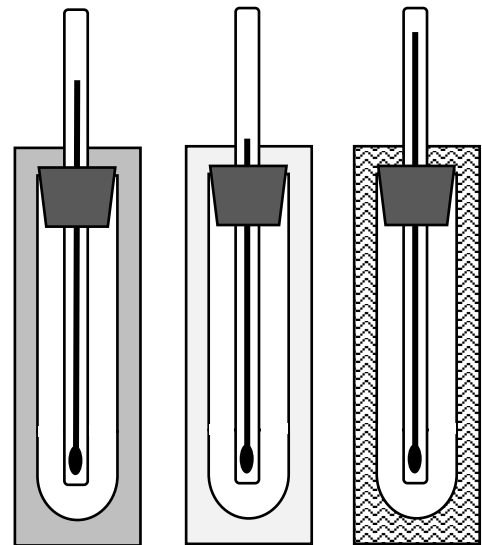

Safety:
Care with hot water

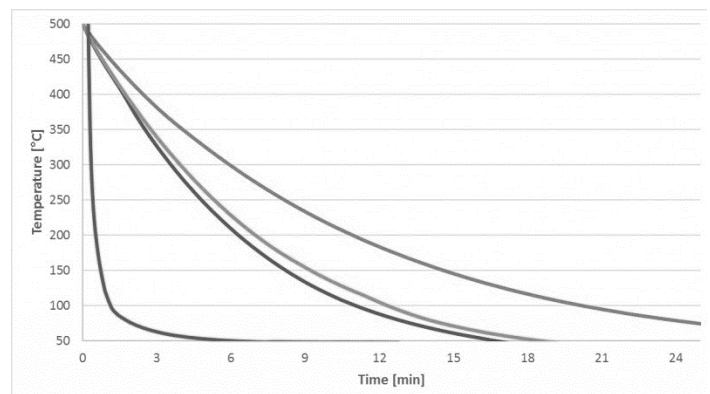

Electrical Resistance

Activity 1

- resistance wire on meter rule
- ammeter
- voltmeter
- power supply
- leads and crocodile clips

Safety:
Care with hot wire

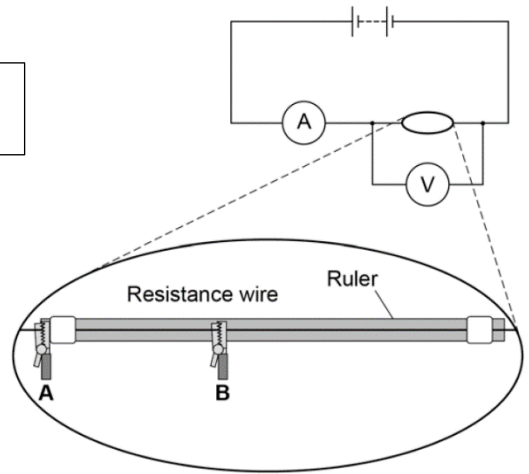

1. Connect up the circuit as in the diagram
2. The resistance wire is connected at points A and B
3. Keep A and B greater than 10cm to prevent the wire getting too hot
4. Measure the distance between A and B
5. Record the current and potential difference
6. Calculate the resistance using $R=V/I$
7. Increase distance between A and B and repeat
8. Plot a graph of length of wire against resistance

Activity 2

- a battery or suitable power supply
- a switch
- ammeter
- voltmeter
- crocodile clips
- two identical resistors
- connecting leads

1. Connect up the circuit as in the first diagram but with a single resistor
2. Record the current and potential difference
3. Calculate the resistance using $R=V/I$
4. Repeat for the second resistor
5. Connect up the first circuit with the resistors in series
6. Record the current and potential difference
7. Calculate the resistance using $R=V/I$
8. Connect up the second circuit with the resistors in parallel
9. Record the current and potential difference
10. Calculate the resistance using $R=V/I$

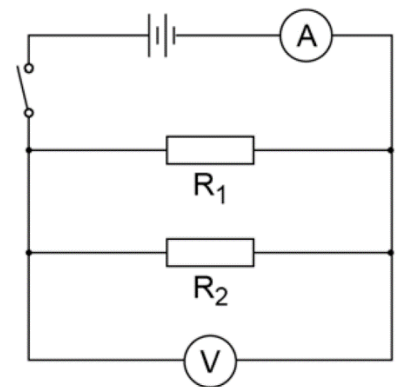
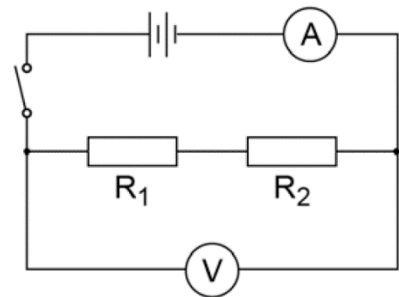

Sample results

Resistance in Ohms			
Resistor 1	Resistor 2	Series	Parallel
10	10	20	5

I-V Characteristics of a Filament Lamp, a Resistor and a Diode

- Power Supply or Battery Pack
- Leads
- Variable resistor (rheostat)
- Ammeter and Milliammeter (could be multimeter)
- Voltmeter (could be multimeter)
- Filament Lamp
- Resistor
- Diode and extra resistor P

Safety:
Care with hot component

1. Connect up the circuits as in the circuit diagrams
2. Use the variable resistor to alter the p.d. across the component
3. Record the p.d. and current.
4. Repeat with the component reversed for negative V and I values
5. For the diode add the resistor P to prevent damage to the diode
6. For the diode use a milliammeter or the mA setting on a multimeter
7. For each component plot a graph of V against I

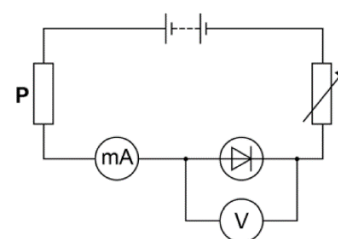
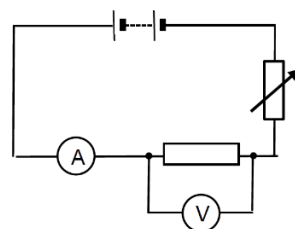
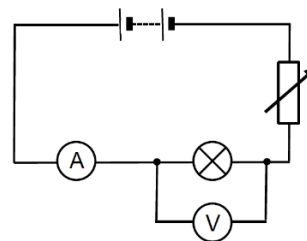

Density

Activity 1 A regularly shaped object

- 30 cm ruler in mm
- digital balance
- a selection of regularly shaped objects

1. Measure the length, width and height of the object using the ruler
2. Calculate the volume of the object using - volume = length x width x height
3. Measure the mass of the object using the balance
4. Calculate the density using - density = mass / volume
5. Repeat for the other regular objects

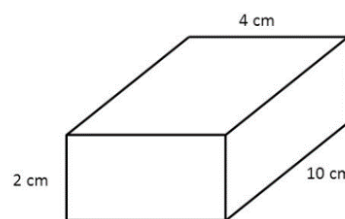

Volume of this rectangular solid =
 $4 \text{ cm} \times 2 \text{ cm} \times 10 \text{ cm} = 80 \text{ cm}^3$

Regular shaped object	Length in cm	Width in cm	Height in cm	Volume in cm^3	Mass in g	Density in g/cm^3

Activity 2 An irregularly shaped object

- a digital balance
- a displacement (eureka) can
- measuring cylinder
- a beaker of water and an extra empty beaker
- a selection of irregularly shaped objects

1. Fill eureka with water and allow excess water to drain
2. Place empty measuring cylinder under spout of can
3. Submerge object in can and collect displaced water
4. Record the volume of the displaced water which is the volume of the object
5. Measure the mass of the object using the balance
6. Calculate the density using - density = mass / volume
7. Repeat for the other irregular objects

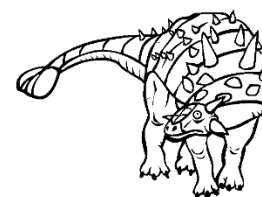
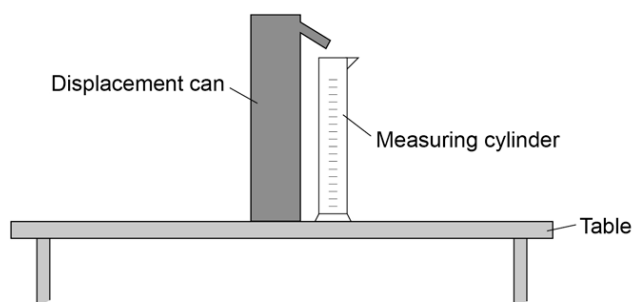

Activity 3 A liquid

Measure the volume of the liquid using a measuring cylinder and the mass by pouring it into a beaker on an electronic balance that has been zeroed. The density is calculated in the same way as above.

Paper 2

Force and Extension of a Spring

Safety:
Eye protection

- spring
- metre ruler
- splint and tape to act as a pointer
- 10 N weights (or 0.1 kg masses and multiply by 9.8 to get weight)
- clamp stand
- clamps and bosses
- Weight or G-clamp to prevent the apparatus tipping over
- safety goggles in case the spring flies off

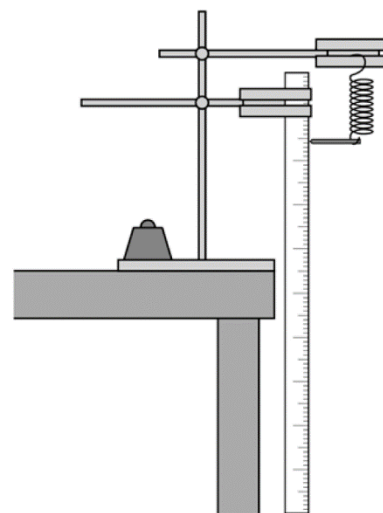

1. Set the apparatus up as in the diagram
2. Record the length of the unextended spring
3. Add a weight to the spring – the weight is the force on the spring
4. Record the new length of the spring
5. Add another mass and repeat
6. Subtract the original length of the spring from the lengths to calculate the extension
7. Plot a graph of force against extension.
The gradient of the graph is the spring constant.

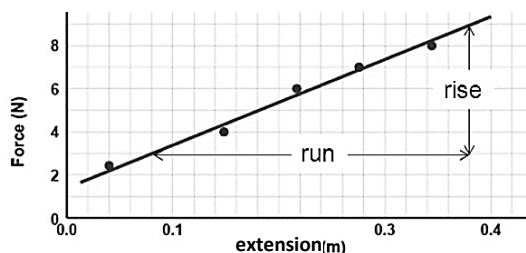

$$\text{Slope} = \frac{\text{rise}}{\text{run}} = \frac{9 \text{ N} - 3 \text{ N}}{0.38 \text{ m} - 0.08 \text{ m}} = 20 \text{ N/m}$$

Acceleration

- trolley
- metre ruler
- pulley
- string
- stack of masses
- electronic balance
- light-gates and datalogger + laptop with timing software

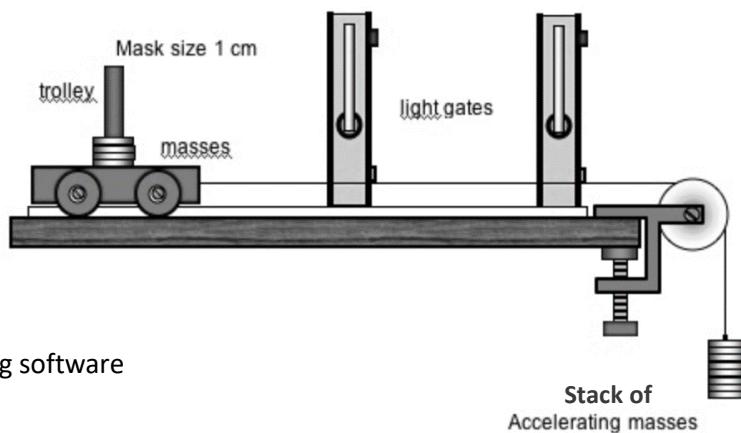

1. Set up the equipment as in the diagram
2. Set the software to measure acceleration from gate A to B
3. Measure and enter the length of the card mask that cuts the light beams into the computer
4. Measure and enter the distance between the light gates into the computer
5. Measure the mass of the all the masses and trolley together
6. Start with one accelerating mass and the rest on the trolley
7. Let the mass accelerate the trolley and record the acceleration
8. Calculate the accelerating force by multiplying the accelerating mass by 9.8 N/kg
9. Move a mass from the trolley to the stack of masses (this keeps the total mass constant) and repeat.
10. Repeat until all the masses are on the stack
11. Plot a graph of force against acceleration.

The experiment can be repeated but this time keep the accelerating force constant by using the same number of masses on the stack. The mass being accelerated is then changed by adding masses to the trolley. Then plot a graph of acceleration against mass.

Safety:
Don't drop masses on foot

Waves

Activity 1 Observing water waves in a ripple tank

- ripple tank plus accessories
- low-voltage power supply
- lamp
- metre ruler

Safety:
Care with electricity + water

1. Set up the equipment as in the diagram
2. Put about 5mm depth of water in the ripple tank
3. Measure and record the depth of water using a meter rule
4. Turn on the motor
5. Measure the time for ten waves to pass
6. Divide the time by 10 to get the wave period
7. Calculate the frequency using - **frequency = 1/period**
8. Measure the length of 6 to 8 waves and divide to get the wavelength.
9. Calculate the wave speed using - **wave speed = frequency x wavelength**
10. Add more water to the tank and repeat
11. Plot a graph of wave speed against depth of water

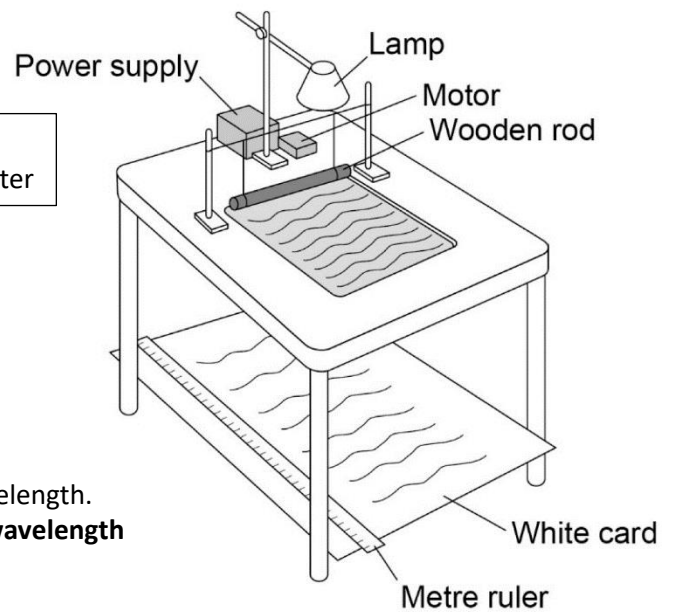

Activity 2 Observing waves in a solid

- vibration generator
- signal generator
- string
- set of masses and hanger
- wooden bridge
- a pulley on a clamp

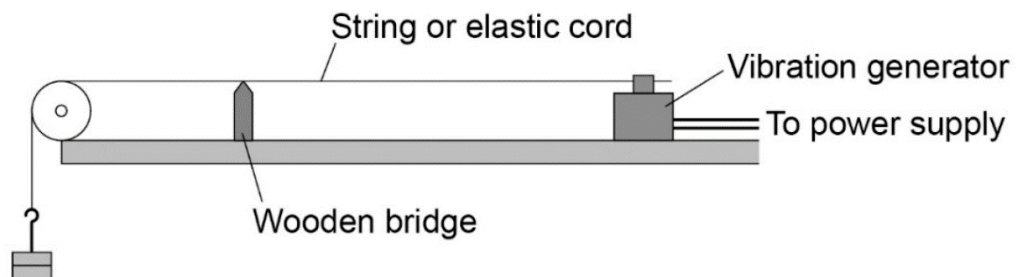

1. Switch on the vibration generator. The string should start to vibrate.
2. To see a clear wave pattern, adjust the frequency on the signal generator to get a standing wave pattern.
3. The waves should look like they are not moving.
4. Use a metre ruler to measure across as many half wavelengths as possible (a half wavelength is one loop).
5. Then divide the total length by the number of half waves. Multiplying this by two will give the wavelength.
6. The frequency of the wave is the frequency of the signal generator.
7. Calculate the speed of the wave using the equation - **wave speed = frequency x wavelength**
8. Repeat with different standing wave patterns.

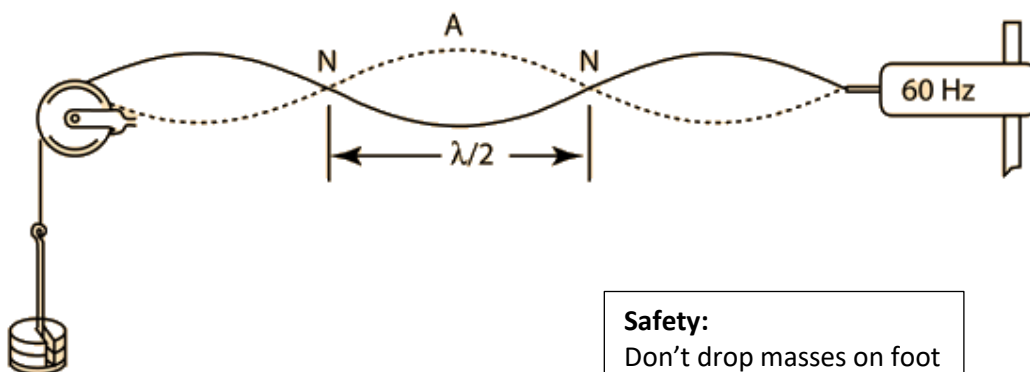

Safety:
Don't drop masses on foot

Light

Safety:
Care with hot ray box

- ray box
- power supply
- a slit for ray box to make a narrow ray
- glass block + Perspex block
- 30 cm ruler
- protractor
- sheets of plain A3 paper

1. Place glass block on the paper and draw around it.
2. Use protractor to draw a normal line to the block
3. Aim a ray of light at an angle to the normal where it meets the block
4. Mark the path of the rays using crosses
5. Include both the refracted and reflected rays. Then turn off ray box.
6. Remove the block and use the crosses as a guide to mark the path of the rays.
7. Use a protractor to measure and record:
 - a) the angle of incidence
 - b) the angle of reflection
 - c) the angle of refraction
8. Repeat with a block made from a different material keeping the angle in incidence the same.

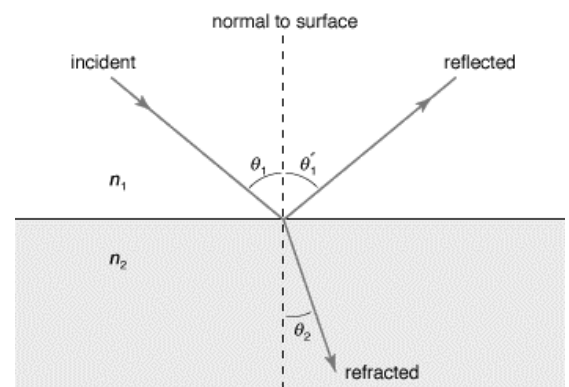
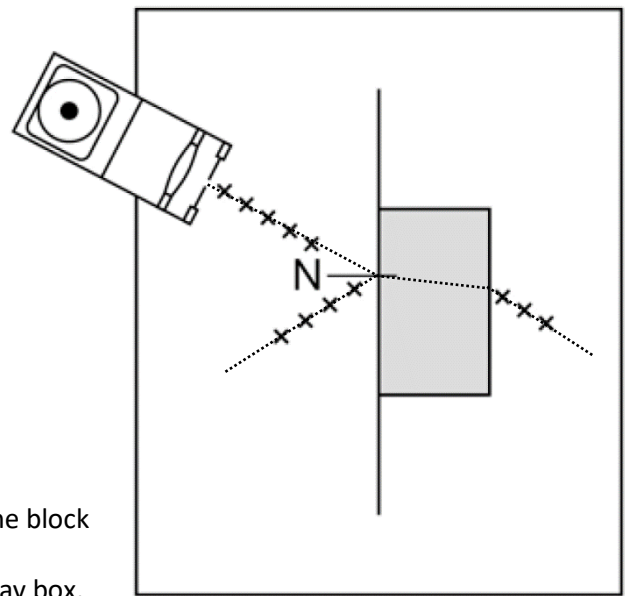

Radiation and Absorption

- Leslie cube
- kettle
- infrared detector or thermal imaging camera
- heat-proof mat

1. Put the Leslie cube onto the heat-proof mat
2. Fill the cube with very hot water and put the lid on the cube
3. Use the detector or camera to measure the amount of infrared radiated from each surface
4. Make sure that the detector is the same distance from each surface.
5. Draw a chart to show the amount of infrared radiated by each type of surface

Safety:
Care with hot water

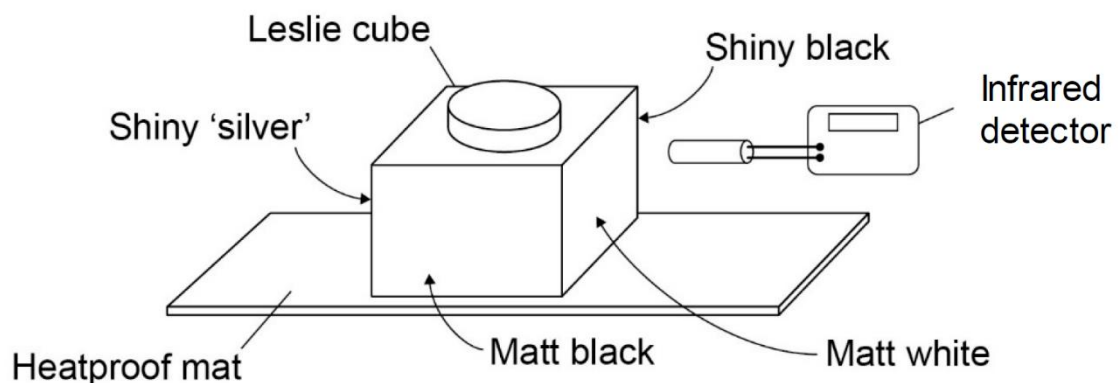

Make your own summary notes for each practical based on this template

Independent Variable(s) The one you vary.	Dependent Variable(s) The one you measure.	Control Variables Kept the same for a fair test.

Method	Step 1	Diagram of set up.
	Step 2	
	Step 3	
	Step 4	
	Step 5	
	Step 6	
	Step 7	

Measurement	Instrument Used	How Instrument is used / How to minimise errors

Equations / Calculations used to process results	Safety Precautions