



Oxford Cambridge and RSA

A Level Physics B (Advancing physics)

H557/01 Fundamentals of Physics

Monday 4 June 2018 – Afternoon

Time allowed: 2 hours 15 minutes



You must have:

- The Data, Formulae and Relationships Booklet (sent with general stationery)

You may use:

- a scientific or graphical calculator
- a ruler (cm/mm)



First name										
Last name										
Centre number						Candidate number				

INSTRUCTIONS

- Use black ink. You may use an HB pencil for graphs and diagrams.
- Complete the boxes above with your name, centre number and candidate number.
- Answer **all** the questions.
- Write your answer to each question in the space provided. If additional space is required, use the lined page(s) at the end of this booklet. The question number(s) must be clearly shown.
- Do **not** write in the barcodes.

INFORMATION

- The total mark for this paper is **110**.
- The marks for each question are shown in brackets [].
- Quality of extended responses will be assessed in questions marked with an asterisk (*).
- This document consists of **36** pages.

2
SECTION A

You should spend a maximum of 40 minutes on this section.

Write your answer for each question in the box provided.

Answer **all** the questions.

- 1** Which expression gives a quantity that can be expressed in joules?
- A** $F v$ where F is the force causing a body to move and v is its speed
 - B** $I^2 R$ where I is the current flowing through a resistance of value R
 - C** $m v$ where m is the mass of a body moving with velocity v
 - D** $V I t$ where V is the potential difference across a conductor and I is the current in it for time t .

Your answer

[1]

- 2** Which of these ages is estimated correctly?
- A** The Earth is about 4 billion years old.
 - B** The Sun is about 14 billion years old.
 - C** The Milky Way Galaxy is about 20 billion years old.
 - D** The Universe is about 20 billion years old.

Your answer

[1]

- 3** How many bits are required to code for 1300 different levels?
- A** 3
 - B** 4
 - C** 10
 - D** 11

Your answer

[1]

- 4 An image sent from Pluto to Earth is 1024×1024 pixels. Each pixel is coded by 12 bits. The data is transferred at a rate of 200 bytes per second.

How long does it take to transmit the data?

- A 11 minutes
- B 87 minutes
- C 131 minutes
- D 1049 minutes

Your answer

[1]

- 5 A boat travels eastwards with a velocity of 12 ms^{-1} . A current from the south pushes the boat northwards at a velocity of 5 ms^{-1} .

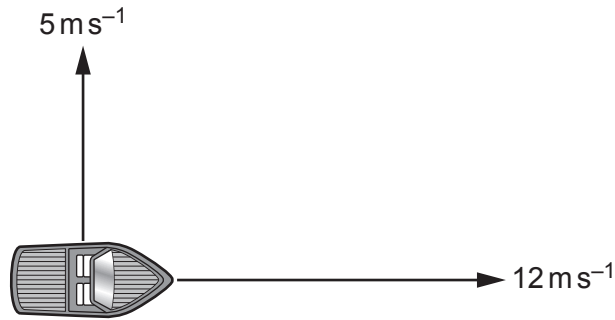

What is the magnitude of the resultant velocity of the boat?

- A 7 ms^{-1}
- B 13 ms^{-1}
- C 17 ms^{-1}
- D 169 ms^{-1}

Your answer

[1]

- 6 A weight of 20 N is suspended from a steel wire.

What is the extension of the wire?

Data: original length of wire = 2.5 m
 cross-sectional area of wire = $7.0 \times 10^{-8} \text{ m}^2$
 Young Modulus of the wire material = $2.1 \times 10^{11} \text{ Pa}$

- A 0.0030 m
 B 0.0034 m
 C 0.030 m
 D 0.034 m

Your answer

[1]

- 7 These two circuits use identical components.
 The cells have zero internal resistance.

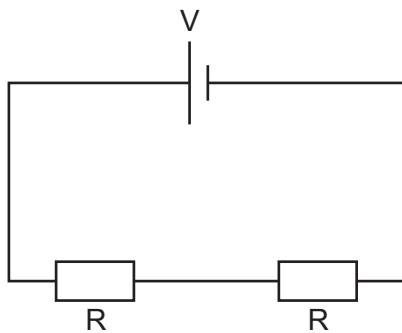

circuit 1

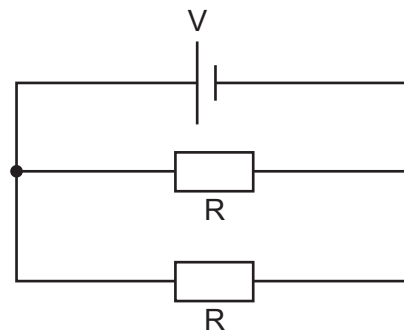

circuit 2

What is the ratio $\frac{\text{power dissipated in circuit 1}}{\text{power dissipated in circuit 2}}$?

- A $\frac{1}{4}$
 B $\frac{1}{2}$
 C 2
 D 4

Your answer

[1]

8 Which combination of resistors gives the **lowest** total resistance?

A

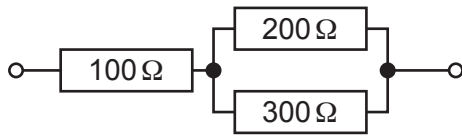

B

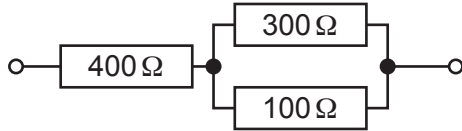

C

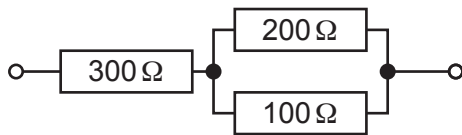

D

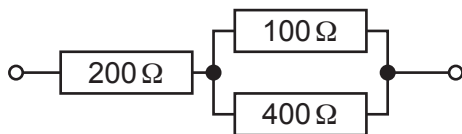

Your answer

[1]

- 9 The graph shows the displacement of a body which is oscillating periodically with time period T .

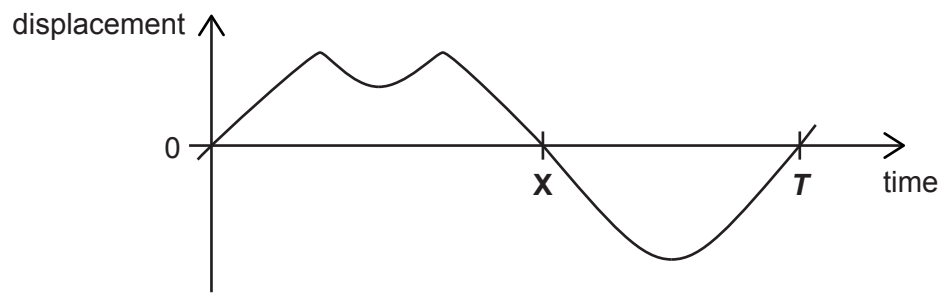

Which statement is correct?

- A The acceleration is zero at time **X**.
- B The body is performing simple harmonic motion.
- C In each cycle the velocity is zero three times.
- D The body changes direction at **X**.

Your answer

[1]

- 10 The spring in this diagram has a spring constant of 20 N m^{-1} .
The mass is pulled away from the fixed point. The spring stretches by 2.5 cm .
The mass is then released.

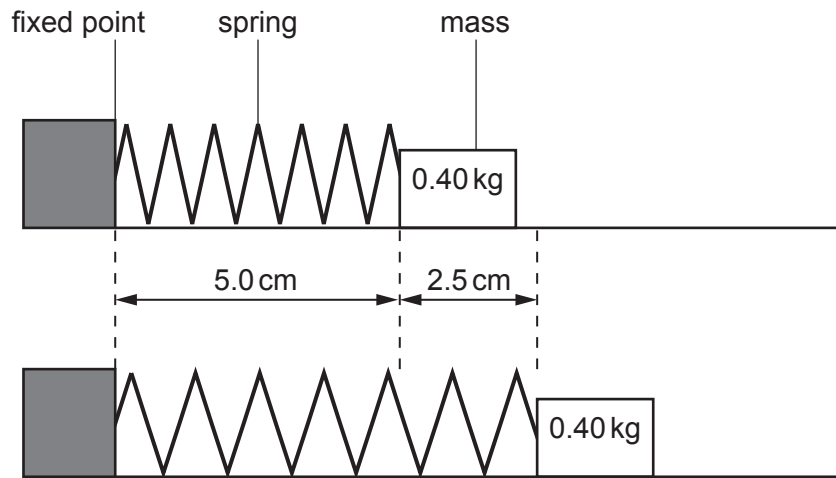

What is the maximum speed reached by the mass?

- A 0.18 ms^{-1}
B 0.53 ms^{-1}
C 1.25 ms^{-1}
D 3.75 ms^{-1}

Your answer

[1]

- 11 An electron is travelling at a speed of $3.1 \times 10^5 \text{ ms}^{-1}$.

What is its kinetic energy in electronvolts?

- A $4.4 \times 10^{-20} \text{ eV}$
B $8.8 \times 10^{-7} \text{ eV}$
C 0.27 eV
D 500 eV

Your answer

[1]

12 The diagram shows the beta energy spectrum for emissions from a radioactive isotope.

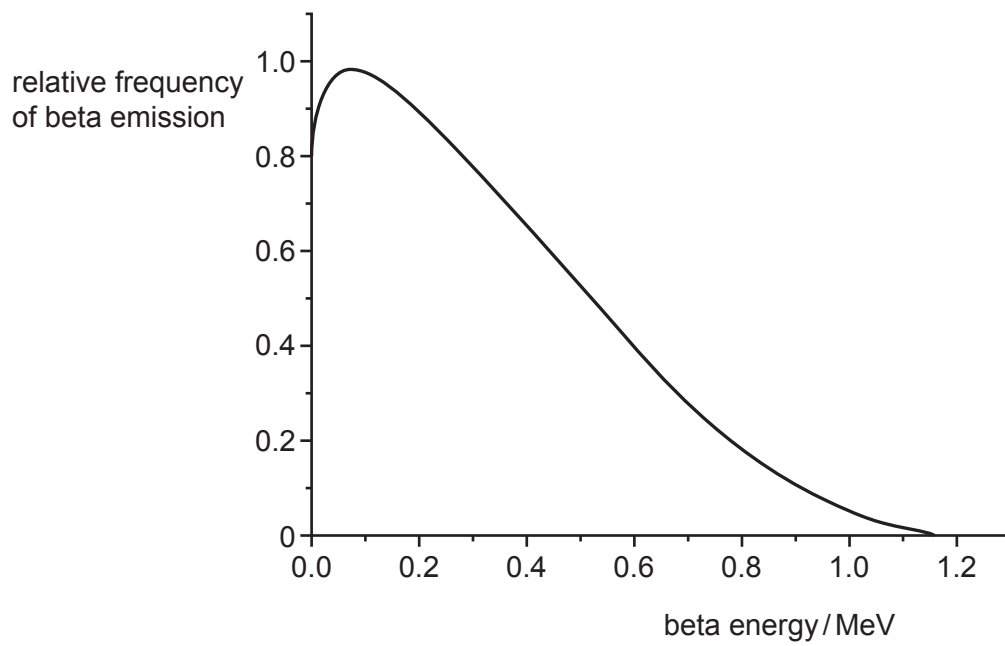

Which statement is correct?

- A The maximum energy of beta emissions is about 0.1 MeV.
- B More than half the beta particles are emitted with less than half the maximum energy.
- C The “missing energy” in beta emissions is taken by the recoiling nucleus.
- D The most frequent energy of beta emission is about 1.16 MeV.

Your answer

[1]

The following information is for use in questions 13 and 14.

An uncharged capacitor and a resistor are connected in this circuit.

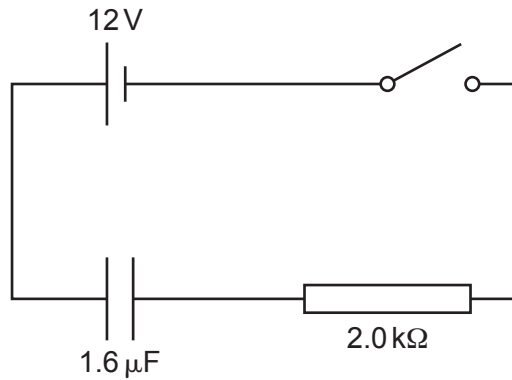

	current / mA	p.d. across the capacitor / V	p.d. across the resistor / V
A	0	12	0
B	2	8	4
C	3	6	6
D	6	0	12

- 13 Which set of values **A** to **D** above, most closely represents the situation immediately after the switch is closed?

Your answer

[1]

- 14 Which set of values **A** to **D** above, most closely represents the situation 3 seconds after the switch is closed?

Your answer

[1]

- 15 A liquid flows through a tube containing an electrical heater with a constant voltage. At a steady state of flow, the liquid leaves the tube at temperature $\Delta\theta$ higher than the liquid entering.

Which change will increase $\Delta\theta$ with no other changes?

- A Increasing the flow rate of the liquid.
- B Changing the liquid to one with a higher specific heat capacity.
- C Using a heating element of lower resistance.
- D Decreasing the supply voltage.

Your answer

[1]

- 16 A thermistor is used in a potential divider circuit.

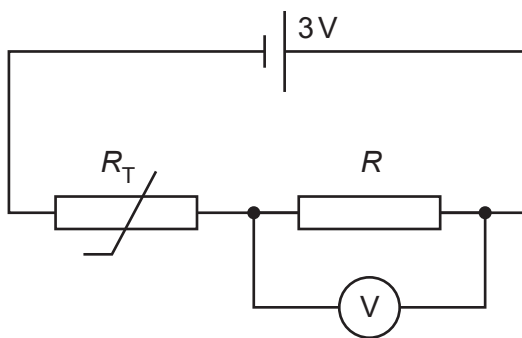

thermistor resistance $R_T / k\Omega$

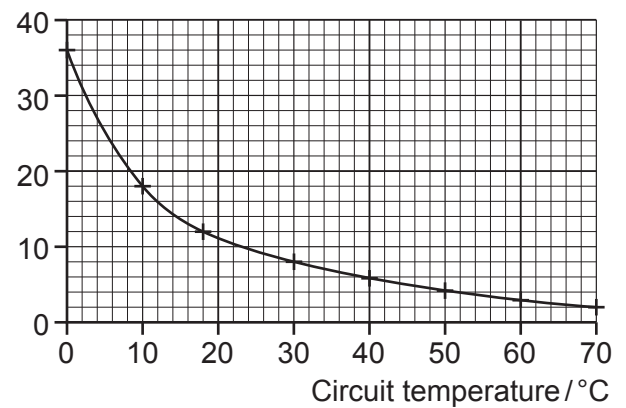

When the circuit temperature is 10°C the reading on the voltmeter is 1.0V .
What is the resistance of the resistor R ?

- A $6\text{ k}\Omega$
- B $9\text{ k}\Omega$
- C $18\text{ k}\Omega$
- D $36\text{ k}\Omega$

Your answer

[1]

The following information is for use in questions 17 and 18.

A transformer runs a 36.0W lamp from a 24.0V a.c. supply.

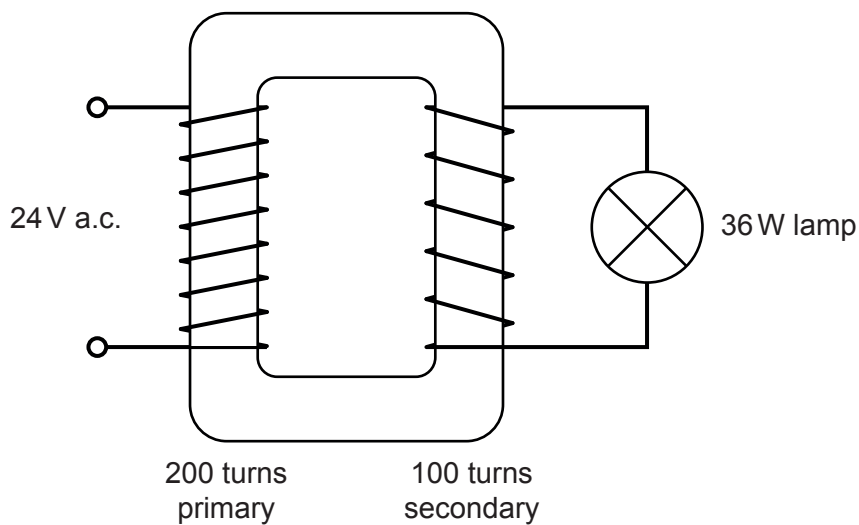

17 What is the current in the secondary coil?

- A 1.5A
- B 3.0A
- C 4.0A
- D 6.0A

Your answer

[1]

18 What is the best estimate for the rate of change of flux in the transformer core?

- A 0.12 Wb s^{-1}
- B $0.12 \text{ T m}^{-2} \text{ s}^{-1}$
- C 12 Wb s^{-1}
- D $12 \text{ T m}^{-2} \text{ s}^{-1}$

Your answer

[1]

- 19 An α particle approaches an atomic nucleus and is scattered through angle θ . The path of the particle is offset as shown.

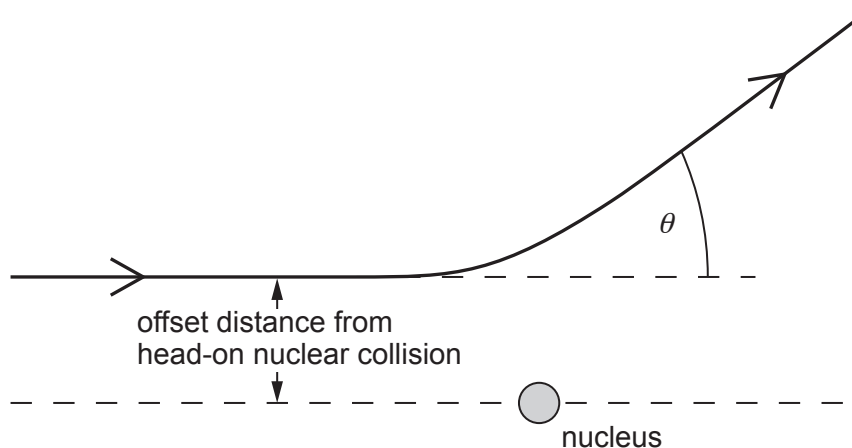

Which change on its own would cause the scattering angle θ to increase?

- A Use an α particle with higher kinetic energy.
- B Have a smaller offset distance for the initial trajectory.
- C Use a target nucleus with a smaller charge.
- D Use a target nucleus with a smaller mass.

Your answer

[1]

The following information is for use in questions 20 and 21.

A particle of charge q and mass m travels in a vacuum in a region of constant magnetic flux density B .

It moves at a constant speed v in a circle of radius r .

20 Which expression gives the time for the particle to complete one circle of its motion?

A $\frac{2\pi m}{Bqr}$

B $\frac{2\pi mr}{Bq}$

C $\frac{2\pi m}{Bq}$

D $\frac{Bq}{2\pi m}$

Your answer

[1]

21 A proton and an α particle, with the same velocity, enter the region of constant magnetic flux density.

What is the ratio of the radii of their paths, $\frac{r_{\alpha}}{r_{proton}}$?

A $\frac{1}{4}$

B $\frac{1}{2}$

C 2

D 4

Your answer

[1]

22 This table shows the half-lives of three radioactive isotopes.

Isotope	$^{60}\text{cobalt}$	$^{192}\text{iridium}$	$^{210}\text{thallium}$
Half-life	5.3 years	74 days	1.8 minutes

Which statement can be deduced from the information given?

- A The decay constant of thallium is smaller than that of iridium.
- B Because of the difference in half-lives, the energy of the particles emitted from cobalt must be less than the energy of the particles emitted by thallium.
- C The most active source will be thallium.
- D If the number of atoms in the cobalt and iridium sources is initially equal, then the iridium source will have the greater initial activity.

Your answer

[1]

23 The graph shows neutron number N plotted against proton number Z for stable nuclei.

N = neutron number

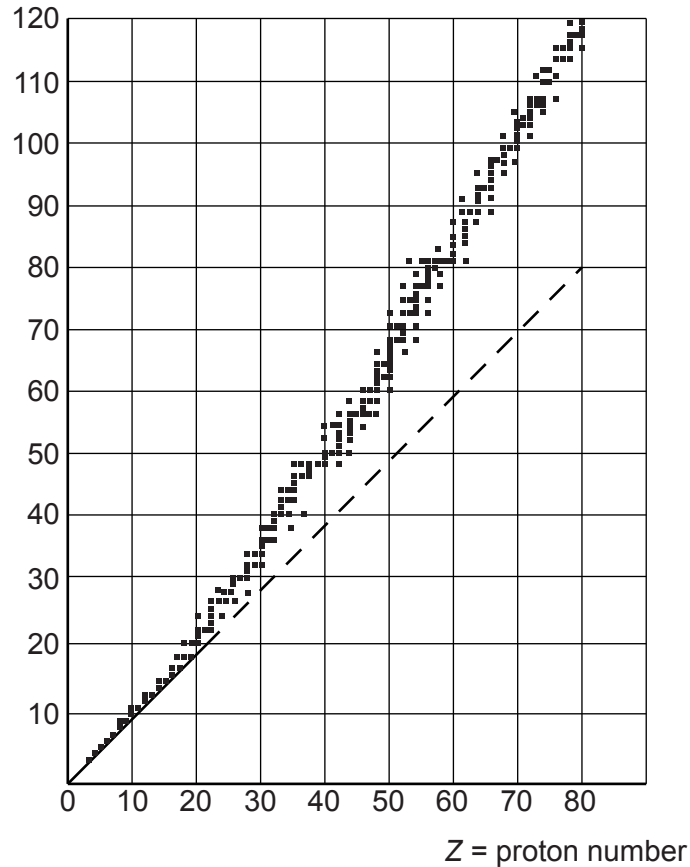

Which statement about stable nuclei is correct?

- A For elements up to about $Z = 50$ $N \approx Z$.
- B Elements with $Z \approx 80$ have more protons than neutrons.
- C Greater $\frac{N}{Z}$ ratio is needed to hold larger nuclei together, because only neutrons take part in the strong nuclear force of attraction to balance electrostatic repulsion.
- D Greater $\frac{N}{Z}$ ratio is needed to hold larger nuclei together because only nearest neighbour nucleons take part in the strong nuclear force of attraction to balance electrostatic repulsion.

Your answer

[1]

- 24 A ball is kicked from horizontal ground at a velocity of 15 m s^{-1} at an angle of 20° to the horizontal.

How long will the ball remain in the air before hitting the ground?
Ignore any effects of air resistance.

- A 0.5s
B 1.0s
C 1.4s
D 2.9s

Your answer

[1]

- 25 The diagram shows two boats **P** and **Q** sailing at constant velocity towards the finish line.

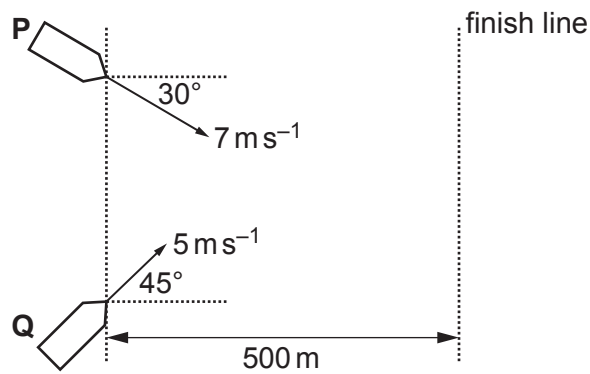

Which statement is correct?

- A Boat **P** wins by 1.4s.
B Boat **Q** wins by 29s.
C Boat **P** wins by 59s.
D Boat **Q** wins by 198s.

Your answer

[1]

The following information is for use in questions 26, 27 and 28.

Two stars of mass M and $4M$ are a distance d apart.
They orbit around their common centre of mass.

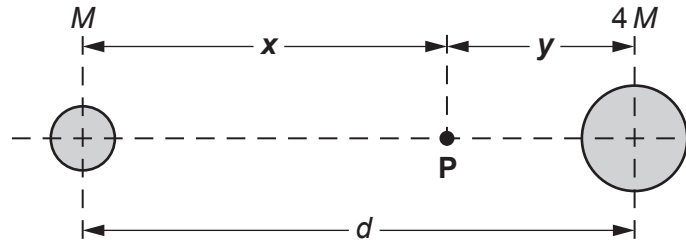

The point P , on the line between the centres of the stars, divides the distance d in the ratio $x : y$ as shown.

26 If P is the gravitational neutral point between the stars, which ratio is correct for $x : y$?

- A 1 : 4 B 1 : 2 C 2 : 1 D 4 : 1

Your answer

[1]

27 If P is the centre of mass of the two stars, which ratio is correct for $x : y$?

- A 1 : 4 B 1 : 2 C 2 : 1 D 4 : 1

Your answer

[1]

28 If P is the point where the gravitational potentials of the two stars are equal, which ratio is correct for $x : y$?

- A 1 : 4 B 1 : 2 C 2 : 1 D 4 : 1

Your answer

[1]

- 29 The electric potential at a distance r from a positive point charge Q is 450 V. The potential increases to 500 V when the distance from the point charge decreases by 1.5 m.

What is the value of r ?

- A 1.5 m
- B 7.9 m
- C 15 m
- D 29 m

Your answer

[1]

- 30 The relativistic factor $\gamma = \frac{1}{\sqrt{1 - \frac{v^2}{c^2}}}$

Which statement about this factor is correct?

- A At the speed of sound γ is close to zero.
- B $\gamma \rightarrow 1$ as $v \rightarrow c$.
- C γ predicts the time dilation factor so that moving clocks run slower as $v \rightarrow c$.
- D γ^2 is the factor by which the total energy of a moving particle is greater than its rest energy.

Your answer

[1]

19
SECTION B

Answer **all** the questions.

31 The lens in a digital clock projects the time onto a wall 1.5m away as shown in Fig. 31.

The digital display is 0.030m from the lens.

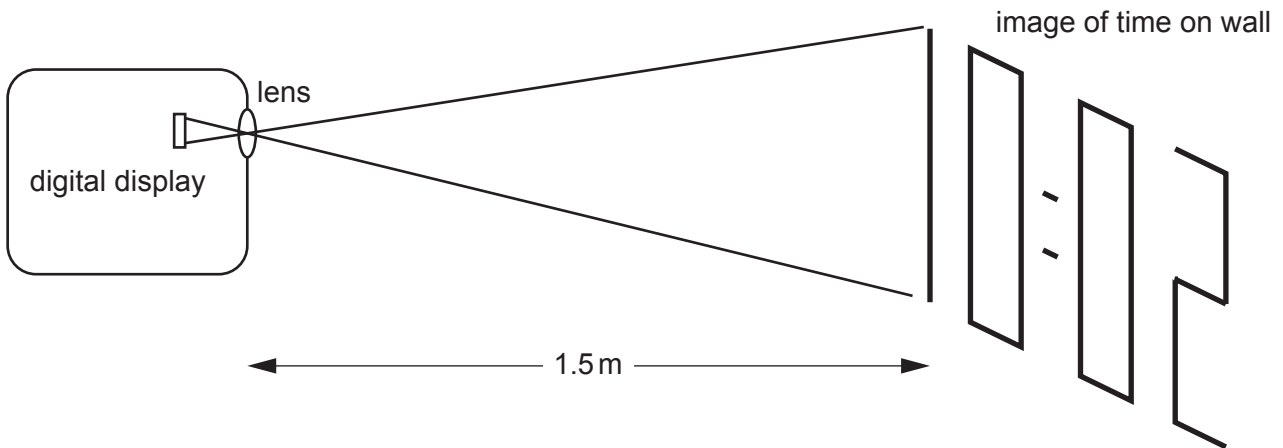

Fig. 31

(a) Calculate the power of the lens.

power of the lens = D [3]

(b) State the magnification of the lens in this example.

magnification = [1]

32 A video file is downloaded at a rate of 24 Mbits⁻¹.
The video file is 1.2 Gbytes in size.

(a) Show that the time taken for the file to download is greater than 6 minutes.

[2]

(b) The video file contains a soundtrack sampled at 16.0 kHz.
State and explain the highest frequency of sound that can be recorded on the soundtrack.

highest frequency kHz

.....
..... [2]

33 The radioactive isotope ²¹⁰₈₃Bi decays by this beta decay.

(a) Complete the decay equation.

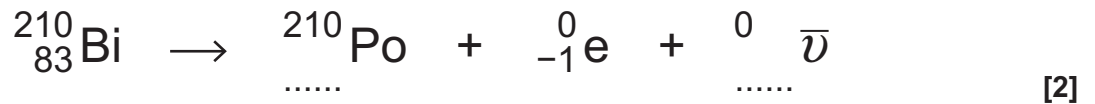

(b) State why an antineutrino is emitted during beta decay.

.....
..... [1]

- 34 A solar panel is charging a rechargeable battery, with a resistor R in series.

The values of the internal resistances r , the external resistance R and the e.m.f.s ε at the start of the charging process are shown in **Fig. 34**.

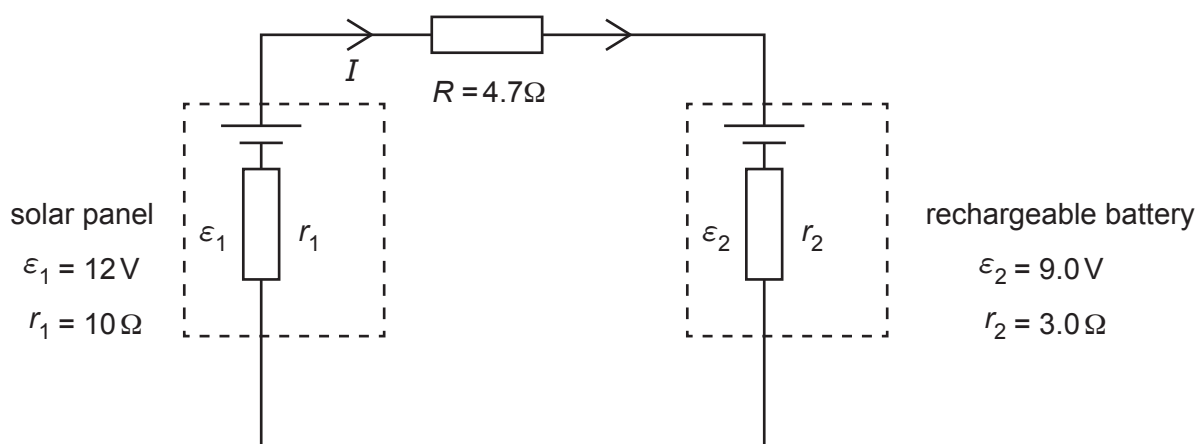

Fig. 34

- (a) Show that the initial current charging the rechargeable battery I is less than 0.2 A.

[2]

- (b) When fully charged, the rechargeable battery has enough charge to deliver an average current of 500 mA for an hour before it is fully discharged.

Estimate the time needed to recharge the battery at the mean charging current of 0.12 A.

time = hours [2]

- 35 This question is about a model of an atom with one electron. The electron is trapped in a box as shown in Fig. 35. Possible electron kinetic energy levels are plotted as shown.

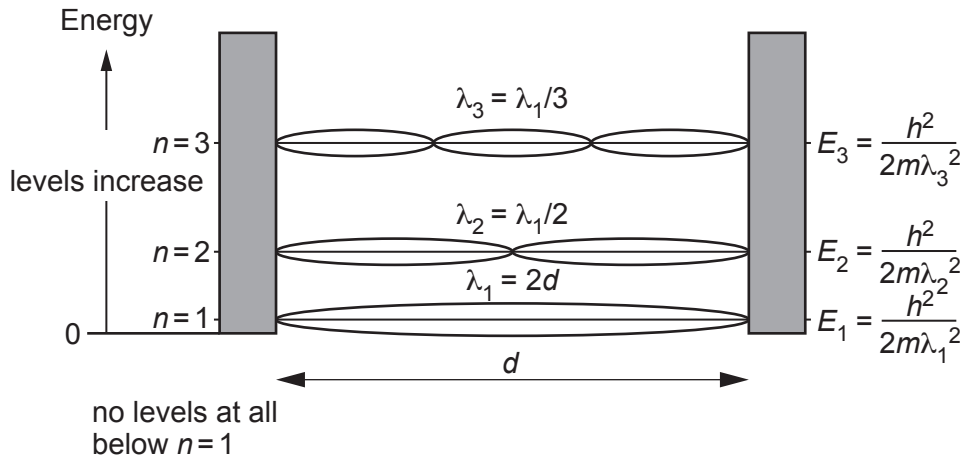

Fig. 35

- (a) Explain how this model gives rise to discrete quantised energy levels for the atom.

.....

 [2]

- (b) How many different frequencies of photon can be emitted from an atom with 3 energy levels?

..... [1]

- (c) The distance d between the walls of the box is about atomic size ≈ 0.10 nm.

Calculate the frequency of the most energetic photon that this model atom could emit.

frequency = Hz [3]

23
BLANK PAGE

PLEASE DO NOT WRITE ON THIS PAGE
Turn over for Section C

SECTION C

Answer **all** the questions.

36 This question considers some of the evidence for a Hot Big Bang start to our expanding universe.

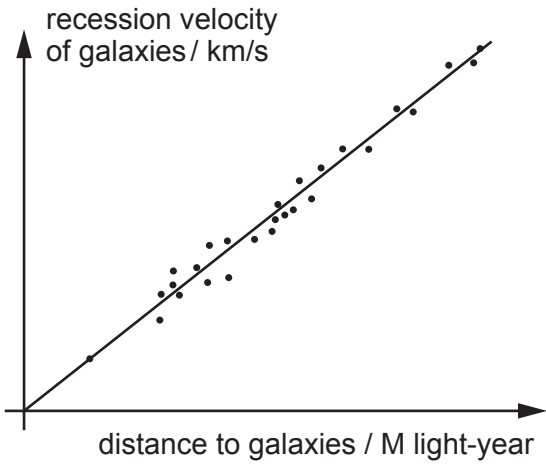

Fig. 36.1

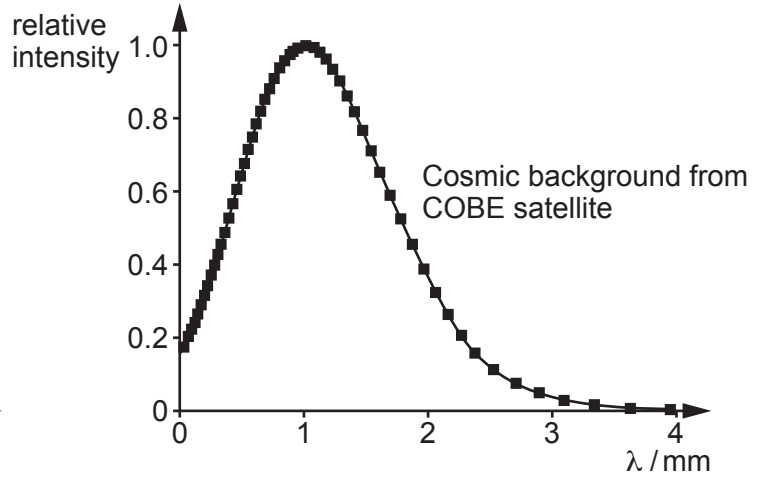

Fig. 36.2

(a) Explain how the graph(s) show evidence that the universe started from:

(i) a big bang expansion

.....
.....
.....
..... [2]

(ii) a hot state.

.....
.....
.....
..... [2]

- (b) The intensity spectrum of thermal radiation depends on temperature T . Photons at the **peak** of intensity have energy $\varepsilon \approx 5kT$.

Use this approximation and data from **Fig. 36.2** to estimate the temperature of the cosmic microwave background radiation (CMBR).

temperature = K [4]

37 This question is about propulsion systems for spacecraft.

(a) A solar sail uses the momentum of photons in solar radiation for propulsion.

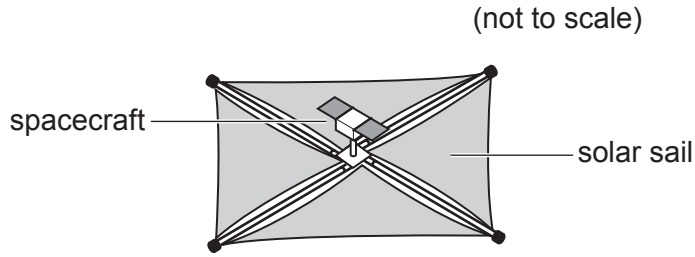

Fig. 37.1

Relativity shows that a photon of energy E has momentum $p = \frac{E}{c}$.

(i) Show that $\frac{E}{c}$ has the units of momentum.

[1]

(ii) The total photon power of the radiation received from the Sun on a 1.0 m^2 area of solar sail is P .

Show that the thrust force T from photon reflection is given by $T = \frac{2P}{c}$.

Assume that the Sun's rays are normal to the sail and all the radiation is reflected.

[3]

(iii) The total photon power density is 1400 W m^{-2} . The 1.0 tonne spacecraft has a 10^6 m^2 solar sail.

Calculate the acceleration of the spacecraft.

acceleration = ms^{-2} [2]

- (b) An ion drive uses the momentum of ions for propulsion. It ionises a gas and uses an accelerating field to accelerate the positive ions to a high velocity.

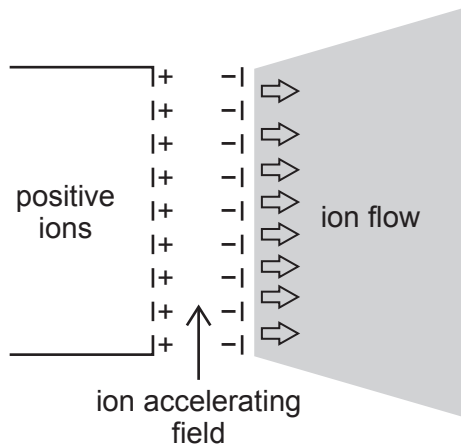

Fig. 37.2

- (i) A positive ion of charge Q and mass m is accelerated through a p.d. V . Show that the momentum per unit mass $\frac{p}{m}$ it gains is given by the expression

$$\frac{p}{m} = \sqrt{2V\left(\frac{Q}{m}\right)}.$$

[2]

- (ii) Discuss an advantage of using ions of hydrogen ${}^1\text{H}^+$ as propellant instead of xenon ${}^{130}\text{Xe}^+$.

.....

 [2]

- (iii) An ion drive with accelerating p.d. $V = 2000\text{V}$ must produce a thrust of 0.24N .

Show that the mass flow rate $\frac{\Delta m}{\Delta t}$ is less than $4 \times 10^{-7}\text{kg s}^{-1}$.

$\frac{Q}{m}$ for ${}^1\text{H}^+$ ions = $9.6 \times 10^7\text{C kg}^{-1}$.

[2]

38 A student performs Young's double slit experiment as shown in **Fig. 38.1**.

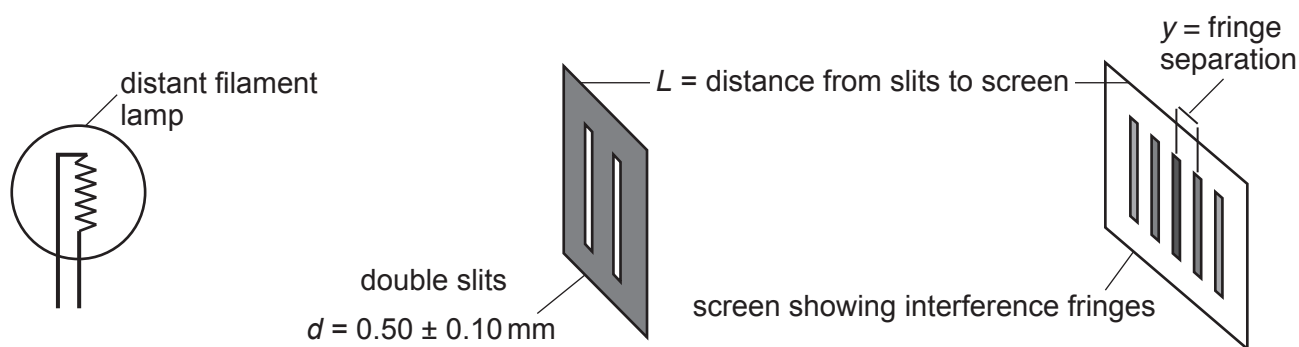

Fig. 38.1

The student investigates how the fringe spacing y varies with the distance L from slits to screen. The student measures the slit separation $d = 0.5 \pm 0.1 \text{ mm}$.

Fig. 38.2 shows the data obtained with uncertainties.

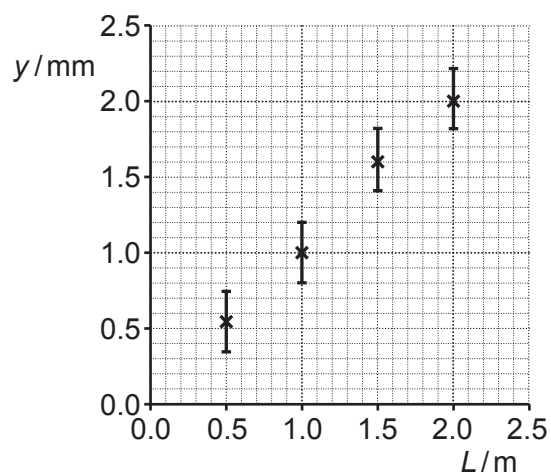

Fig. 38.2

(a) Suggest a reason why only uncertainties in the fringe spacing are shown on the graph.

.....
 [1]

- (b) Draw a line of best fit on the graph and measure its gradient with an uncertainty estimate.

gradient = \pm [3]

- (c) Use the gradient to estimate an average wavelength for the light together with an uncertainty estimate. Make your method clear.

wavelength = \pm m [3]

- (d) State **one** way in which you could refine or develop this practical design or procedure to reduce uncertainty.

.....
..... [1]

(b) Here are some data about trace gases in the atmosphere:

H₂ molar mass 2 grams
Xe molar mass 132 grams

(i) Calculate the ratio: $\frac{\text{speed of hydrogen molecule with average kinetic energy}}{\text{speed of xenon atom with average kinetic energy}}$.

Make your reasoning clear.

ratio = [3]

(ii) The escape velocity for planet Earth is 11.2 km s⁻¹.

Use the Boltzmann factor to estimate the number of H₂ molecules per mole with sufficient energy to escape the atmosphere and the Earth's gravitational field at a temperature of 288 K.

number = mole⁻¹ [4]

- 40 Fig. 40.1 shows a simplified diagram of a d.c. motor with permanent magnets.
 Fig. 40.2 shows the graph of current in the coil against frequency of rotation for this motor.

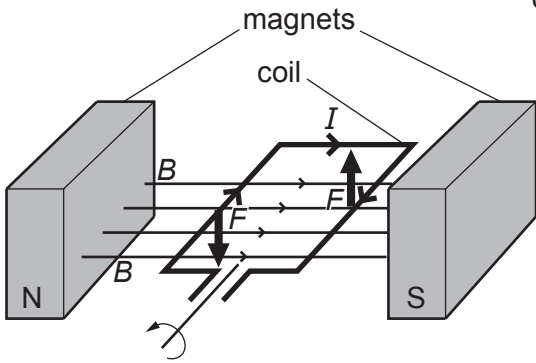

Fig. 40.1

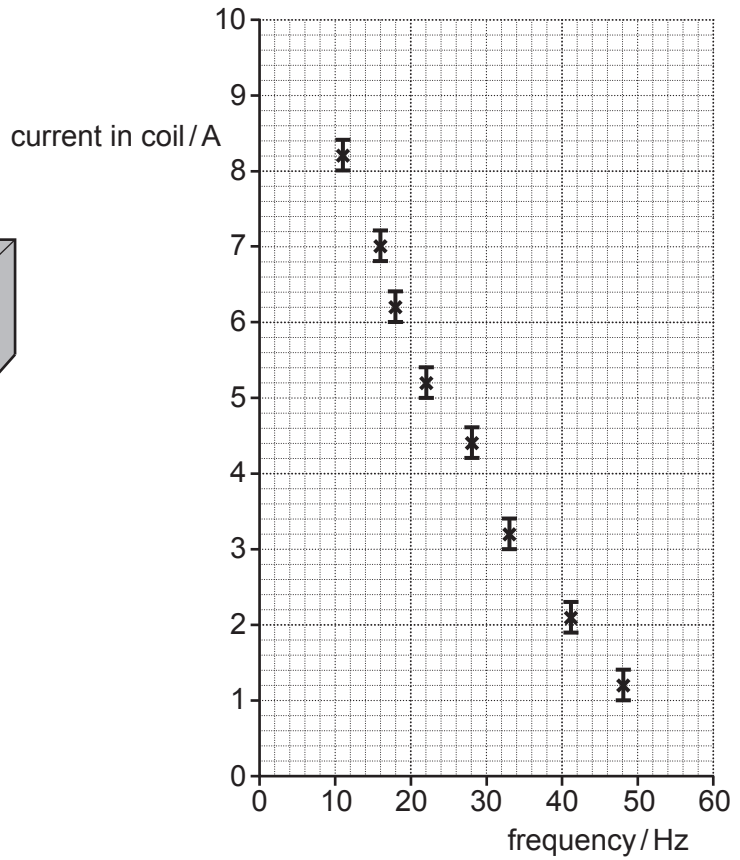

Fig. 40.2

The coil is connected to a 12.0V supply of negligible internal resistance shown in Fig. 40.1. This produces the force to keep the motor turning against a mechanical load.

- (a) Draw a **straight line** of best fit on Fig. 40.2 and use it to predict the current in the coil when the motor is not rotating.
 Use your prediction to calculate the resistance of the coil.

resistance = Ω [3]

41 This question is about the electric field around protons.

- (a) Two protons are separated by $1.0 \times 10^{-9} \text{ m}$ as shown in **Fig. 41.1**. Point **X** is equidistant from each proton as shown.

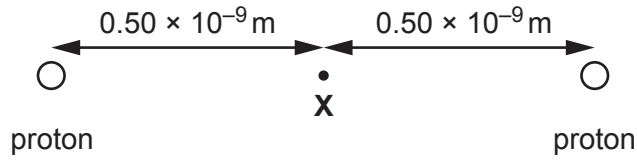

Fig. 41.1 not to scale

- (i) Explain why the electric field strength at **X** is zero.

.....

 [1]

- (ii) Calculate the electric potential at **X**.

potential = V [2]

Question 41 continues on page 35

(b) Imagine a third proton is positioned as shown in **Fig. 41.2**.

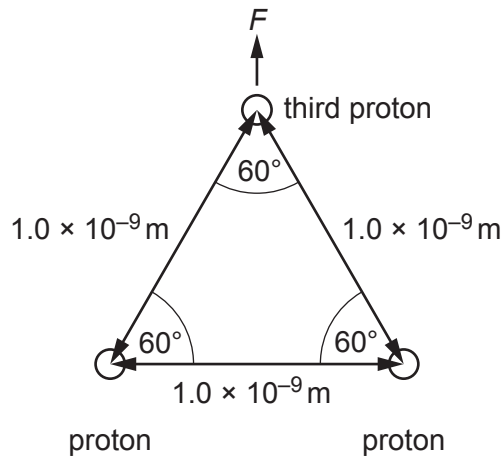

Fig. 41.2 not to scale

(i) Show that the resultant force F on the third proton is about $4 \times 10^{-10} \text{ N}$ in the direction shown. Explain your reasoning. You may include a diagram in your answer.

.....

.....

.....

..... [4]

(ii) The separation of protons in a lithium ${}^6_3\text{Li}$ nucleus is of the order of 10^{-15} m . Estimate the magnitude of the resultant electric force on a proton in the nucleus if the protons are arranged symmetrically as in **Fig. 41.2**.

force = N [2]

END OF QUESTION PAPER

ADDITIONAL ANSWER SPACE

If additional space is required, you should use the following lined page(s). The question number(s) must be clearly shown in the margin(s).

A large rectangular area with a solid vertical line on the left side and horizontal dotted lines across the rest of the page, providing space for writing answers.



Copyright Information

OCR is committed to seeking permission to reproduce all third-party content that it uses in its assessment materials. OCR has attempted to identify and contact all copyright holders whose work is used in this paper. To avoid the issue of disclosure of answer-related information to candidates, all copyright acknowledgements are reproduced in the OCR Copyright Acknowledgements Booklet. This is produced for each series of examinations and is freely available to download from our public website (www.ocr.org.uk) after the live examination series.

If OCR has unwittingly failed to correctly acknowledge or clear any third-party content in this assessment material, OCR will be happy to correct its mistake at the earliest possible opportunity.

For queries or further information please contact the Copyright Team, First Floor, 9 Hills Road, Cambridge CB2 1GE.

OCR is part of the Cambridge Assessment Group; Cambridge Assessment is the brand name of University of Cambridge Local Examinations Syndicate (UCLES), which is itself a department of the University of Cambridge.