



Oxford Cambridge and RSA

A Level Physics B (Advancing Physics)

H557/01 Fundamentals of Physics

Practice paper – Set 2

Time allowed: 2 hours 15 minutes

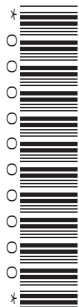

You must have:

- The Data, Formulae and Relationships Booklet

You may use:

- a scientific or graphical calculator
- a ruler (cm/mm)

First name										
Last name										
Centre number						Candidate number				

INSTRUCTIONS

- Use black ink. You may use an HB pencil for graphs and diagrams.
- Complete the boxes above with your name, centre number and candidate number.
- Answer **all** the questions.
- Write your answer to each question in the space provided. If additional space is required, use the lined page(s) at the end of this booklet. The question number(s) must be clearly shown.
- Do **not** write in the barcodes.

INFORMATION

- The total mark for this paper is **110**.
- The marks for each question are shown in brackets [].
- Quality of written communication will be assessed in this paper.
- This document consists of **40** pages.

2
SECTION A

You should spend a maximum of 40 minutes on this section.

Write your answer for each question in the box provided.

Answer **all** the questions.

1 Which unit could be used for conductance?

A $W A^{-1}$

B $A^2 \Omega$

C $V A^{-1}$

D $A V^{-1}$

Your answer

[1]

2 Which of the following pairs consist of one scalar and one vector?

A acceleration displacement

B force distance

C temperature energy

D work density

Your answer

[1]

- 3 A slide projector is set up to give a focused image on a fixed screen.

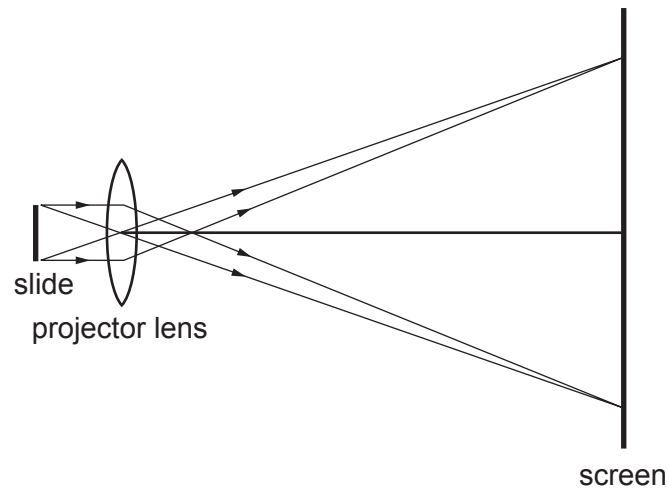

Which set of adjustments could give a larger focused image on the screen?

	Movement of slide	Movement of projector
A	away from the lens	away from the screen
B	away from the lens	towards the screen
C	towards the lens	away from the screen
D	towards the lens	towards the screen

Your answer

[1]

- 4 A thin converging lens of focal length f produces a real image.

Which of the following is correct?

When the object distance is

- A** very large the image distance is $2f$.
- B** f the magnification M is 1.
- C** $2f$ the image distance is f .
- D** larger than f but smaller than $2f$ the magnification M is larger than 1.

Your answer

[1]

- 5 An analogue signal with a maximum frequency of 6 kHz is to be digitised.

For the signal $\frac{V_{\text{Total}}}{V_{\text{Noise}}} = 2000$

what is the best estimate of the bit rate needed for the digitised signal?

- A 12 Mbit s⁻¹
- B 24 Mbit s⁻¹
- C 66 kbit s⁻¹
- D 132 kbit s⁻¹

Your answer

[1]

- 6 Two wires of the same length and the same material are connected in parallel across the same battery of negligible internal resistance. Wire X has double the diameter of wire Y.

What is the ratio $\frac{\text{current in X}}{\text{current in Y}}$?

- A $\frac{1}{4}$
- B $\frac{1}{2}$
- C 2
- D 4

Your answer

[1]

7 These two circuits have identical components.

The cells have internal resistance $r = \frac{R}{2}$.

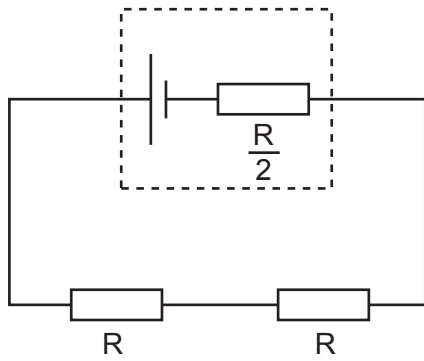

circuit 1

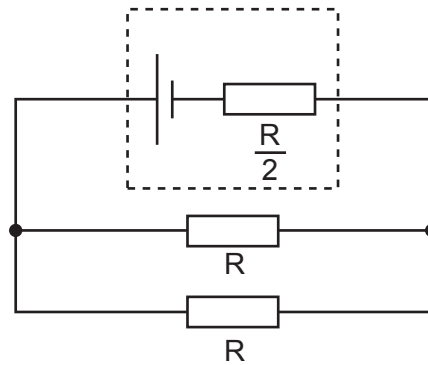

circuit 2

What is the ratio $\frac{\text{total resistance of circuit 1}}{\text{total resistance of circuit 2}}$?

- A $\frac{5}{2}$
- B $\frac{2}{5}$
- C $\frac{3}{2}$
- D $\frac{2}{3}$

Your answer

[1]

The following information is for use in questions 8 and 9.

The graph shows how the length of a plastic rod varies with the force in it. The rod snaps at **Q**, when its cross-sectional area is $2 \times 10^{-6} \text{ m}^2$.

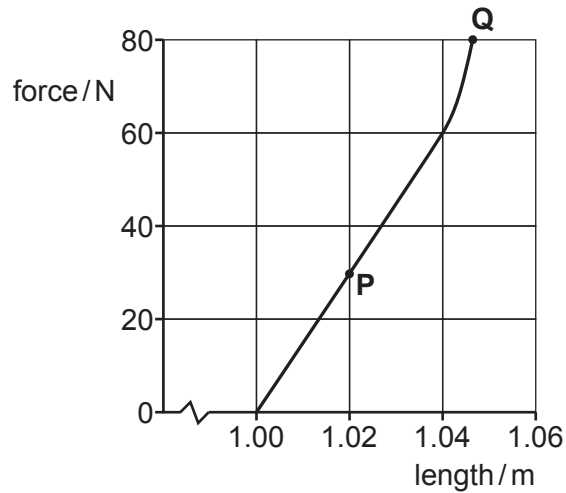

8 What is the best estimate for the Young modulus of the plastic?

- A 10^3 Pa
- B 10^6 Pa
- C 10^9 Pa
- D 10^{11} Pa

Your answer

[1]

9 Which of the following statements is correct?

- A The breaking stress is $4.0 \times 10^7 \text{ N m}^{-2}$.
- B Hooke's Law is obeyed up to a force of 60 N.
- C The stress at **P** is 0.2%.
- D The strain at **P** is 0.02%.

Your answer

[1]

10 A microwave transmitter **T** is placed at a fixed distance from a flat reflecting surface **S**.

A receiver **R** is moved from **S** towards **T**. The signal received changes in intensity as indicated in the diagram.

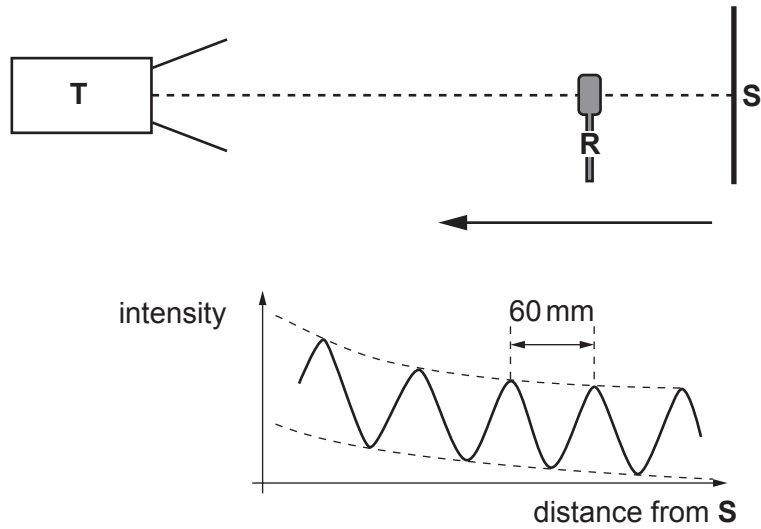

Which of the following statements is correct?

- A** The receiver **R** is measuring the amplitude of a standing wave pattern.
- B** The frequency of the microwaves is 2.5 GHz.
- C** The wavelength of the microwaves is 6.0 cm.
- D** The amplitudes of the transmitted and reflected waves at each position are equal.

Your answer

[1]

- 11 A motorbike launches horizontally from a point 1.25 m above ground, and lands 10 m away as shown.

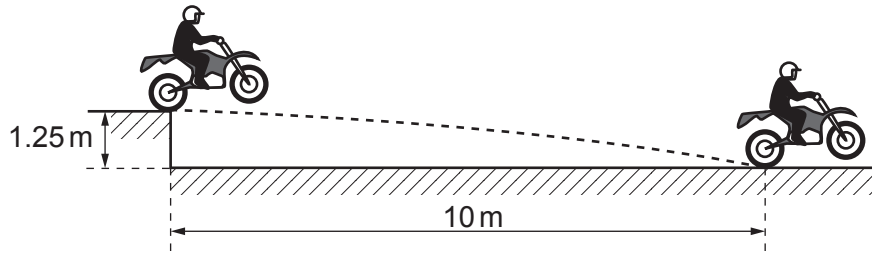

What was the speed at launch?

- A 5 ms^{-1}
- B 10 ms^{-1}
- C 15 ms^{-1}
- D 20 ms^{-1}

Your answer

[1]

- 12 A motorist travelling at 10 ms^{-1} brings her car to rest in a braking distance of 10 m.

In what braking distance could she bring the car to rest from an initial speed of 40 ms^{-1} using the same braking force under the same road conditions?

- A 20 m
- B 40 m
- C 80 m
- D 160 m

Your answer

[1]

13 A ball falls from rest through air. It reaches terminal velocity.

For this fall forces X and Y vary with time as shown.

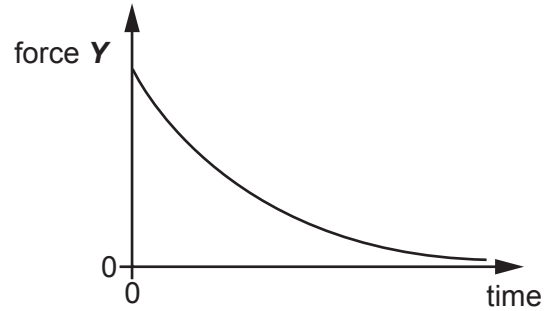
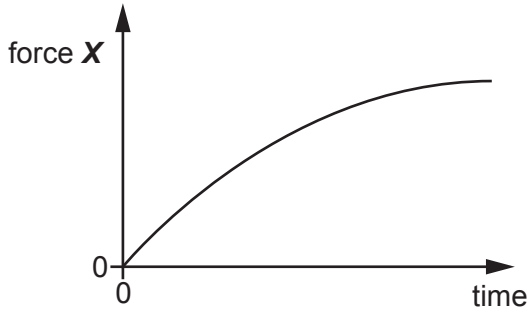

What are the forces X and Y ?

	Force X	Force Y
A	air resistance	resultant force
B	air resistance	weight
C	weight	resultant force
D	resultant force	weight

Your answer

[1]

14 A student makes measurements and calculates the speed of sound as 328.16 m s^{-1} .
The experimental uncertainty is $\pm 3\%$.

Which of the following expresses the result to an appropriate number of significant figures?

- A 300 m s^{-1}
- B 330 m s^{-1}
- C 328 m s^{-1}
- D 328.2 m s^{-1}

Your answer

[1]

- 15 The mass attached to a spring undergoes simple harmonic motion.

The spring has a spring constant of 25 N m^{-1} .

What is the best estimate for the time period T of the simple harmonic oscillations?

- A 0.14 s
- B 0.90 s
- C 1.1 s
- D 7.1 s

Your answer

[1]

- 16 After 64 days the activity of a radioactive nuclide has fallen to one sixteenth $\left(\frac{1}{16}\right)$ of its original value.

What is the half-life of the radioactive nuclide?

- A 2 days
- B 4 days
- C 8 days
- D 16 days

Your answer

[1]

- 17 A ball of mass m is suspended on a string from a stick which is rotated at angular speed ω as illustrated below.

The ball moves in a horizontal circle of radius R . The tension in the string is T and the angle of the string to the vertical is θ .

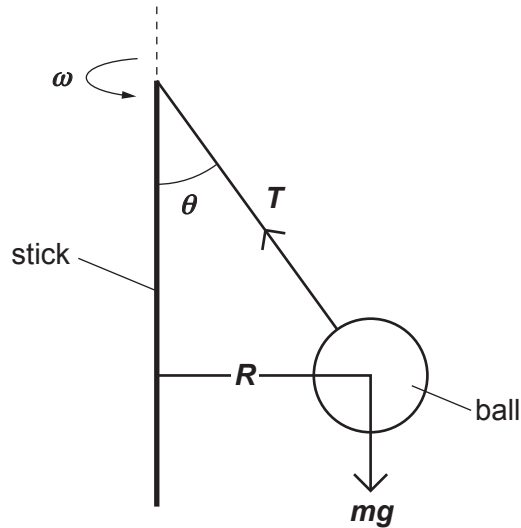

What are the equations for the vertical and horizontal force components of the motion?

	Vertical resolution	Horizontal resolution
A	$mg = T \sin \theta$	$T \cos \theta = m R^2 \omega$
B	$mg = T \sin \theta$	$T \cos \theta = m R \omega^2$
C	$mg = T \cos \theta$	$T \sin \theta = m R^2 \omega$
D	$mg = T \cos \theta$	$T \sin \theta = m R \omega^2$

Your answer

[1]

- 18 Which graph shows the correct relationship between the relativistic γ factor and the speed v of a moving particle?

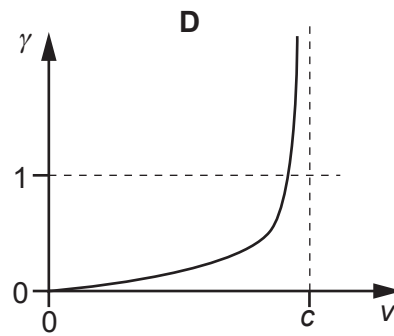
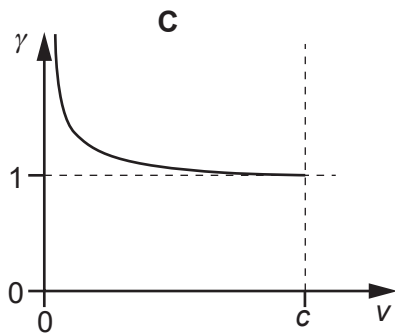
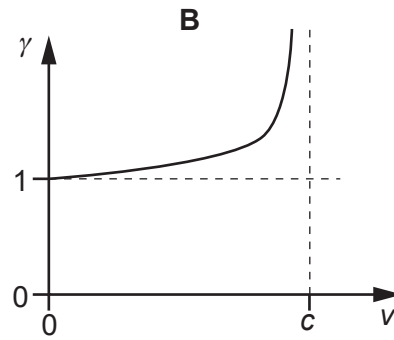
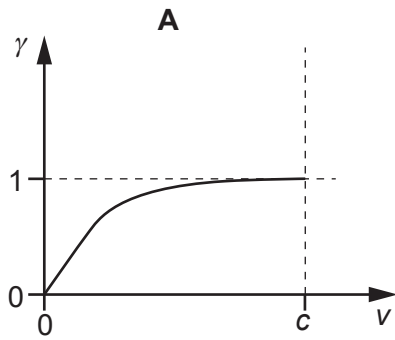

Your answer

[1]

- 19 Which is the best estimate for the order of magnitude of the energy, in electronvolts, of a photon of visible light?

- A** 10^{-19} eV
B 10^{-10} eV
C 1 eV
D 10^{19} eV

Your answer

[1]

The following information is for use in questions 20 and 21.

This diagram shows an ideal transformer.

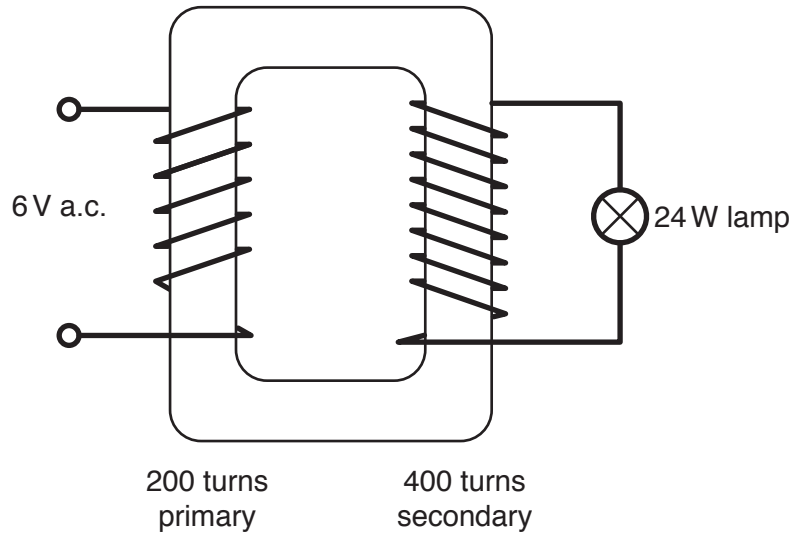

Here are four values of currents:

- A $\frac{1}{4}$ A
- B $\frac{1}{2}$ A
- C 2 A
- D 4 A

20 Which is the best estimate of the current in the secondary circuit?

Your answer

[1]

21 Which is the best estimate of the current in the primary circuit?

Your answer

[1]

22 Protons and neutrons consist of smaller particles called quarks.

The 'up' quark has a charge $+\frac{2}{3}e$ and the 'down' quark has a charge $-\frac{1}{3}e$, where e is the elementary charge.

How many up quarks and down quarks must a proton contain?

	Up quarks	Down quarks
A	0	3
B	1	1
C	1	2
D	2	1

Your answer

[1]

23 The grid shows the number of nucleons and the number of protons for different nuclides.

number of nucleons

237				Np		
236		A				
235				C	D	
234						
233				B		
	89	90	91	92	93	94

number of protons

The isotope of Neptunium (Np) shown on the grid decays by emitting an alpha particle and then a beta particle.

Which box represents the resulting nuclide?

Your answer

[1]

- 24 A nucleus X interacts with a neutron and undergoes fission:

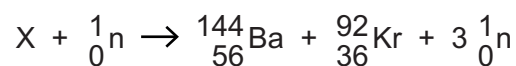

What is nucleus X?

- A ${}_{92}^{234}\text{U}$
- B ${}_{92}^{238}\text{U}$
- C ${}_{92}^{235}\text{U}$
- D ${}_{93}^{237}\text{Np}$

Your answer

[1]

- 25 A fixed mass of gas occupies a volume V . The temperature of the gas increases so that the root mean square speed of the molecules doubles. The pressure remains constant.

What is the new volume of the gas?

- A $\frac{V}{2}$
- B $\frac{V}{\sqrt{2}}$
- C $2V$
- D $4V$

Your answer

[1]

26 Two large gas bottles are connected by a tube of negligible volume as shown.

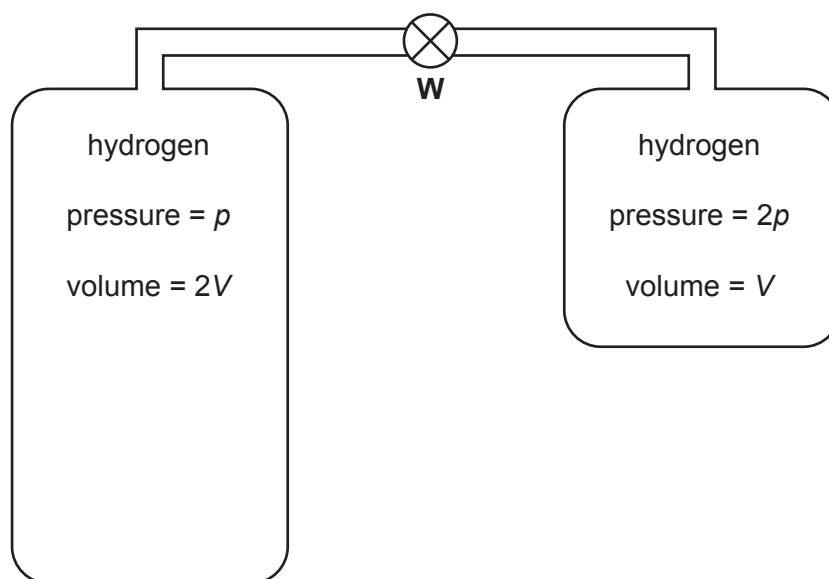

Initially the valve **W** is closed.

Valve **W** is opened so that gas can slowly flow, but remain at room temperature.

What is the new gas pressure in the bottles when flow has stopped?

- A $\frac{2}{3}p$
- B $\frac{4}{3}p$
- C $\frac{3}{2}p$
- D $\frac{5}{3}p$

Your answer

[1]

- 27 A satellite with orbital speed v takes 24 hours to make one orbit of the Earth, remaining stationary above a fixed point on the Earth's surface.

Which of the following statements is/are correct?

- 1 Any radius R of orbit is possible, provided that $\frac{2\pi R}{v} = 24$ hours.
- 2 It must be in an orbit above the equator.
- 3 Any mass of satellite can be chosen.

- A 1, 2 and 3 are correct
B only 1 and 2 are correct
C only 2 and 3 are correct
D only 1 is correct

Your answer

[1]

- 28 10 kg of water at 90 °C is mixed with 30 kg of water at 30 °C in a warm bath.

Assume there is no energy transferred by heating to the surroundings.

Which of the following statements is/are correct?

- 1 Energy transferred by heating from the hotter water = energy transferred by heating to the cooler water.
- 2 The temperature drop of hotter water = 3 × temperature rise of cooler water.
- 3 The final temperature of the mixture will be 45 °C.

- A 1, 2 and 3 are correct
B only 1 and 2 are correct
C only 2 and 3 are correct
D only 1 is correct

Your answer

[1]

- 29 A thick aluminium disc has its plane perpendicular to a uniform magnetic field as in Fig. 29.1. The disc is then turned through 90° until its plane is parallel to the magnetic field as in Fig. 29.2.

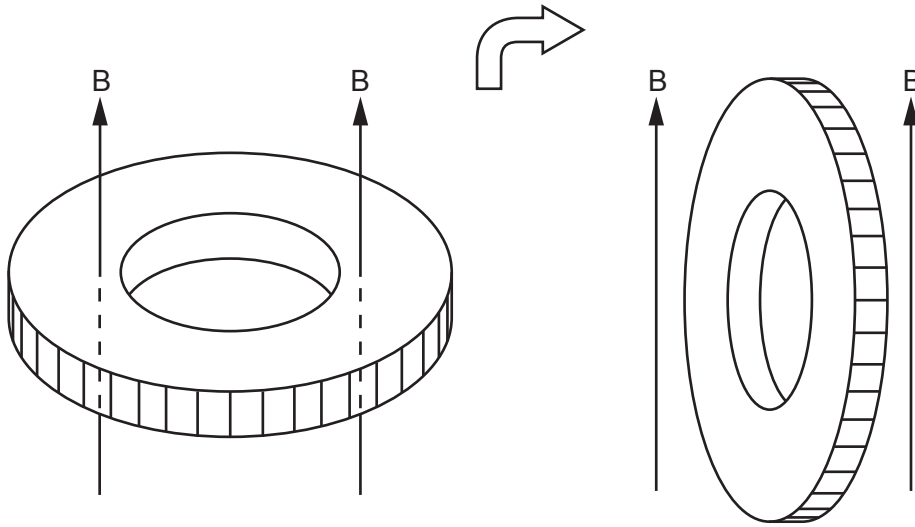

Fig. 29.1

Fig. 29.2

The movement cuts magnetic flux, so there is an induced e.m.f. and hence an induced current is produced in the disc.

This **induced current** could be increased by

- A increasing the size of the central hole.
- B increasing the speed of turning the disc.
- C using metal of a lower conductivity for the disc.
- D turning the disc in the opposite direction.

Your answer

[1]

- 30 An α particle approaches an atomic nucleus and is scattered through angle θ . The path of the particle is offset as shown.

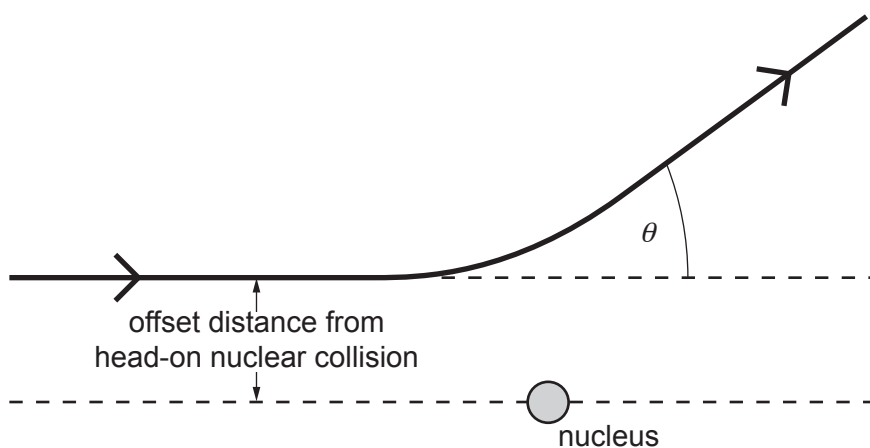

Which of the following changes on its own would cause the scattering angle θ to decrease?

- A Use an α particle with lower kinetic energy.
- B Have a smaller offset distance for the initial trajectory.
- C Use a target nucleus with a smaller charge.
- D Use a target nucleus with a larger mass.

Your answer

[1]

SECTION B

Answer **all** the questions.

- 31 (a) Show that the gravitational potential at the surface of the Earth is about -63 MJ kg^{-1} .

$$\text{mass of Earth} = 6.0 \times 10^{24} \text{ kg}$$

$$\text{radius of Earth} = 6.4 \times 10^6 \text{ m}$$

[2]

- (b) Fig. 31.1 shows the gravitational equipotential at the surface of the Earth.

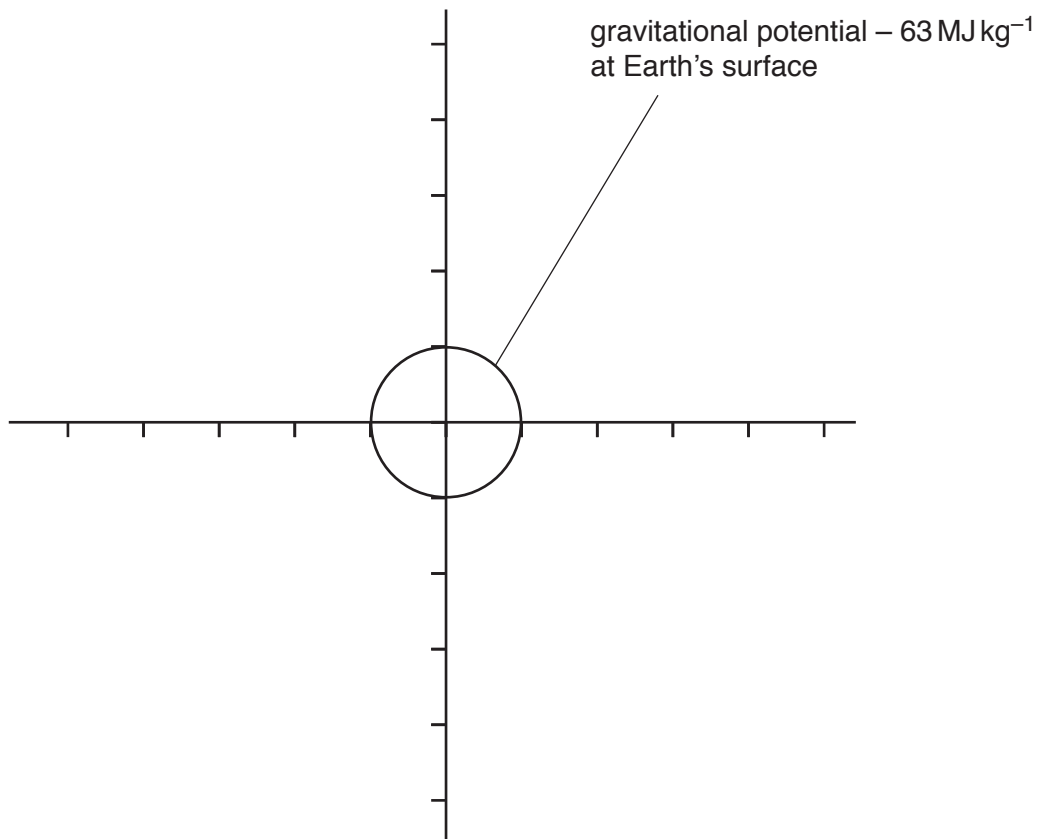

Fig. 31.1

On Fig. 31.1 draw the equipotential line for the Earth at -15.5 MJ kg^{-1} .

[2]

- (c) The magnitude of the Earth's gravitational field strength at the surface is 9.8 N kg^{-1} .

Estimate the magnitude of the radial gravitational field on the -15.5 MJ kg^{-1} equipotential.

gravitational field strength = N kg^{-1} [2]

- 32 A glider on a friction free air track has a mass of 0.40 kg and a velocity of 0.36 m s^{-1} . It has a collision with a stationary glider and they stick together and move forward. After collision the combined gliders have a velocity of 0.16 m s^{-1} .

- (a) Calculate the mass of the stationary glider.

mass = kg [2]

- (b) Show that the magnitude of the impulse on one glider during the collision is less than 0.1 N s .

[2]

33 This question is about modelling the decay of charge from a capacitor using iteration in discrete time intervals Δt .

(a) The iterations are calculated using this model:

$$\Delta Q = -I \Delta t = -\frac{V}{R} \Delta t = -\frac{Q}{RC} \Delta t$$

State the assumption that is made.

.....
 [1]

(b) In the model $\Delta t = 10\text{ s}$ and the time constant for the circuit $RC = 25\text{ s}$.

State and explain how the model could be made to be a more accurate representation of the decay.

.....

 [2]

(c) In the table below, the first row sets up the initial conditions. Values in following rows are calculated by iteration using the model rules.

t elapsed / s	Charge Q on capacitor / mC	Charge lost during $\Delta t = \frac{Q}{RC} \Delta t$ / mC
0	50	20
10	30	
20		

Complete the empty boxes in the table. [2]

34 This question is about a simplified model of the refraction of light by the Earth's atmosphere.

The model assumes that the Earth's atmosphere is of uniform density and there is a sudden change of medium between the edge of the atmosphere and the vacuum of space. Fig. 34.1 shows this situation.

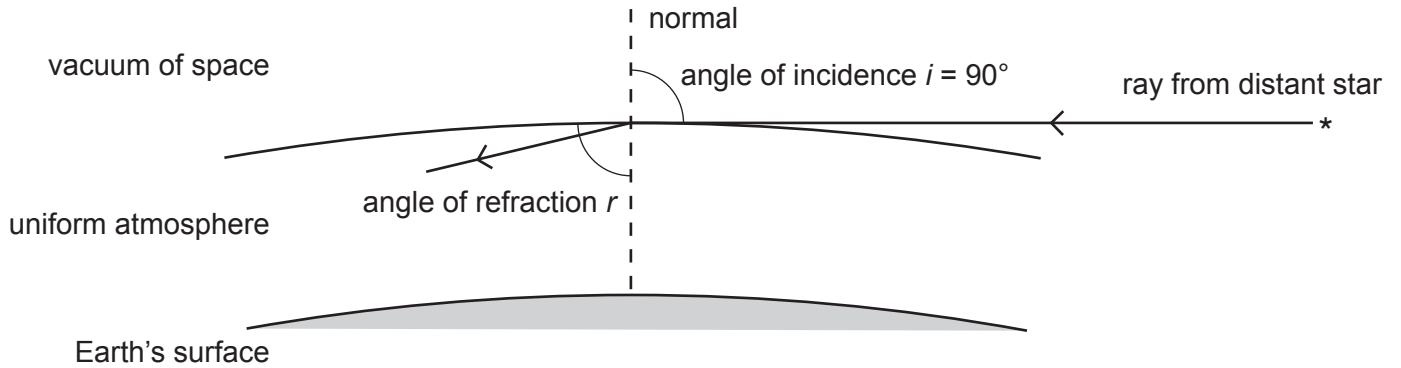

Fig. 34.1

- (a) A ray of light from a star arrives at the atmosphere at an angle of incidence i of 90° . The refractive index n of the atmosphere is 1.00029.

Calculate the angle of refraction r inside the Earth's atmosphere.

$r = \dots\dots\dots^\circ$ [2]

- (b) Suggest and explain an effect that this refraction might have on the image of the setting Sun.

.....

 [2]

- (c) The refractive index of the Earth's atmosphere decreases exponentially with height. Suggest and explain an effect this would have on the path of the refracted ray in the atmosphere.

.....

 [2]

35 Fig. 35.1 shows two hydrogen spectra, on the same wavelength scale. One is from a laboratory reference frame and the other from a distant, receding cloud of hydrogen gas.

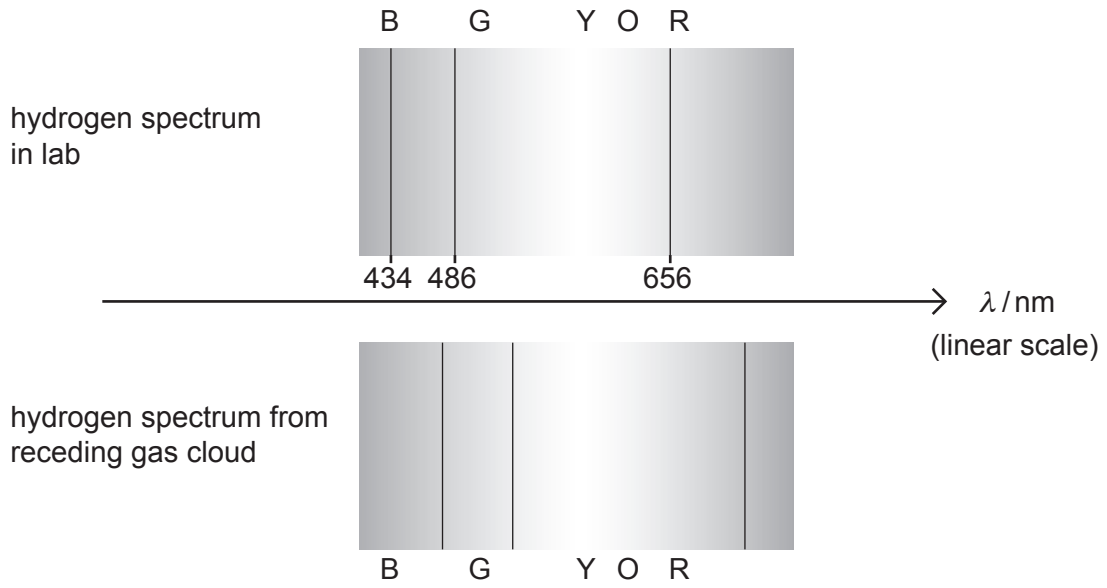

Fig. 35.1

(a) Compare features of the spectra and explain how they support the idea of Doppler red-shift.

.....

.....

.....

.....

..... [2]

(b) Use the non-relativistic Doppler shift equation $\frac{\Delta\lambda}{\lambda} = \frac{v}{c}$

to show that the recession velocity v of the distant hydrogen gas cloud is about $0.1c$.

[3]

SECTION C

Answer **all** the questions.

36* A student missed the lesson when the topic of **resonance of simple harmonic oscillators** was introduced. You are asked to make notes and labeled diagrams to help explain these ideas and enable the student to catch up.

In your answer include a description of an experiment that illustrates and explains the resonance of a simple harmonic oscillator, including the effect of damping.

.....

.....

.....

.....

.....

.....

.....

.....

.....

.....

.....

.....

.....

.....

.....

.....

.....

.....

.....

.....

.....

.....

.....

A series of 25 horizontal dotted lines for writing.

[6]

37 Fig. 37.1 shows a toy rocket of mass 0.030 kg about to be launched vertically from a compressed spring that obeys Hooke's Law.

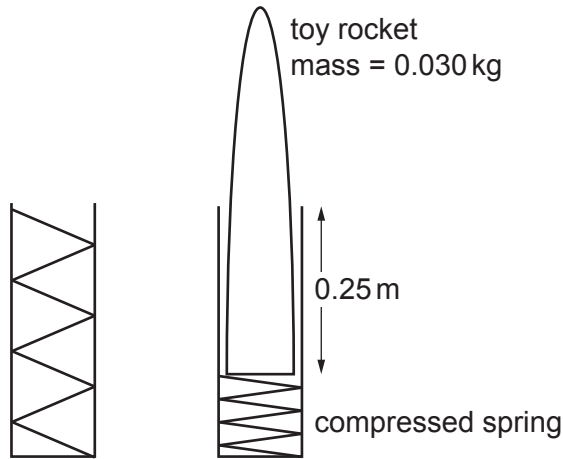

Fig. 37.1

The spring is compressed by 0.25 m by a force of 18 N.

(a) Calculate the maximum height that the toy rocket could reach. State any assumptions you make.

maximum height = m [3]

(b) In reality the toy rocket would not reach as high as you calculated in (a). Suggest and explain one possible reason for this shortfall.

.....

 [2]

(c) The spring vertically launches a ball bearing of mass equal to the rocket. Suggest and explain how the height reached by the ball bearing might be different to the rocket.

.....

 [2]

38 This question is about strain gauges that can be fixed to an object to measure its extension or compression.

(a) Fig. 38.1 shows a strain gauge. It is made of strips of **very thin** metallic foil in a series **zig-zag** format.

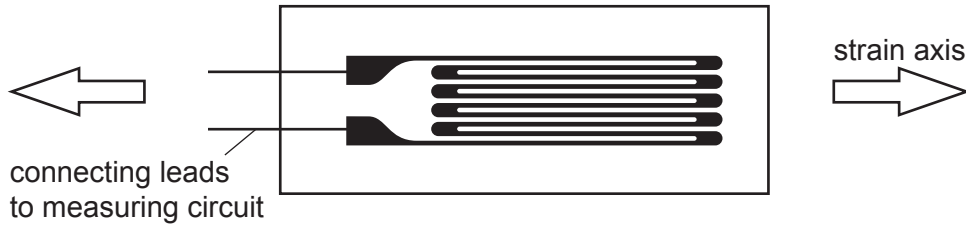

Fig. 38.1

(i) State why the foil gauge is made in this shape.

.....
 [1]

(ii) The strain gauge has a resistance R of $350.0 \pm 0.05 \Omega$. A student measures the resistance R using connecting leads and an ohmmeter, as shown in Fig. 38.2. The ohmmeter reading is accurate to 5 s.f. and measures 350.90Ω .

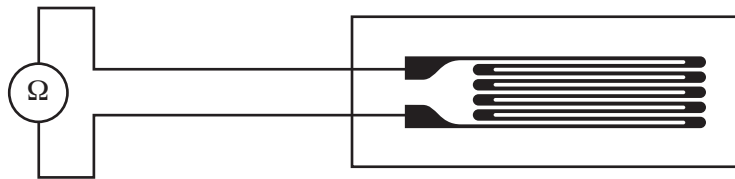

Fig. 38.2

Suggest an explanation for this systematic error.

.....
 [1]

- (b) To make a sensing circuit the student connects a potential divider circuit with the strained gauge **X** connected in series with another identical, unstrained strain gauge **Y** as shown in Fig. 38.3.

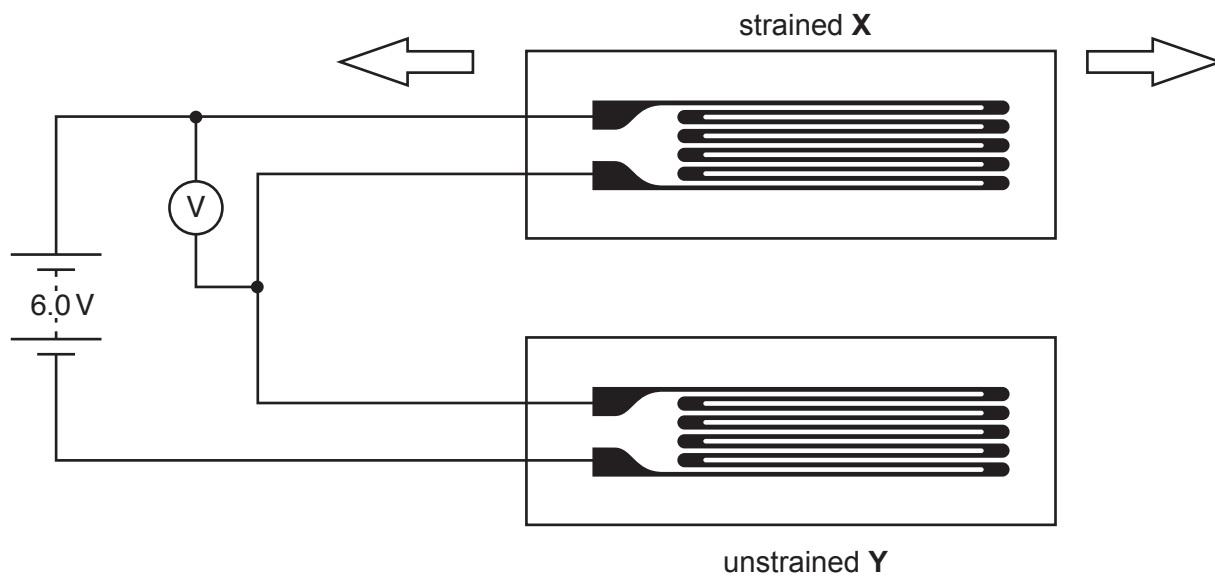

Fig. 38.3

Question 38 part b continues on page 30

(i) Fig. 38.4 shows the calibration graph for this strain sensor.

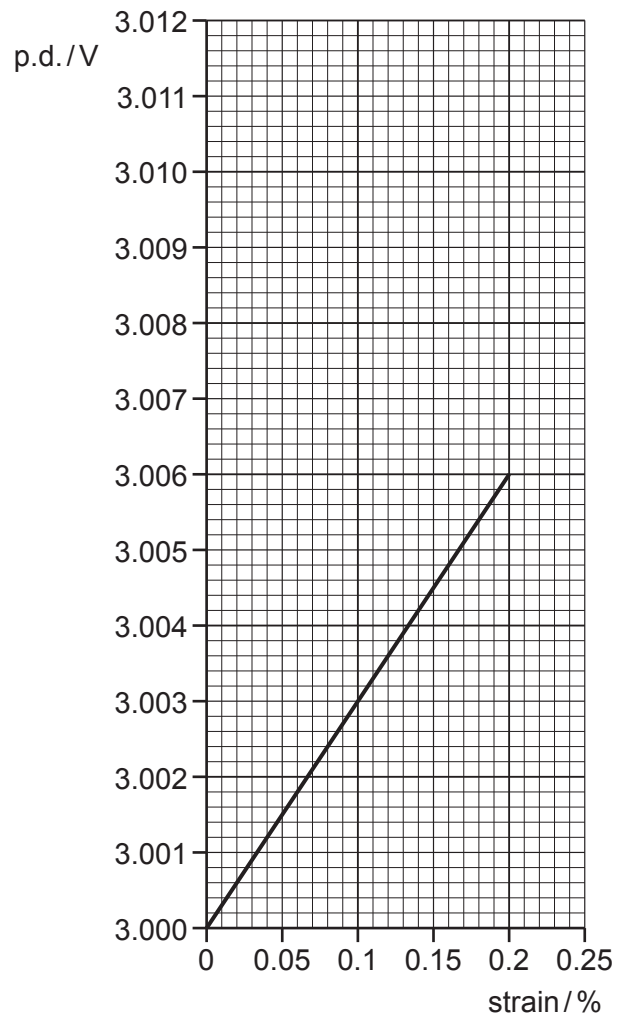

Fig. 38.4

Use data from Fig. 38.4 to calculate the sensitivity of the strain gauge sensor.

sensitivity =V unit strain⁻¹ [2]

39 Juno is a satellite mission to Jupiter. Fig. 39.1 shows an image it captured as it passed the Earth.

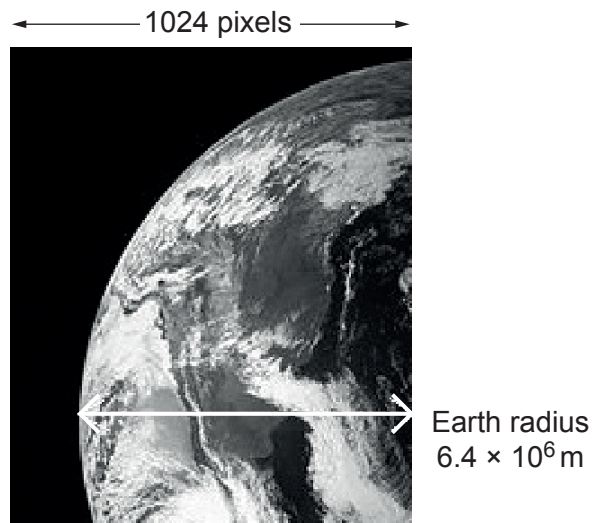

Fig. 39.1

(a) The camera forms an image on a sensor of 1224×1024 pixels. It records three-colour (RGB) intensity using 10 bits per colour per pixel.

(i) Show that the information in a full uncompressed image is less than 40 Mbits.

[1]

(ii) An Earth radius ($= 6.4 \times 10^6$ m) is indicated on the image. Estimate the resolution of the image in Fig. 39.1. Make your method clear.

resolution = m pixel⁻¹ [2]

.....
.....
.....
.....
.....
.....
.....

..... [6]

(c) The satellite transmits information at 340 bits s^{-1} .

Calculate the amount of information in bytes that can be transmitted in 24 hours.

information = Mbytes [2]

40 This question is about a circular particle accelerator called a cyclotron.

The cyclotron consists of two hollow semicircular metal “dees”, dee 1 and dee 2, in a vacuum. The dees are in a uniform magnetic field B of 0.80 T and are separated by a narrow gap as shown in Fig. 40.1.

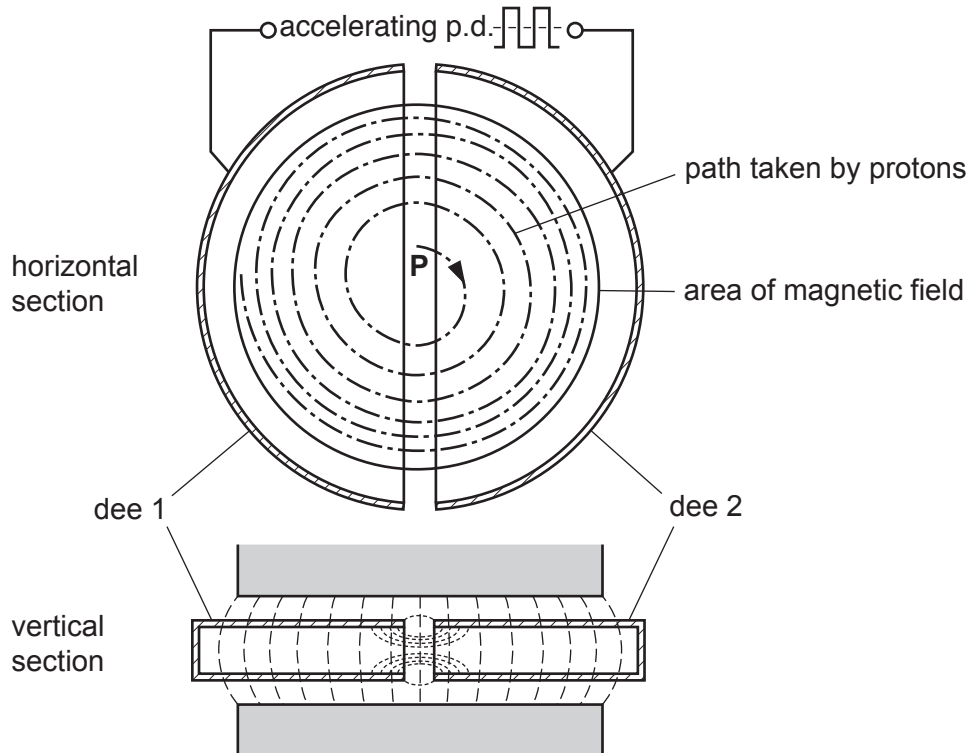

Fig. 40.1

Protons are injected into the gap between the dees at **P** and are accelerated by the electric field between the dees. The dees are horizontal and the magnetic field is in the vertical direction. The protons move in horizontal semi-circular paths within the dees, the path diameter increases after each crossing of the gap.

Show that the protons of mass m and charge q move in a circular path of radius $r = \frac{mv}{Bq}$ with constant speed v inside each dee. Assume non-relativistic conditions.

.....
 [2]

(b) (i) Show that the time T to travel around a semi-circle within a dee is independent of v .

[1]

(ii) State the implication this has on the frequency of the alternating accelerating p.d. across the dees.

.....
 [1]

(iii) The frequency f of the accelerating p.d. is given by $f \approx \frac{1}{2T} = \frac{Bq}{2\pi m}$.

Calculate this frequency for protons in a uniform magnetic field of 0.80 T.

frequency = Hz [1]

(iv) Each time the protons cross the gap between the dees they are accelerated through a p.d. of 5.0 kV.

Calculate the number of loops in their spiral path that is needed to accelerate them to an energy of 1.2 MeV.

number = [2]

(v) Use the relativistic factor γ to show that a non-relativistic approach for this cyclotron is a reasonable approximation.

rest energy of proton = 940 MeV

[2]

- 41 This question is about the first three minutes of the big bang, the formation of protons and neutrons and their fusion to produce the first nuclei of hydrogen and helium.
The table shows a time line at some interesting moments.

Time from big bang / s	0.02	1.1	180
Temperature / K	10^{11}	10^{10}	10^9
Energy kT / MeV	8.8	0.88	0.088
Density / kg m^{-3}	3.8×10^{12}	3.8×10^8	3.8×10^4

The big bang represents an incredibly hot and dense state of matter that was rapidly expanding and cooling.

- (a) (i) Show that at a temperature of 10^{11} K the thermal energy of particles and photons is around 9 MeV per particle.

[1]

- (ii) Show that electron and positron pairs can easily be created from photon collisions at 10^{11} K

[2]

- (iii) Explain why the creation of proton – antiproton pairs requires an earlier, hotter period of time during the big bang.

.....

 [1]

- (b) Free neutrons decay into protons with the emission of an electron and antineutrino. Free neutrons have a half-life of about 10 minutes. Once bound in a nucleus they become stable. Neutrons are more massive than protons.

$$m_{\text{PROTON}} = 1.007276 \text{ u} \quad m_{\text{NEUTRON}} = 1.008665 \text{ u} \quad m_{\text{ELECTRON}} = 0.000549 \text{ u}$$

$$1 \text{ u} = 1.661 \times 10^{-27} \text{ kg} = 931.3 \text{ MeV}$$

A proton can convert to a neutron by the process:

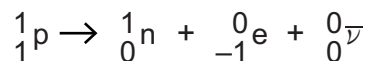

- (i) Show that the minimum energy for this process is about 1.8 MeV.

[2]

- (ii) 1.8 MeV is the activation energy for the conversion of a proton into a neutron. Use the Boltzmann factor to suggest why the ratio of numbers of protons : neutrons rises as the early universe cools, and at a temperature of 10^{11} K it is 1 : 0.812.

.....

 [3]

(c) As the universe cools to 10^{10} K, the proton : neutron ratio continues to rise. Neutrons can be fused to protons forming the simplest compound nucleus of deuterium ${}^2_1\text{H}$.

(i) Show that the binding energy for ${}^2_1\text{H}$ is about 2 MeV.

$$m_{\text{DEUTERON}} = 2.013553 \text{ u}$$

[2]

(ii) Explain why some of the deuterons formed will also break apart at this temperature

.....
..... [1]

END OF QUESTION PAPER

ADDITIONAL ANSWER SPACE

If additional space is required, you should use the following lined page(s). The question number(s) must be clearly shown in the margin(s).

A large rectangular area with a solid vertical line on the left side and horizontal dotted lines across the rest of the page, providing space for writing answers.



Copyright Information

OCR is committed to seeking permission to reproduce all third-party content that it uses in its assessment materials. OCR has attempted to identify and contact all copyright holders whose work is used in this paper. To avoid the issue of disclosure of answer-related information to candidates, all copyright acknowledgements are reproduced in the OCR Copyright Acknowledgements Booklet. This is produced for each series of examinations and is freely available to download from our public website (www.ocr.org.uk) after the live examination series.

If OCR has unwittingly failed to correctly acknowledge or clear any third-party content in this assessment material, OCR will be happy to correct its mistake at the earliest possible opportunity.

For queries or further information please contact the Copyright Team, First Floor, 9 Hills Road, Cambridge CB2 1GE.

OCR is part of the Cambridge Assessment Group; Cambridge Assessment is the brand name of University of Cambridge Local Examinations Syndicate (UCLES), which is itself a department of the University of Cambridge.