

A Level Physics B (Advancing Physics) H557/01 Fundamentals of Physics

Practice paper – Set 1 Time allowed: 2 hours 15 minutes

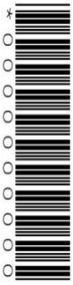

You must have:

- the Data, Formulae and Relationships Booklet

You may use:

- a scientific calculator
- a ruler (cm/mm)

First name										
Last name										
Centre number						Candidate number				

INSTRUCTIONS

- Use black ink. You may use an HB pencil for graphs and diagrams.
- Complete the boxes above with your name, centre number and candidate number.
- Answer **all** the questions.
- Write your answer to each question in the space provided. If additional space is required, use the lined page(s) at the end of this booklet. The question number(s) must be clearly shown.
- Do **not** write in the barcodes.

INFORMATION

- The total mark for this paper is **110**.
- The marks for each question are shown in brackets [].
- This document consists of **36** pages.
- Quality of extended responses will be assessed in questions marked with an asterisk (*).

SECTION A

You should spend a maximum of 40 minutes on this section.

Write your answer for each question in the box provided.

Answer **all** the questions.

1 Which pair contains one vector and one scalar quantity?

- A velocity acceleration
- B distance force
- C kinetic energy power
- D momentum displacement

Your answer

[1]

2 Which one of the following could **not** be used as a unit of stress?

- A Pa
- B N m^{-2}
- C J m^{-3}
- D kg m s^{-2}

Your answer

[1]

3 Which experimental procedure reduces systematic error of the quantity being measured?

- A timing a large number of oscillations to find the period of a pendulum
- B measuring the diameter of a wire several times to find an average
- C adjusting a voltmeter to remove its zero error before measuring a p.d.
- D repeating readings of the activity of a radioactive rock before taking an average

Your answer

[1]

4 Which quantity is followed by a reasonable estimate of its magnitude?

- A wavelength of green light 500 nm
- B frequency of a radio wave 900 GHz
- C mass of a bee 800 μg
- D volume of water for a bath 3000 mm^3

Your answer

[1]

5 A signal is being digitized by sampling at 2.0 kHz.
The total voltage is 3.0 V and the noise voltage is 5.9 mV.

Which statement is **not** correct?

- A $\frac{V_{\text{total}}}{V_{\text{noise}}} \approx 500$
- B The recommended number of bits per sample is 9
- C The highest frequency in the signal should not exceed 1.0 kHz
- D The voltage resolution of the sampling should be less than 3.0 mV

Your answer

[1]

The following information is for use in questions 6 and 7.

Here are some statements about the conduction electrons in a copper wire at room temperature.

- A They are moving freely through the wire.
- B They are moving rapidly and at random making collisions with each other and with the copper ions.
- C They are drifting slowly along the wire making collisions with each other and with the copper ions.
- D They are drifting slowly along the wire but are also moving rapidly and at random, making collisions with each other and with the copper ions.

- 6 Which of the above statements best describes the motion of conduction electrons when there is no current in the wire?

Your answer

[1]

- 7 Which of the above statements best describes the motion of conduction electrons when there is a constant current in the wire?

Your answer

[1]

- 8 Which statement about mechanical properties of materials is **not** correct?

- A Cracks are a common way in which a brittle material can fail mechanically.
- B A material with a high Young modulus will be very stiff.
- C The tensile strength of a stiff material can be relatively small.
- D If a material is tough it will also usually be brittle.

Your answer

[1]

- 9 For the strain of two different stretched wires to be the same they must have the same ratio of
- A stress to Young modulus.
 - B tension to cross-sectional area.
 - C tension to extension.
 - D tension to original length.

Your answer

[1]

- 10 The $V-I$ graphs of two electrical components **K** and **L** are shown below.

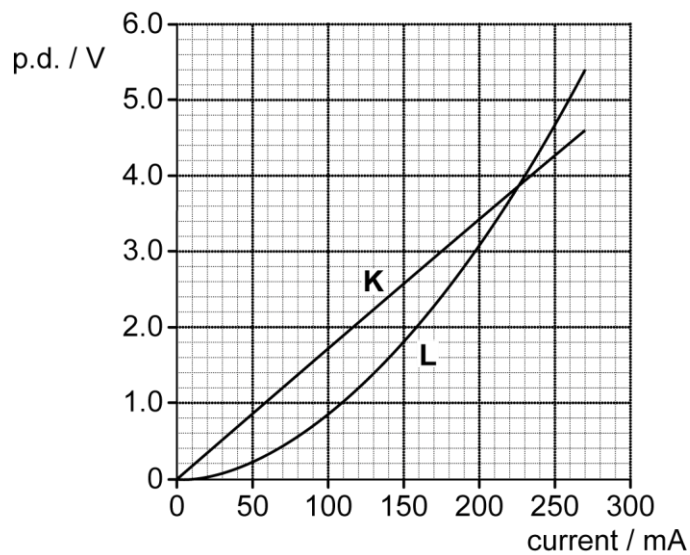

Which statement is **not** correct?

- A **K** is a resistor and **L** is a filament lamp.
- B The resistance of **L** increases as the current in it increases.
- C Up to 3.8 V the conductance of **K** is larger than the conductance of **L**.
- D **K** and **L** have equal resistance where the graphs intersect at 3.8 V.

Your answer

[1]

11 The diagram shows an arrangement of equal resistors.

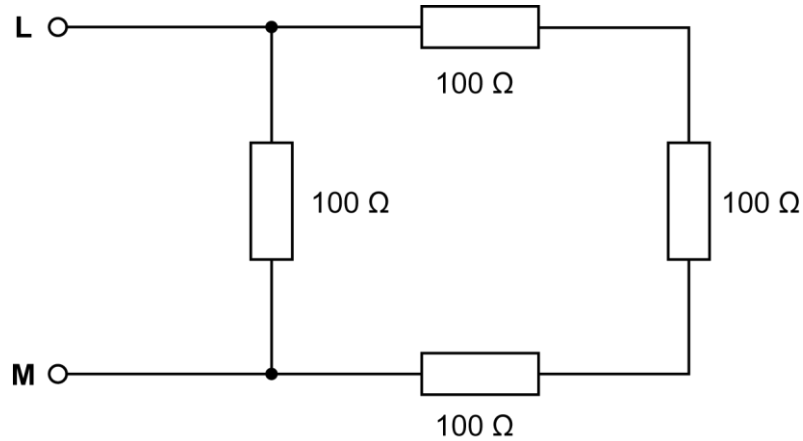

What is the total electrical resistance between **L** and **M**?

- A less than $10\ \Omega$
- B between $10\ \Omega$ and $100\ \Omega$
- C between $100\ \Omega$ and $300\ \Omega$
- D $400\ \Omega$

Your answer

[1]

12 Kirchhoff's two laws for electric circuits can be derived from conservation laws.

On which conservation laws do Kirchhoff's laws depend?

	Kirchoff's first law	Kirchoff's second law
A	mass	energy
B	current	mass
C	charge	energy
D	energy	current

Your answer

[1]

- 13 A long thick length **P** of tungsten wire is connected in series with a shorter thinner length **Q** of tungsten wire to a variable power supply. The current I in them is adjusted so that when heated by the current their resistances become equal. The wires are not equally hot, **P** is just warm while **Q** glows red.

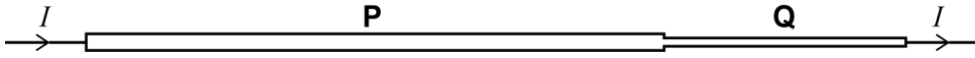

Which of the following statements about this experiment is/are correct?

- 1 The potential difference across each wire is the same.
 - 2 The power dissipated in **P** > power dissipated in **Q**.
 - 3 When the current is switched off and the wires have returned to room temperature, the resistances of **P** and **Q** remain equal.
- A** 1, 2 and 3 are correct
B only 1 and 2 are correct
C only 2 and 3 are correct
D only 1 is correct

Your answer

[1]

Question 14 begins on page 8

- 14 The graph shows how the length of a perspex strip varies with tension force F . The strip has a cross-sectional area of 4 mm^2 when it breaks at **Q**.

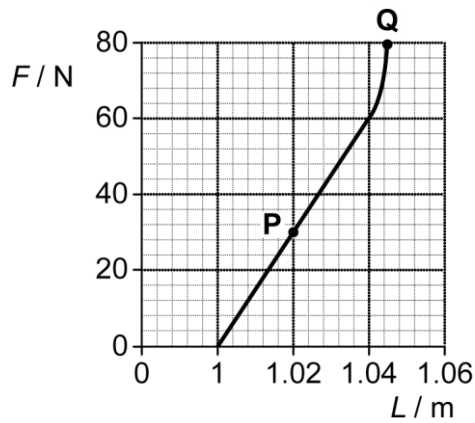

Which of the following statements agree with this data?

- 1 The strain at **P** is 2%.
- 2 The breaking stress is $20 \times 10^6 \text{ Pa}$.
- 3 Hooke's law is obeyed up to a strain of 0.04.

- A** 1, 2 and 3 are correct
B only 1 and 2 are correct
C only 2 and 3 are correct
D only 1 is correct

Your answer

[1]

- 15 Suppose a certain atom has only four possible energy levels.

What would be the maximum number of different energies of photons that it could emit?

- A** 3
B 4
C 6
D 8

Your answer

[1]

- 16** Laser light is passed through a single slit onto a distant screen.
The graph illustrates the variation of intensity with position on the screen.

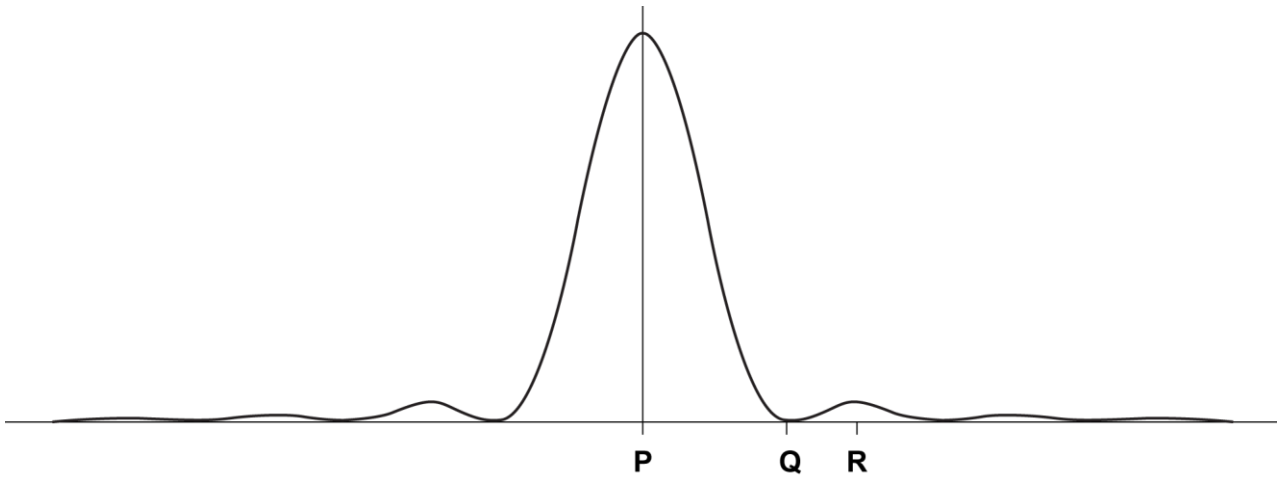

Which of the following statements about the positions **P**, **Q** and **R** on the screen is/are correct?

- 1** At **P** all the phasors from different positions across the slit line up to give a large resultant.
 - 2** At **Q** phasors from different positions across the slit curl up to give zero resultant.
 - 3** At **R** the probability of arrival of a photon will increase if the slit is made a little narrower.
- A** 1, 2 and 3 are correct
- B** only 1 and 2 are correct
- C** only 2 and 3 are correct
- D** only 1 is correct

Your answer

[1]

- 17 A ball is released from rest above a horizontal surface and bounces. The graph shows how the velocity of the ball varies with time.

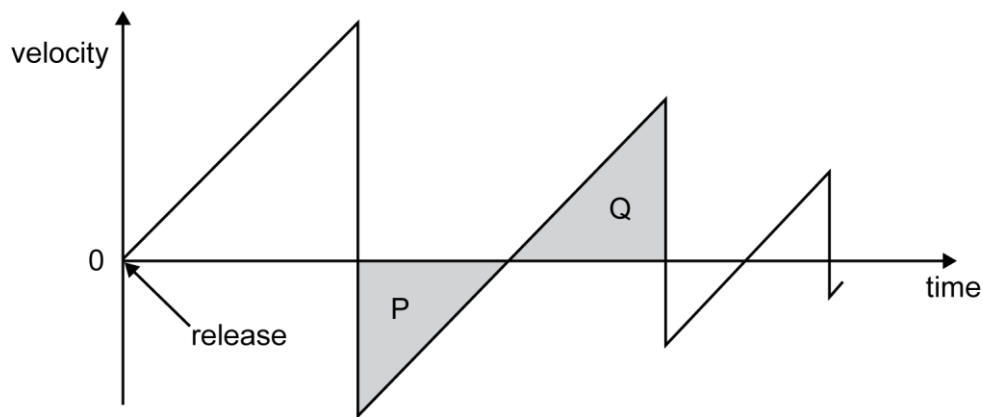

Which statement best explains why areas **P** and **Q** equal?

- A The ball's acceleration is constant between bounces.
- B At each bounce the ball loses a fraction of its kinetic energy.
- C The ball rises and falls through the same distance between bounces.
- D After a bounce the ball leaves the surface with the same speed at which it hits the surface for the next bounce.

Your answer

[1]

- 18 Here is a list of oscillators.

- 1 infrared radiation
- 2 mains voltage
- 3 a simple pendulum 1 metre long

Which of the following sequences correctly places them in order of increasing frequency?

- A 2 1 3
- B 2 3 1
- C 3 1 2
- D 3 2 1

Your answer

[1]

The following information is for use in questions 19 and 20.

The graphs **A** to **D** may plot energy against displacement for a harmonic oscillator. The oscillator vibrates in a straight line with amplitude X .

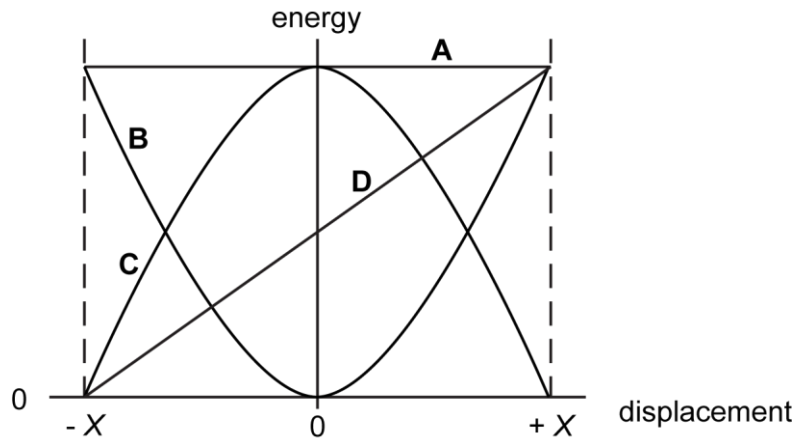

19 Which graph represents the total energy of the harmonic oscillator?

Your answer

[1]

20 Which graph represents the kinetic energy of the harmonic oscillator?

Your answer

[1]

21 Which of the following statements about electromagnetic waves is/are correct?

- 1 It is reasonable to infer that both γ -rays and radio waves are electromagnetic because they both carry energy.
- 2 It is reasonable to expect to be able to polarise electromagnetic waves because they are transverse.
- 3 It is reasonable to expect to observe diffraction of electromagnetic waves of frequency 2×10^8 Hz by an object 1.5 m in diameter since electromagnetic waves travel at 3×10^8 m s⁻¹.

- A** 1, 2 and 3 are correct
- B** only 1 and 2 are correct
- C** only 2 and 3 are correct
- D** only 1 is correct

Your answer

[1]

The following information is for use in questions 22 and 23.

Bass speakers can be mounted in a box to act as a resonator at natural frequency f . The box has a volume V and an aperture of area A cut into its front as shown.

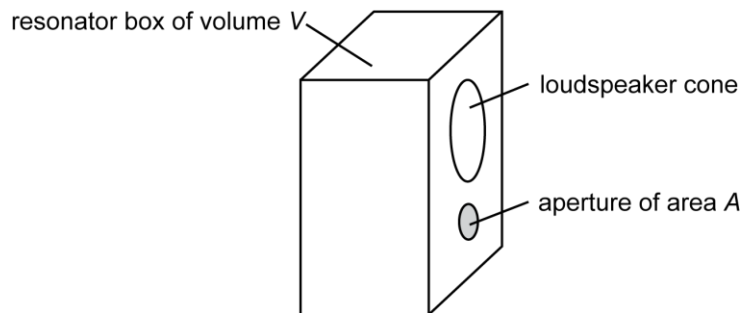

The resonator frequency f is given by $f^2 = \frac{kA}{V}$ where k is a constant.

The designer wants to make the aperture a circle of radius r .

22 How does the volume V vary with r when the resonant frequency f is kept constant?

- A** V is proportional to $\frac{1}{r}$
- B** V is proportional to r^2
- C** V is proportional to $r^{1/2}$
- D** V is proportional to r

Your answer

[1]

23 How does the resonant frequency f vary with r when the volume V is kept constant?

- A** f is proportional to $\frac{1}{r}$
- B** f is proportional to r^2
- C** f is proportional to $r^{1/2}$
- D** f is proportional to r

Your answer

[1]

24 The decay of a nucleus of strontium-90 is shown by the equation

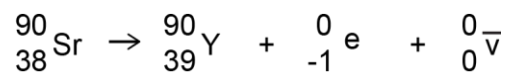

What happens to the total charge number, nucleon number and lepton number as a result of this decay?

	charge number	nucleon number	lepton number
A	decreases	conserved	increases
B	conserved	conserved	conserved
C	conserved	conserved	decreases
D	increases	decreases	conserved

Your answer

[1]

Question 25 begins on page 14

The following information is for use in questions 25 and 26.

Two radioactive sources of equal mass are freshly prepared.

One is a β emitter ^{225}Ra with a half-life of 15 days.

The other is an α emitter ^{225}Ac with a half-life of 10 days.

25 After 30 days, which one of **A** to **D** below gives the ratio: $\frac{\text{number of } ^{225}\text{Ra atoms}}{\text{number of } ^{225}\text{Ac atoms}}$?

A 2.0

B 1.33

C 1.0

D 0.5

Your answer

[1]

26 After 30 days, which one of **A** to **D** below gives the ratio: $\frac{\text{activity of } ^{225}\text{Ra atoms}}{\text{activity of } ^{225}\text{Ac atoms}}$?

A 2.0

B 1.33

C 1.0

D 0.5

Your answer

[1]

- 27 The diagram shows a charged oil drop between two parallel plates connected to a high **constant** voltage V .

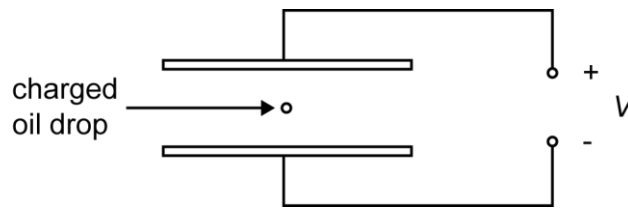

Which of the following correctly describe(s) changes to the electrical force on the drop?

- 1 If the plates were closer together, the electrical force on the drop would be larger.
 - 2 If the drop acquires more charge the electrical force on it increases.
 - 3 If the drop moves nearer to the top plate the electrical force on it increases.
- A 1, 2 and 3 are correct
 B only 1 and 2 are correct
 C only 2 and 3 are correct
 D only 1 is correct

Your answer

[1]

- 28 The differently charged ions of several isotopes are all fired at the same speed. They pass into a region of uniform magnetic flux density perpendicular to their path.

Which of the ions **A** to **D** will travel in the circular path of **smallest** radius?

- A ${}^6_3\text{Li}^+$
 B ${}^6_3\text{Li}^{2+}$
 C ${}^{12}_6\text{C}^{2+}$
 D ${}^{14}_6\text{C}^{4+}$

Your answer

[1]

29 Which of the following three values is/are required to calculate the speed v of a satellite of mass m in a circular orbit of radius r around the Earth?

- 1 the mass m of the satellite
- 2 the radius r of the orbit
- 3 GM (the gravitational constant G x M the mass of the Earth)

- A 1, 2 and 3 are correct
- B only 1 and 2 are correct
- C only 2 and 3 are correct
- D only 1 is correct

Your answer

[1]

30 An asteroid moves around the Sun in an ellipse, as shown. It is closest to the Sun at **X** and furthest from the Sun at **Y**.

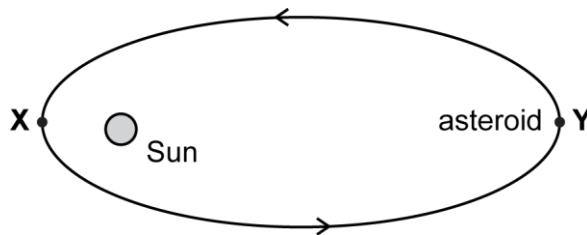

Which one of the following quantities is greater at **Y** than at **X**?

- A the gravitational force on the asteroid due to the Sun
- B the kinetic energy of the asteroid
- C the speed of the asteroid in its orbit
- D the gravitational potential energy of the Sun-asteroid system

Your answer

[1]

SECTION B

Answer **all** the questions.

31 Fig. 31.1 shows the $V-I$ graph for a potato cell (copper and zinc electrodes stuck in a potato shown in Fig. 31.2).

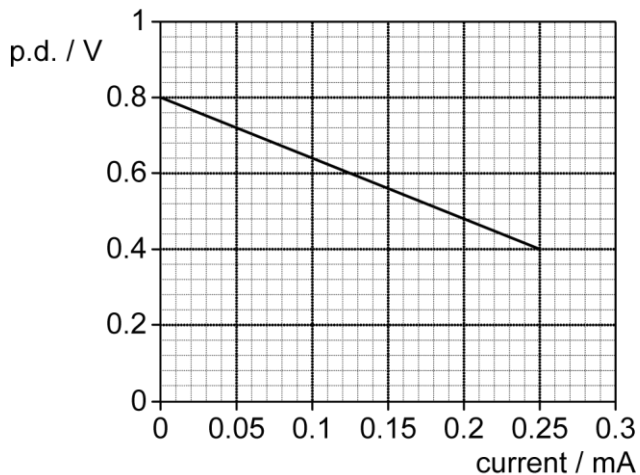

Fig. 31.1

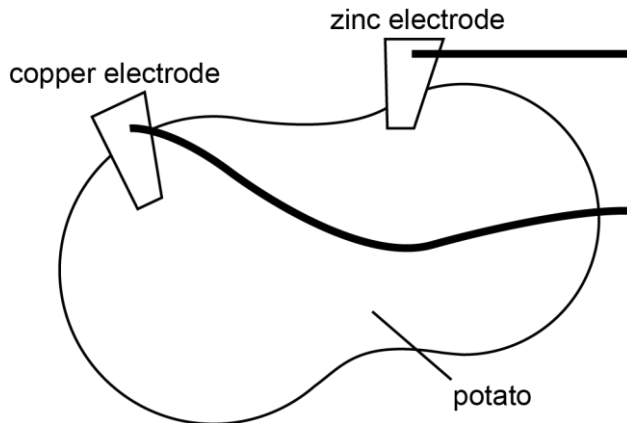

Fig. 31.2

(a) Use Fig. 31.1 to identify the internal resistance of the potato cell. Make your method clear.

internal resistance = Ω [2]

(b) (i) On Fig. 31.1 draw the $V-I$ graph for a constant resistor of resistance $10\text{ k}\Omega$. [1]

(ii) Using the graph drawn state and explain the current through the $10\text{ k}\Omega$ external resistor when connected across the potato cell.

current = mA

.....

 [2]

32 Fig. 32.1 shows histograms for a raw image and its processed version. The histogram plots the number of pixels against pixel value (0 to 255) for each image.

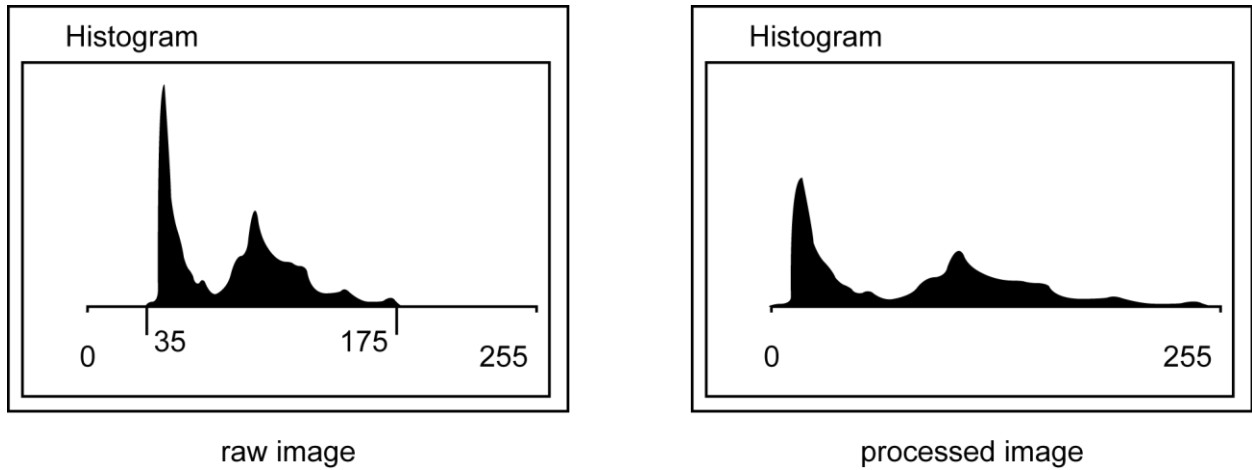

Fig. 32.1

(a) State and describe the process that has been applied to improve the image.

.....

 [2]

(b) Complete the equation below for calculating the new pixel (grayscale) value from the old value to achieve this image enhancement.

new pixel value = (old pixel value – 35) x (.....) / (.....) [1]

33 A teacher uses a portable radio to demonstrate some properties of waves. She tunes in to a VHF station.

(a) She obtains the strongest signal when the aerial is vertical as shown below.

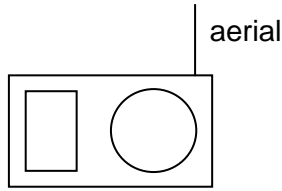

However the signal fades to a minimum when she rotates the radio through 90° as shown below.

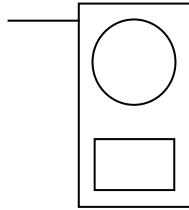

State the property of transverse waves that this experiment demonstrates.

.....[1]

(b) The teacher rotates the radio once more through another 90°, as shown below.

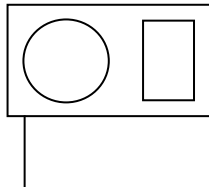

State and explain the effect this has on the strength of the received signal.

.....

[2]

34 The equation for the energy stored in a capacitor is $E = \frac{1}{2} Q V$.
Q is the charge on the capacitor at potential difference V across it.

(a) State the reason for the factor of $\frac{1}{2}$ in the equation.

.....
.....
..... [1]

(b) A 500 μF capacitor delivers 200J of energy when discharged through a resistor.

Calculate the p.d. across the capacitor before the discharge.

p.d. = V [2]

Question 35 begins on page 21

- 35 In still water a boat can travel at 6.0 m s^{-1} . A river flows steadily at 2.0 m s^{-1} . The boat must cross the river perpendicular to the banks as shown in Fig. 35.1.

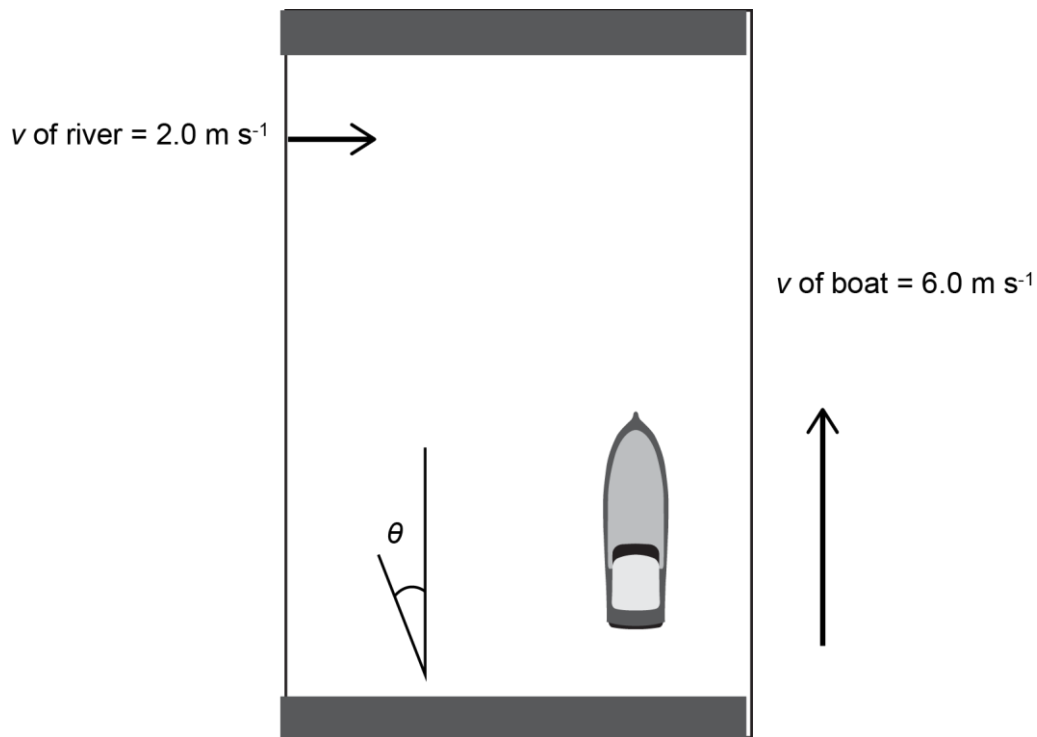

Fig 35.1

- (a) Calculate the angle θ at which the boat should be steered to cross perpendicular to the banks.
Make your method clear.

$$\theta = \dots\dots\dots^\circ \text{ [2]}$$

- (b) Calculate the magnitude of the velocity perpendicular to the banks.

$$\text{magnitude of perpendicular velocity} = \dots\dots\dots \text{ m s}^{-1} \text{ [1]}$$

36 Fig. 36.1 and Fig. 36.2 show space-time diagrams for radar ranging of two objects. Lines representing the paths of objects through space and time are called worldlines.

The y -axes are in μs and the x -axes in light μs as shown. We are stationary in our frame of reference, travelling only in time and not in space, therefore represented by a vertical worldline from the origin.

Fig. 36.1 shows an object not moving relative to our frame, with another vertical worldline.

Fig. 36.2 shows an object moving relative to our frame through space and time.

The objects are at the same distance when radar pulses are reflected.

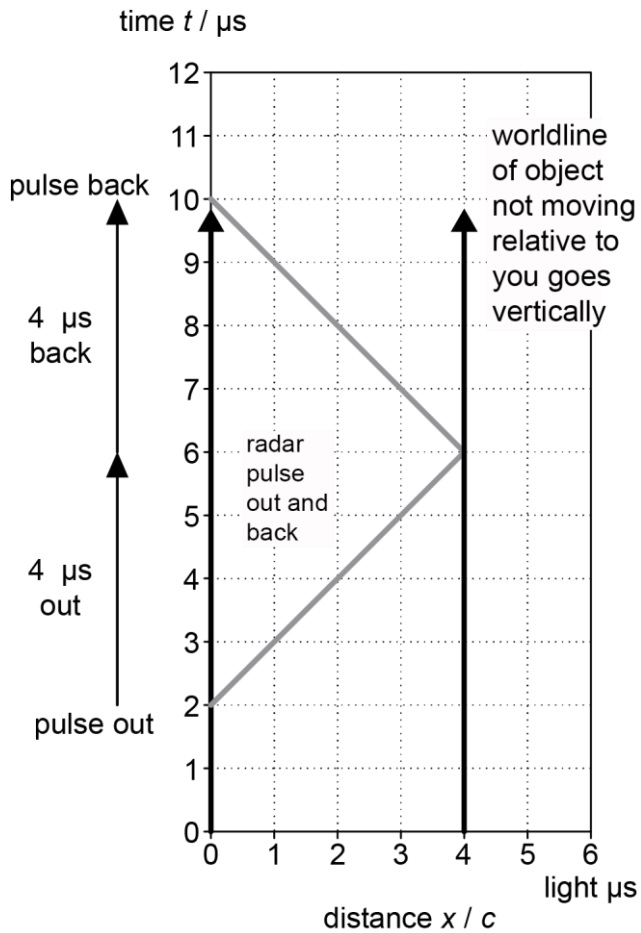

Fig. 36.1

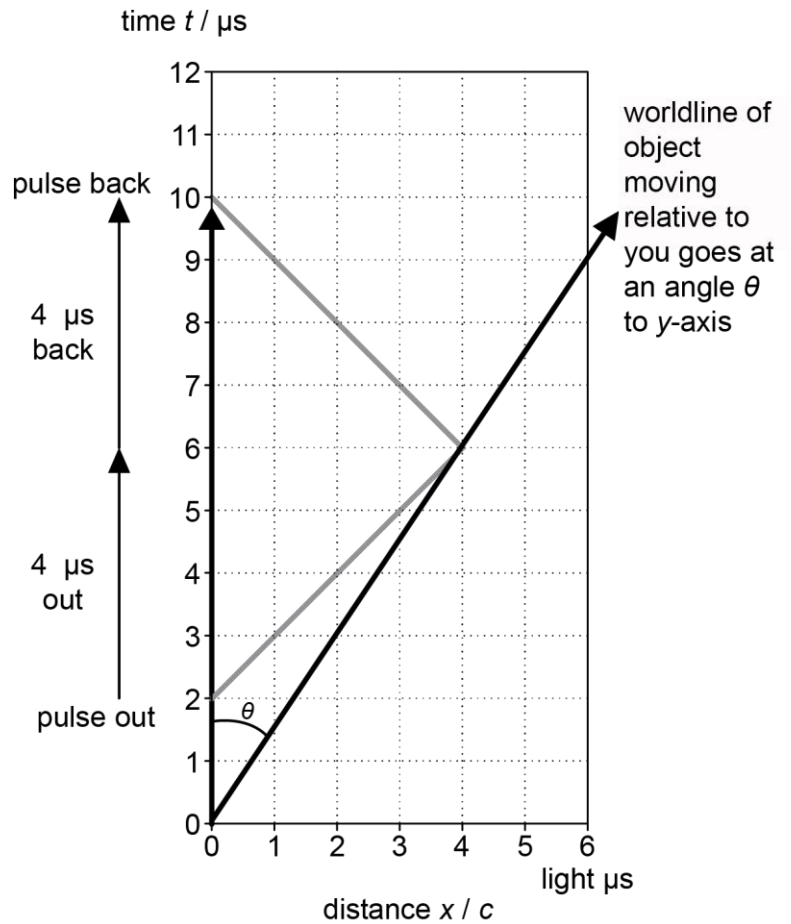

Fig. 36.2

(a) Calculate the range of the objects when the radar pulse is reflected.

range = m [1]

- (b) (i) State why radar pulses on this diagram travel at 45° across the diagram.

..... [1]

- (ii) Show that speed of moving object in **Fig. 36.2** is given by $\tan \theta$. Calculate this speed.

speed = m s^{-1} [2]

- (c) On **Fig. 36.1** and **Fig. 36.2** draw on the radar pulses emitted at $t = 3.0 \mu\text{s}$ and their reflections. [2]

Section C begins on page 24

SECTION C

Answer **all** the questions

- 37** This question is about modelling projectile motion using iteration in discrete time intervals Δt . Here $\Delta t = 0.1$ s and g is taken as 10 m s^{-2} . The first data row sets up initial conditions. Then the rules in the column headings are applied using data from the previous row. An analytical solution to the motion is also shown using kinematic equations.

iterative numerical solution				analytical solution
time lapsed t / s $t_{\text{new}} = t_{\text{old}} + \Delta t$	x displacement / m at constant v_x $x_{\text{new}} = x_{\text{old}} + v_x \Delta t$	$v_y / \text{m s}^{-1}$ $v_{\text{new}} \approx v_{\text{old}} - g \Delta t$	y displacement / m $y_{\text{new}} \approx y_{\text{old}} + v_y \Delta t$	$y = ut - \frac{1}{2}gt^2 / \text{m}$
0	0	4.0	0	0
0.1	$0 + (3 \times 0.1)$ = 0.3	$4 - (10 \times 0.1)$ = 3	$0 + (4 \times 0.1)$ = 0.4	$4 \times 0.1 - (5 \times 0.1^2)$ = 0.35
0.2	$0.3 + (3 \times 0.1)$ = 0.6	$3 - (10 \times 0.1)$ = 2	$0.4 + (3 \times 0.1)$ = 0.7	$4 \times 0.2 - (5 \times 0.2^2)$ = 0.6
0.3	$0.6 + (3 \times 0.1)$ = 0.9	$2 - (10 \times 0.1)$ = 1	$0.7 + (2 \times 0.1)$ = 0.9	$4 \times 0.3 - (5 \times 0.3^2)$ = 0.75
0.4	= 1.2	= 0		
0.5	= 1.5	= -1		
0.6	= 1.8	= -2	= 0.9	= 0.6
0.7	= 2.1	= -3	= 0.7	= 0.35
0.8	= 2.4	= -4	= 0.4	= 0

(a) Air resistance effects have been ignored in these models.

- (i) State how you recognize this for the v_y column.

.....
 [1]

- (ii) State why there is a systematic difference between the y displacements in the iterative and analytical models.

.....
 [1]

- (iii) State how the size of this systematic error can be controlled.

.....
 [1]

(iv) State why there is no systematic error in the x displacement column.

.....
 [1]

(b) Complete the table by writing in the missing numerical values. [2]

(c) Fig. 37.1 shows parts of the (x, y) trajectory predicted by the models.

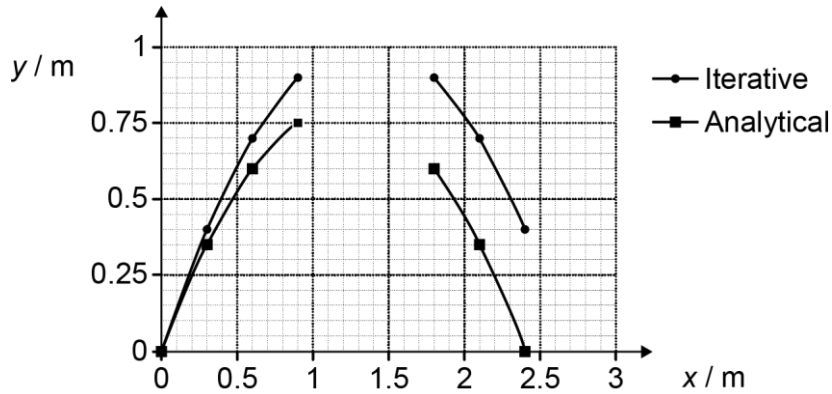

Fig. 37.1

(i) Add the missing data points you calculated in (b) to Fig. 37.1 and complete the two graphs. [2]

(ii) State **one** similarity and **one** difference in the predictions of the two models.

similarity:

difference:

[2]

(d) Explain why scientists use approximate iterative models when analytical ones seem to give a better solution.

.....

 [2]

38 This question considers how ideas about light have developed over time. Huygens thought that each point on a light wavefront emitted secondary wavelets. **Fig. 38.1** shows five secondary wavelets emitted from the original wavefront OO' . These wavelets add together a short time later to find the new position of the wavefront AA' .

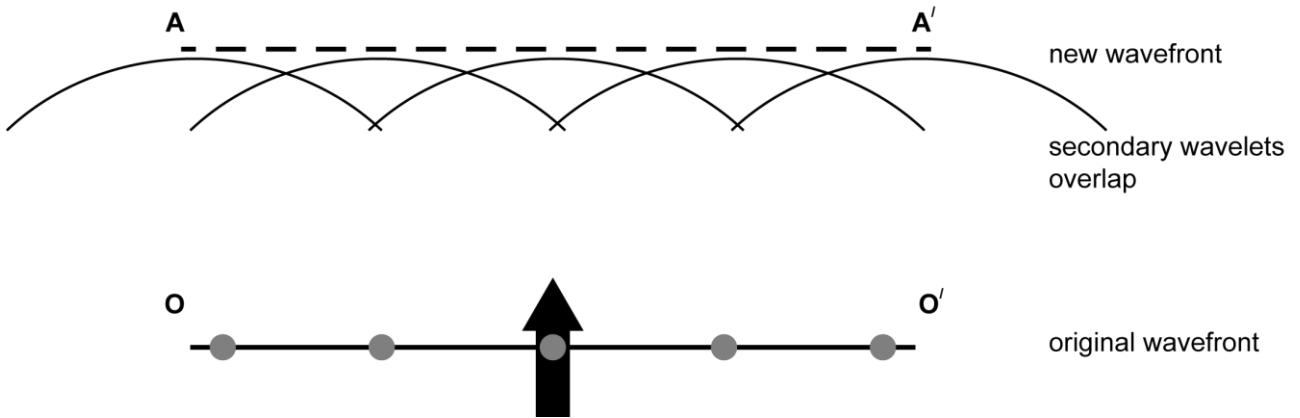

Fig 38.1

(a) (i) State and explain the principle of wave behaviour that is equivalent to *adding secondary wavelets*.

.....

 [2]

(ii) State a phenomenon that supports Huygen’s idea of secondary wavelets.

.....

 [1]

(iii) Huygens knew that light does not have infinite speed and requires time to travel. Suggest the feature of **Fig. 38.1** that supports this.

.....

 [1]

- (b) Huygens did not have access to diffraction gratings, but his ideas can help us to understand how they work. **Fig. 38.2** shows a plane wave passing through part of a grating consisting of five slits.

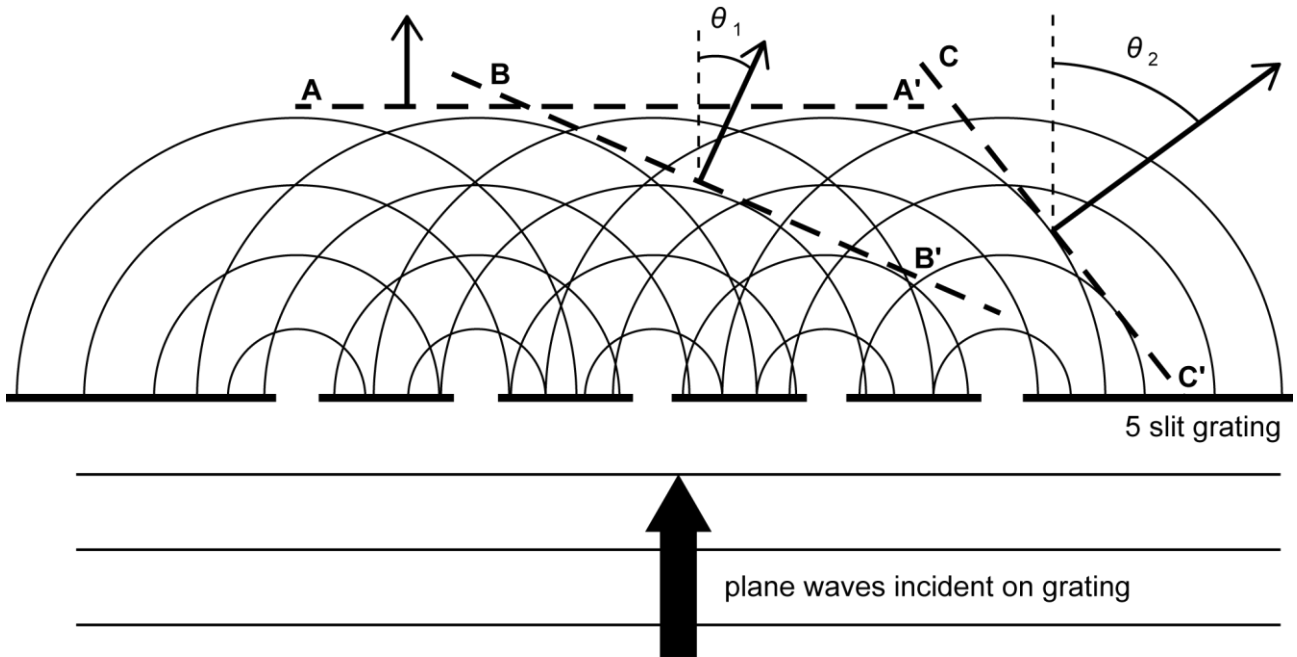

Fig. 38.2

The construction lines **AA'**, **BB'** and **CC'**, drawn on Fig. 38.2, represent some of the plane wavefronts that travel away from the grating at angles θ to the incident direction.

- (i) Suggest how Huygens might explain that the amplitude of the resultant waves along the wavefront **BB'** is particularly large.

.....
 [1]

- (ii)* For the grating shown in the diagram: $\frac{\text{wavelength, } \lambda}{\text{grating spacing, } d} = 0.40$ $\theta_1 = 24^\circ$ $\theta_2 = 53^\circ$.

Explain the values of these angles and how the diffraction grating works using modern wave **and** photon phasor models.

.....

 [6]

39 A student investigates how the resistance of an LDR varies with light intensity using a lux-meter and an ohm-meter capable of $\pm 1\%$ uncertainty. The teacher also advises her to calculate the conductance G of the LDR, and to plot the graphs shown below. **Fig. 39.1**, **Fig. 39.2** and **Fig. 39.3** show her incomplete practical results.

Light Intensity / lux	R_{LDR} / Ω	G / mS
15	13000	0.08
70	3450	0.29
150	1640	0.61
260	1070	0.93
500	530	
1000	270	
1500	186	
2000	150	

Fig. 39.1

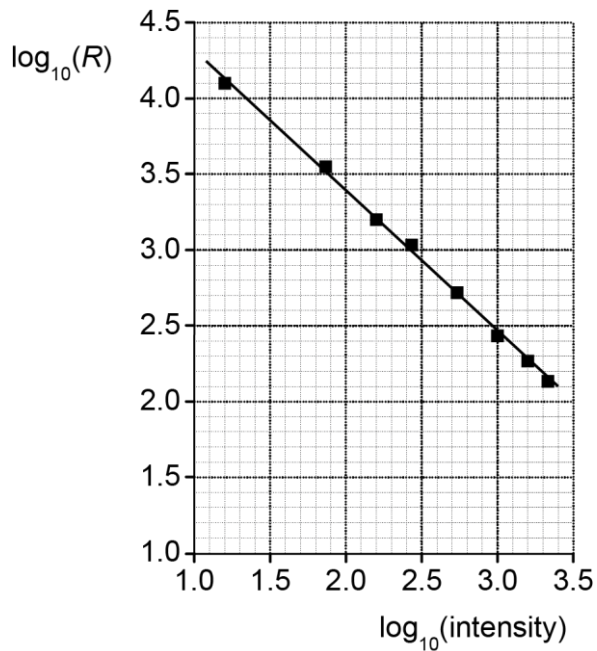

Fig. 39.2

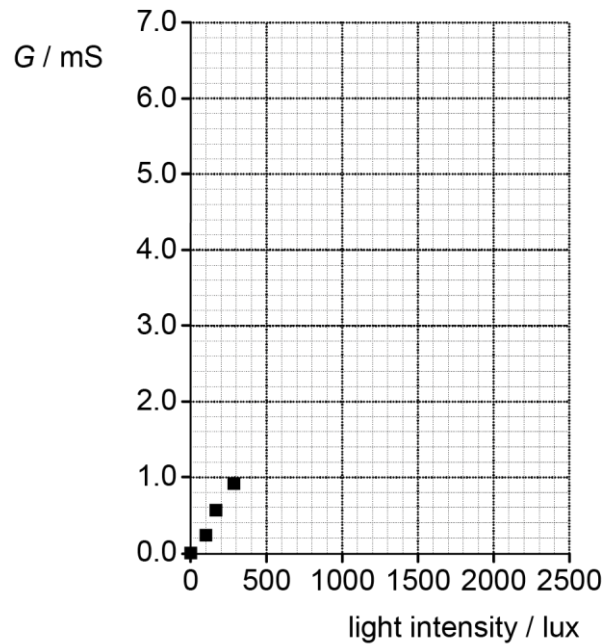

Fig. 39.3

(a) (i) Complete her table **Fig. 39.1** for conductance G in mS. Plot the remaining data on her graph of **Fig. 39.3** and draw a line of best fit. [3]

(ii) Explain why these graphs are more useful than a plot of R against light intensity, and state your conclusion about what they show.

.....

.....

.....

..... [3]

- (iii) The light sensitive material in the LDR is a semiconductor. It is suggested that the charge carrier density in the material is proportional to the light intensity shining on it.

Give a reason for this suggestion and evaluate it using the graphical evidence from part (i).

.....

.....

.....

.....

..... [2]

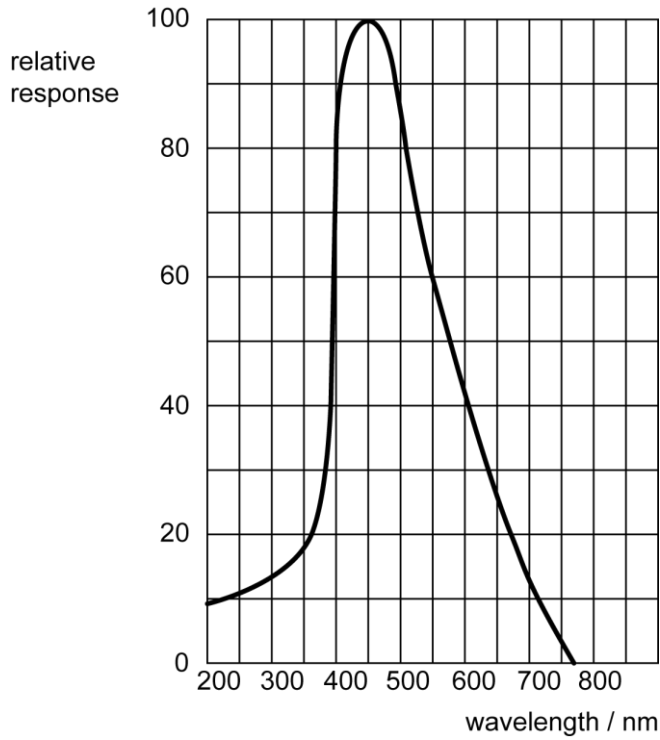

- (i) State the feature of the graph that suggests a quantum process might be involved in changing charge carrier density when the LDR is illuminated.

.....

.....

..... [1]

- (ii) Use a value from the graph to calculate the minimum energy for the quantum process.

energy = J [2]

- (c) The LDR is set up in the potential divider circuit as shown with a 6.0 V supply and a fixed resistor of resistance 470Ω .

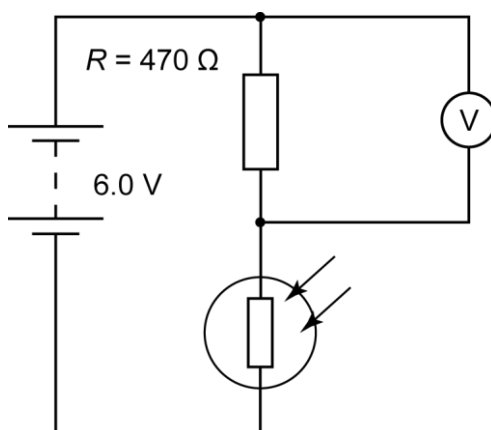

Use data in **Fig. 39.1** to calculate the p.d. measured by the voltmeter when the light intensity is 1000 lux.

p.d. = V [2]

Question 40 starts on page 31

40 (a) Fig. 40.1 shows the gravitational potential V_g of the Earth from the surface out to 200 Mm. r is the distance measured from the centre of the Earth.

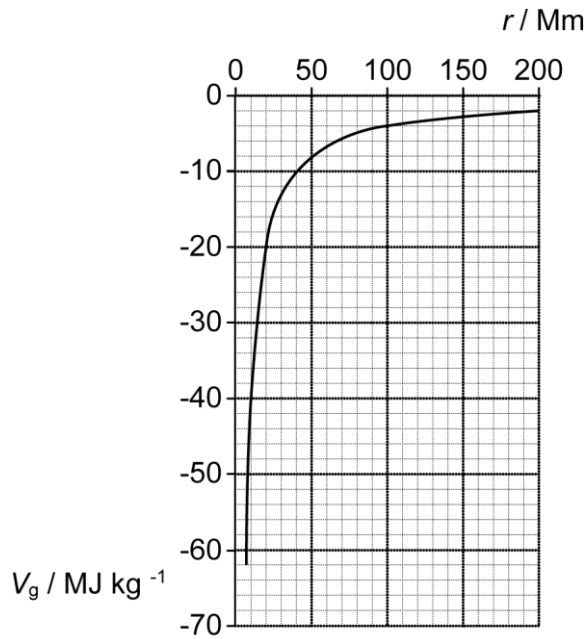

Fig. 40.1

(i) State why the potential is plotted as a negative value.

.....
 [1]

(ii) Calculate the launch velocity that is needed for a spacecraft to escape Earth's gravity. Use data from the graph and make your method clear. You can ignore the effects of air drag.

velocity =m s⁻¹ [2]

(b) (i) Show that the general equation for escape velocity is:

$$V_{\text{escape}} = \sqrt{\frac{2GM}{r}}$$

Make clear what the symbols M , G and r mean.

[3]

- (ii) For a spherical body of constant fixed density ρ and radius R show that the escape velocity v_{escape} can be calculated from the equation :

$$v_{\text{escape}} = \sqrt{\frac{8 G \pi \rho}{3}} R$$

.....
 [1]

- (iii) A neutron star has a density $\rho \approx 10^{17} \text{ kg m}^{-3}$. When $v_{\text{escape}} = c$ it will become a black hole.

Estimate the radius of the neutron star when it has an escape velocity of $c = 3 \times 10^8 \text{ m s}^{-1}$.

radius = m [2]

- 41 Radon decays by α -decay into polonium ${}_{84}^{218}\text{Po}$.

The α -particle in this decay always has kinetic energy of 5.5 MeV.

The table shows the precise masses of these nuclei in atomic mass units / u.

$$1 \text{ u} = 1.661 \times 10^{-27} \text{ kg}$$

nucleus	nuclear mass / u
Radon 222	221.9703
Polonium 218	217.9628
Helium (α) 4	4.0015

- (a)* Show that in this process the mass of the products is less than the mass of the original nucleus. Explain the term *binding energy* and show that the binding energy released is greater than the 5.5 MeV of the α -particle. Use ideas about forces and momenta during the α -decay to suggest why the α -particle does not take away all the energy from the decay.

[6]

- (b) This part considers some algebraic reasoning to help to account for the difference between the energy of the α -particle and the binding energy released in (a).

(i)
$$m_{\alpha} v_{\alpha} = m_{\text{Po}} v_{\text{Po}} \rightarrow \frac{v_{\text{Po}}}{v_{\alpha}} = \frac{m_{\alpha}}{m_{\text{Po}}}$$

Where: m_{α} = mass of α -particle, m_{Po} = mass of polonium nucleus,
 v_{α} = velocity of α -particle v_{Po} = velocity of polonium nucleus.

State the physics principle used in this algebraic reasoning.[1]

- (ii) Use (i) to show that the ratio of
 kinetic energy of the polonium nucleus

 kinetic energy of the α -particle

is given by:

$$\frac{\frac{1}{2} m_{\text{Po}} v_{\text{Po}}^2}{\frac{1}{2} m_{\alpha} v_{\alpha}^2} = \frac{m_{\alpha}}{m_{\text{Po}}}$$

[1]

(iii) The fraction of total kinetic energy taken by α -particle = $\frac{1}{(1 + m_\alpha / m_{Po})}$

Use the equations above to calculate the kinetic energy of the α -particle and comment on the value.

kinetic energy of α particle = MeV

.....
..... [3]

END OF QUESTION PAPER

PLEASE DO NOT WRITE ON THIS PAGE

OCR
Oxford Cambridge and RSA

Copyright Information:

OCR is committed to seeking permission to reproduce all third-party content that it uses in its assessment materials. OCR has attempted to identify and contact all copyright holders whose work is used in this paper. To avoid the issue of disclosure of answer-related information to candidates, all copyright acknowledgements are reproduced in the OCR Copyright Acknowledgements Booklet. This is produced for each series of examinations and is freely available to download from our public website (www.ocr.org.uk) after the live examination series.

If OCR has unwittingly failed to correctly acknowledge or clear any third-party content in this assessment material OCR will be happy to correct its mistake at the earliest possible opportunity.

For queries or further information please contact the Copyright Team, First Floor, 9 Hills Road, Cambridge CB2 1GE.

OCR is part of the Cambridge Assessment Group. Cambridge Assessment is the brand name of University of Cambridge Local Examinations Syndicate (UCLES), which is itself a department of the University of Cambridge.