

A Level Physics B (Advancing Physics)
H557/01 Fundamentals of physics
Sample Question Paper

Date – Morning/Afternoon

Time allowed: 2 hours 15 minutes



You must have:

- the Data, Formulae and Relationships Booklet

You may use:

- a scientific calculator



First name											
Last name											
Centre number							Candidate number				

INSTRUCTIONS

- Use black ink. You may use an HB pencil for graphs and diagrams.
- Complete the boxes above with your name, centre number and candidate number.
- Answer **all** the questions.
- Write your answer to each question in the space provided.
- Additional paper may be used if required but you must clearly show your candidate number, centre number and question number(s).
- Do **not** write in the bar codes.

INFORMATION

- The total mark for this paper is **110**.
- The marks for each question are shown in brackets [].
- Quality of extended responses will be assessed in questions marked with an asterisk (*).
- This document consists of **32** pages.

SECTION A

You should spend a maximum of 40 minutes on this section.

Answer **all** the questions.

- 1 The isotope of radon ${}_{86}^{220}\text{Rn}$ decays by a series of transformations to a final stable product. The particles emitted during the transformations are α , α , β , β , α .

Which of the isotopes below is the final product of the decay series?

- A ${}_{82}^{206}\text{Pb}$
B ${}_{82}^{207}\text{Pb}$
C ${}_{82}^{208}\text{Pb}$
D ${}_{84}^{212}\text{Po}$

Your answer

[1]

- 2 An imagined atom can exist in five energy levels. Transitions between all levels are possible.

Which statement about the imagined atom is correct?

- A When the atom jumps to a lower level an electron gains energy.
B When the atom emits a photon the atom jumps to a higher energy level.
C There will be six frequencies in the line spectrum of the atom.
D There will be ten frequencies in the line spectrum of the atom.

Your answer

[1]

- 3 A proton is accelerated until its total energy is double its rest energy.

What is its speed, expressed in terms of the speed of light, c ?

- A $0.25c$
B $0.50c$
C $0.75c$
D $0.87c$

Your answer

[1]

- 4 A ray of light passes from air into a rectangular glass block.

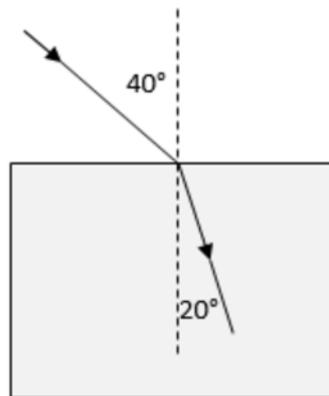

The refractive index of the glass is

- A 0.53
B 0.82
C 1.2
D 1.9

Your answer

[1]

- 5 The solid line shows the standing wave pattern of a vibrating string which is fixed at ends X and Y. The broken line shows the position of the string half a cycle later. The displacement at point Q is a maximum.

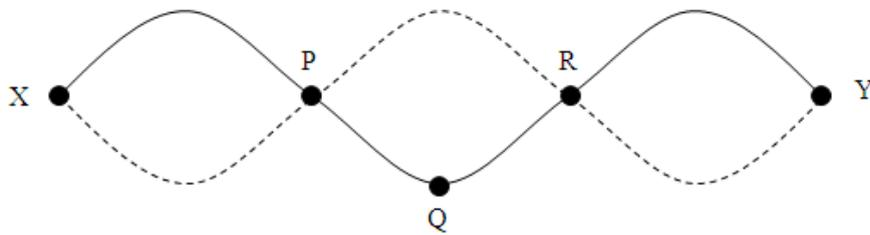

Which one of these statements is true?

- A The distance from P to R is one wavelength.
- B A short time later, the string at R will move up.
- C The lowest possible frequency for this string is one third of its current value.
- D The kinetic energy of the string has its maximum value.

Your answer

[1]

- 6 This is a force–extension graph for two different materials, X and Y. The materials are stretched up to the point at which they fracture.

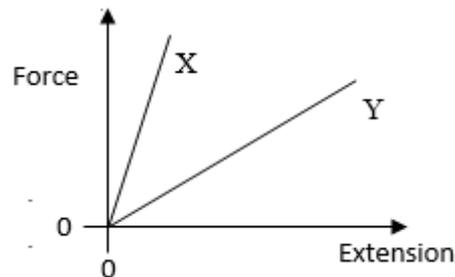

Which one of these statements about the materials is true?

- A Y is stiffer than X
- B both materials are tough
- C X stores more energy than Y
- D X and Y obey Hooke's law

Your answer

[1]

- 7 Source **A** is a radioisotope with a half-life of 2 hours. Source **B** is a radioisotope with a half-life of 4 hours.
The initial activity of source **A** is twice that of source **B**.

How long will pass before the activity of source **B** is twice that of source **A**?

- A** 4 hours
- B** 6 hours
- C** 8 hours
- D** 12 hours

Your answer

[1]

- 8 Here is the equation for beta decay:

- 1 number of quarks
- 2 lepton number
- 3 charge number

- A** 1, 2 and 3
- B** Only 1 and 2
- C** Only 2 and 3
- D** Only 1

Your answer

[1]

- 9 The diagrams 1, 2 and 3 show three different lenses forming images. In each diagram, the dotted lines are equally-spaced and separated by the same distance x .

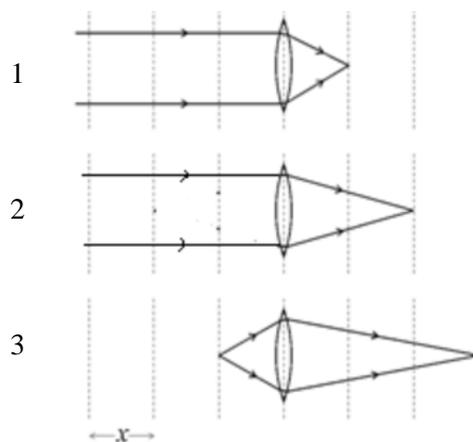

Which, if any, of the lenses have power $P = \frac{1}{x}$?

- A** None
B lens 1
C lens 2
D lens 3

Your answer

[1]

- 10 The graph shows the variation of length L of a spring with the stretching force F .

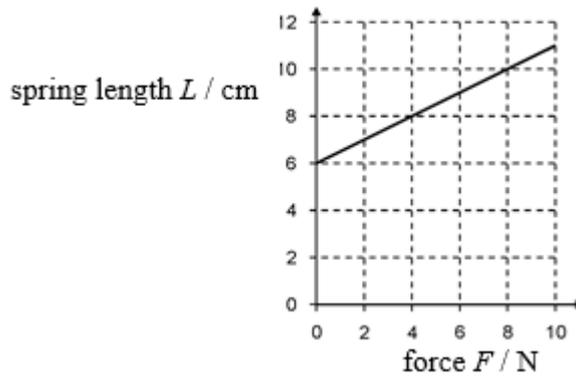

Which is the best estimate of the work done in stretching the spring over the range given by the graph?

- A 0.25 J
- B 0.85 J
- C 85 J
- D 200 J

Your answer

[1]

- 11** The diagram shows two blocks of different masses resting on a smooth surface. They are held together so that a spring between them is in compression.

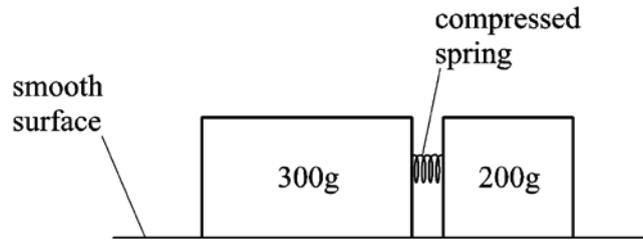

The blocks are released, and the spring pushes them apart.
The maximum speed of the 200 g mass is 4.2 m s^{-1} .

What is the maximum speed of the 300 g mass?

- A** 6.3 m s^{-1}
- B** 2.1 m s^{-1}
- C** 2.8 m s^{-1}
- D** 1.4 m s^{-1}

Your answer

[1]

The following information is for use in questions 12 and 13.

The graphs A–D represent different relationships between variables. The dotted lines mark out equal intervals along the x - and y -axes.

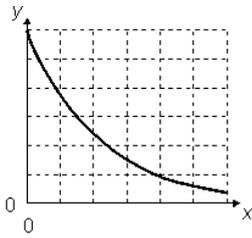
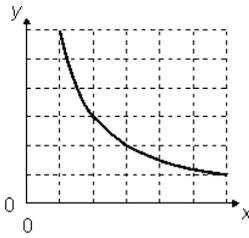
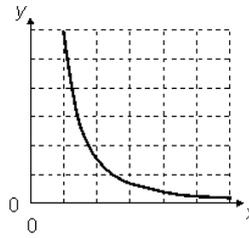
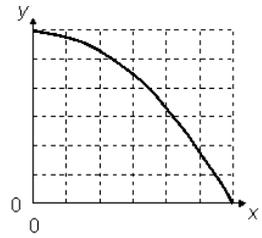
**A****B****C****D**

- 12 Which graph **A**, **B**, **C**, or **D** best represents the relationship between the variables x and y where:

y is the pressure of a fixed mass of gas at room temperature
 x is the volume occupied by that gas.

Your answer

[1]

- 13 Which graph **A**, **B**, **C**, or **D** best represents the relationship between the variables x and y where:

y is the electric field strength in the space surrounding a point charge
 x is the distance from the point charge.

Your answer

[1]

- 14 Four different ions enter a region of uniform magnetic field. Each ion enters with the same velocity. The magnetic field acts at 90° to the path of the ions. Each ion is defined below in terms of its nucleon number and charge.

Which ion will travel in a circular path with the largest radius?

	nucleon number	charge
A	1	1
B	2	1
C	3	1
D	7	2

Your answer

[1]

- 15** Here are four diagrams of possible equipotentials near an isolated star. In each diagram, the difference in gravitational potentials between adjacent equipotentials is the same.

Which diagram is correct?

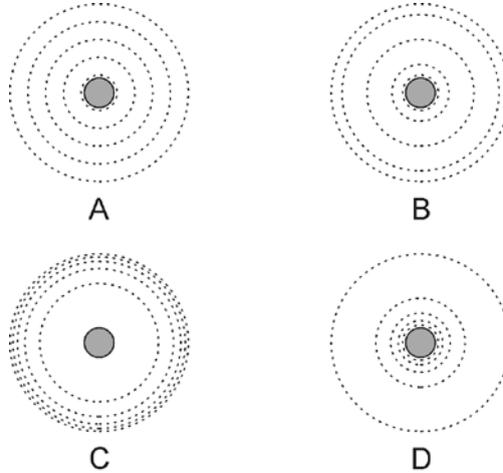

Your answer

[1]

- 16** A satellite orbits the Earth in a circular orbit of height 2.3×10^6 m above the ground.

What is the angular velocity ω of the satellite?

radius of Earth = 6.4×10^6 m.

mass of Earth = 6.0×10^{24} kg

- A** $6.1 \times 10^{-7} \text{ rad s}^{-1}$
B $3.3 \times 10^{-5} \text{ rad s}^{-1}$
C $7.8 \times 10^{-4} \text{ rad s}^{-1}$
D $5.7 \times 10^{-3} \text{ rad s}^{-1}$

Your answer

[1]

- 17 The up quark (u) has charge $+\frac{2}{3}e$ and the down quark (d) a charge of $-\frac{1}{3}e$.

What is the correct combination of quarks that make up the proton and the neutron?

	proton	neutron
A	ddd	uud
B	udd	uud
C	uud	udd
D	ddd	udd

Your answer

[1]

- 18 The graph shows the variation in quantity y with quantity x .

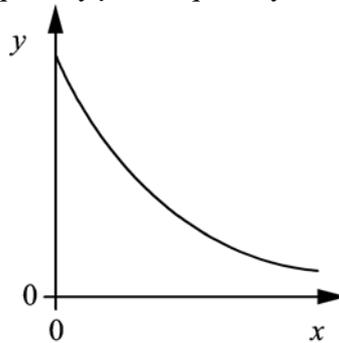

Which pair(s) of quantities produce a similar graph?

- 1 mass remaining of a radioisotope (y) against time (x)
- 2 charge (y) on a capacitor against potential difference (x) across the capacitor
- 3 gravitational field strength from a point mass (y) against distance from mass (x)

- A** 1, 2 and 3
B Only 1 and 2
C Only 2 and 3
D Only 1

Your answer

[1]

- 19** Two small metal spheres have the same electric charge. The distance between the centres of the spheres is 12 cm. The force on each sphere is 0.29 mN.

What is the electric charge on each sphere?

- A** 4.6×10^{-16} C
B 4.6×10^{-9} C
C 2.2×10^{-8} C
D 6.8×10^{-5} C

Your answer

[1]

- 20** ${}_{84}^{210}\text{Po}$ is a radioactive isotope. The equation for its decay is:

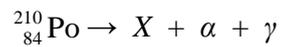

Where X is the daughter nucleus, α is an alpha particle and γ is a gamma photon.

What is the atomic number of X ?

- A** 80
B 82
C 85
D 208

Your answer

[1]

- 21 The diagram shows an ideal transformer.

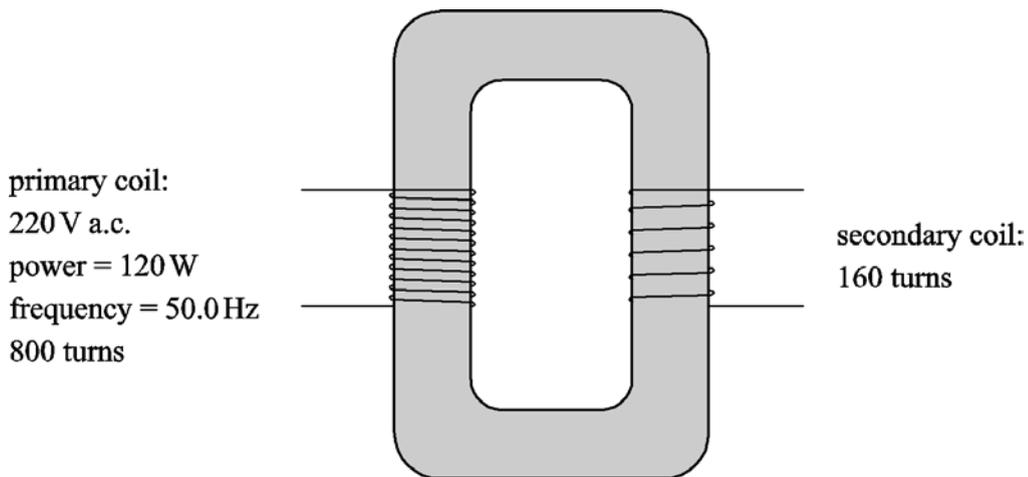

Which of the following data sets about the output of the secondary coil is correct?

	p.d. / V	<i>I</i> / A	<i>f</i> / Hz
A	44.0	2.73	10.0
B	44.0	0.11	50.0
C	44.0	2.73	50.0
D	1100	0.11	50.0

Your answer

[1]

- 22 A 4700 μF capacitor is discharged through a 2200 Ω resistor. To the nearest second, how long will it take for the charge on the capacitor to fall to half its original value?

- A** 3 s
B 5 s
C 7 s
D 10 s

Your answer

[1]

- 23 A proton enters the space between two oppositely charged parallel metal plates.

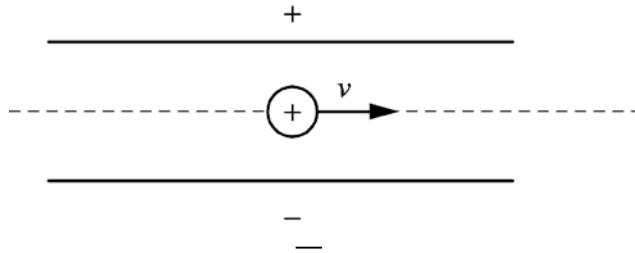

A magnetic field acts between the plates at right angles to the electric field and the direction of motion of the proton.

The magnetic field strength is 20 mT and the electric field strength is 100 V m^{-1} .

The proton moves in a straight line between the plates.

What is the speed of the proton?

- A 2000 m s^{-1}
- B 5000 m s^{-1}
- C 5 m s^{-1}
- D 2 m s^{-1}

Your answer

[1]

- 24 Here are some data about a volume of an ideal gas:

$$\text{volume} = 0.5 \times 10^{-3} \text{ m}^3$$

$$\text{pressure} = 0.25 \text{ MPa}$$

$$\text{temperature} = 30 \text{ }^\circ\text{C}$$

What is the number of particles in the volume of gas?

- A 3×10^{20}
- B 3×10^{21}
- C 3×10^{22}
- D 3×10^{23}

Your answer

[1]

The following information is for use in questions 25 and 26.

A proton 1_1p and a ${}^4_2\text{He}$ nucleus (alpha particle) are both accelerated from rest through a potential difference of 1000 V.

25 What is the ratio $\frac{\textit{kinetic energy of the proton}}{\textit{kinetic energy of the alpha particle}}$?

A $\frac{1}{4}$

B $\frac{1}{2}$

C $\frac{2}{1}$

D $\frac{4}{1}$

Your answer

[1]

26 What is the ratio $\frac{\textit{momentum of the proton}}{\textit{momentum of the alpha particle}}$?

A $\frac{1}{2\sqrt{2}}$

B $\frac{1}{\sqrt{2}}$

C $\frac{\sqrt{2}}{1}$

D $\frac{2\sqrt{2}}{1}$

Your answer

[1]

- 27 A mass M oscillates in simple harmonic motion between two fixed supports. Frictional effects can be ignored. The time period of the oscillation is T_1 .

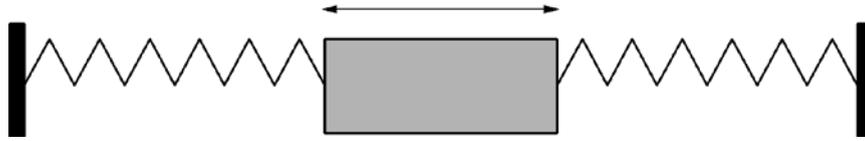

The mass is replaced with a mass of $4M$ **and** the amplitude of the oscillation is doubled. The new time period is T_2 .

Which is the correct statement?

- A $T_2 = 4T_1$
- B $T_2 = 2T_1$
- C $T_2 = T_1$
- D $T_2 = \frac{1}{2}T_1$

Your answer

[1]

- 28 The activation energy E_A for the conduction of a semiconductor diode is 0.14 eV. The operating temperature of the diode in a circuit is measured at 85 ± 4 °C. A student is considering the effect this uncertainty causes in the calculation of the Boltzmann factor $e^{-E_A/kT}$.

Which of the following statements is/are true?

- 1 The % uncertainty in the Boltzmann factor will be the same as in the temperature.
- 2 Temperatures should be expressed on the absolute scale in Kelvins for calculations with the Boltzmann factor.
- 3 The % uncertainty in T is 1.5% to two significant figures.

- A 1, 2 and 3 are correct
- B Only 1 and 2 are correct
- C Only 2 is correct
- D Only 1 is correct

Your answer

[1]

The following information is for use in questions **29** and **30**.

The ratio of masses $\frac{M_{\text{Earth}}}{M_{\text{Moon}}} \approx 80$ and the ratio of radii $\frac{r_{\text{Earth}}}{r_{\text{Moon}}} \approx 4$.

29 What is the best estimate of the ratio of gravitational fields at the surface of the two bodies $\frac{g_{\text{Earth}}}{g_{\text{Moon}}}$?

- A** 1.6
- B** 5
- C** 20
- D** 320

Your answer

[1]

30 What is the best estimate of the ratio of gravitational potentials at the surface of the two bodies $\frac{V_{\text{Earth}}}{V_{\text{Moon}}}$?

- A** 1.6
- B** 5
- C** 20
- D** 320

Your answer

[1]

SECTION B

Answer **all** the questions.

31 Fig. 31.1 shows a simple potential divider circuit.

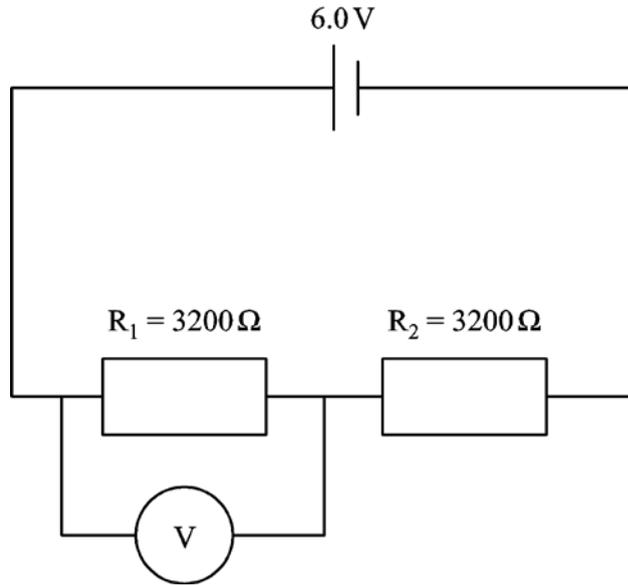

Fig. 31.1

The p.d. across R_1 is 2.9 V.

- (a) Show that R_c , the combined resistance of R_1 and the voltmeter resistance R_v , is about $3000\ \Omega$. Assume that the cell has zero internal resistance.

[2]

- (b) Calculate the resistance of the voltmeter, R_v .

resistance = [2]

32 Fig. 32.1 represents the internal structure of a metal alloy.

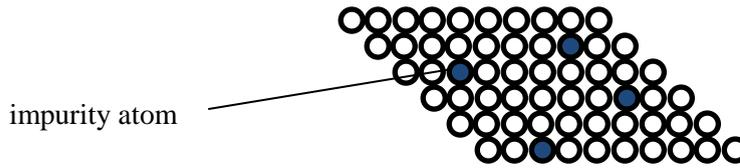

Fig. 32.1

Describe and explain how the presence of impurity atoms makes the metal harder.

.....

.....

.....

.....

..... [3]

33 Light of wavelength 633 nm passes through a diffraction grating.

The first order maximum is at an angle of 0.19 radian.

(a) Show that the grating has about 300 lines per mm.

[3]

(b) Calculate the number of orders of maximum that can be obtained from this grating with this light source.

[2]

- 34** The half-life of a muon at rest is $1.52 \mu\text{s}$. Muons in cosmic rays are observed to have half-lives of $10.4 \mu\text{s}$.

Calculate the velocity of the muons in cosmic rays.

velocity =m s⁻¹ [3]

- 35** Theory suggests that about 14×10^9 years ago the Universe was much smaller than it is now and that the temperature of the Universe was about 3000 K. Since that time, the Universe has expanded and cooled to a background temperature of about 2.8 K.

(a) State the observation that suggests that the Universe is continuing to expand.

.....
.....
.....
..... [1]

(b) The energy of photons released in the very early Universe has reduced by a factor of about 1000. Calculate the factor by which the wavelength of the photons has changed during this time.

[2]

36 Palladium-103 is a beta-emitter with a half-life of 17 days. For some cases of cancer, ‘seeds’ of palladium-103 are placed in the affected organ near the tumour and remain there: they are not removed.

- (a) In a medical procedure, a cluster of cells is exposed to the beta radiation from palladium-103. The initial activity of the source is 1.8×10^5 Bq.

Estimate the dose in gray received by a cluster of cells of mass 4.0 g after one hour.

average energy of beta particle released by palladium-103 = 3.4×10^{-15} J

dose received = Gy [2]

- (b) Evaluate the benefits and risks to the patient of this type of treatment compared with using a radioactive source outside the body.

.....

.....

.....

..... [2]

SECTION C

Answer **all** the questions.

37 This question is about the energy required to vaporise water.

A student performs a simple experiment in which she measures the change in mass of water as a kettle boils. The lid has been removed from the kettle so that the water vapour can escape.

These are her results:

mass of kettle and water at $t = 0$ s:	2.40 kg
mass of kettle and water at $t = 120$ s:	2.30 kg
power of kettle:	2100 W

She concluded that the energy required for one molecule to go into the vapour state is 7.5×10^{-20} J.

(a) Show how the student reached this value.

$$\text{molar mass of water} = 18 \text{ g mol}^{-1}$$

[3]

(b) Suggest and explain why her value of 7.5×10^{-20} J is larger than the expected value of 6.9×10^{-20} J.

.....

.....

.....

.....

[2]

38 This question is about the decay of protactinium.

Fig. 38.1 shows a graph of the natural log of corrected count rate A against time in seconds.

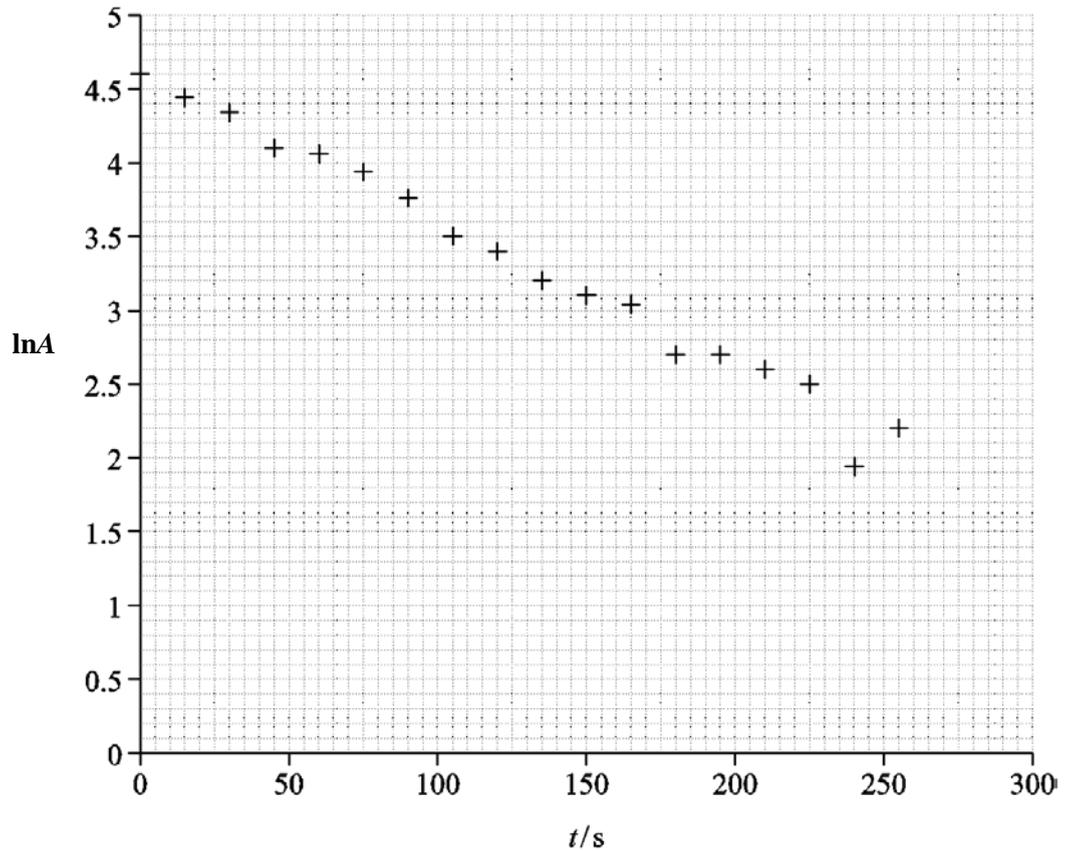

Fig. 38.1

(a) (i) Draw a best fit line on Fig. 38.1.

The equation of the line is $\ln A = \ln A_0 - \lambda t$ where λ is the decay constant and A_0 is the initial activity of the source.

Use this to show that the decay constant of the protactinium is about 0.01 s^{-1} .

[3]

- 39** This question is about the electron in the hydrogen atom. A simple model shown in **Fig. 39.1** pictures the electron as a standing wave in a box of length equal to the diameter of the atom. The electron can be bound to the proton if the total energy of the electron (kinetic energy + potential energy) is less than zero.

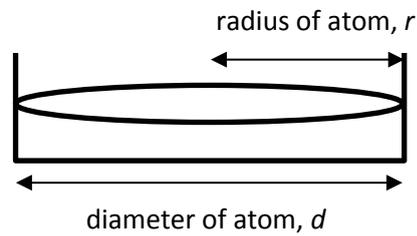

Fig. 39.1

- (a) (i) Show that the kinetic energy of the electron in a box of diameter d is $\frac{h^2}{32mr^2}$.

[3]

- (ii) Calculate the kinetic energy of an electron trapped in a box of $r = 1 \times 10^{-10}$ m.

kinetic energy = J [2]

- (iii) Calculate the electrical potential energy of an electron at a distance of 1×10^{-10} m from a proton. Use this value and your answer from (a)(ii) to explain why an electron can be bound to a proton at this distance.

$$k = 9.0 \times 10^9 \text{ N m}^2 \text{ C}^{-2}$$

[4]

- (b) In beta decay of a nucleus, a neutron decays into a proton and an electron.

Taking the radius of a nucleus to be about 10^{-14} m, explain, with supporting calculations, why the electron immediately leaves the nucleus.

.....

.....

.....

.....

.....

.....

.....

.....

.....

.....

[4]

40 This question is about energy from a nuclear power plant.

A power plant generator produces a voltage of 25 kV a.c. The electrical power output of such a plant is about 500 MW. A transformer of turns ratio 1:16 is used to step up the voltage for transmission along the high voltage cables.

(a) Calculate the current in the cables at the higher voltage.

current = A [2]

The equation below shows one of many ways that uranium-235 can undergo fission.

(b) (i) Explain how this process can form a chain reaction and why a minimum mass of uranium is required for the reaction to proceed.

.....

.....

.....

.....

..... [3]

(ii) Here are the masses of the particles in the reaction:

neutron	=	1.0087 u
uranium-235	=	235.0439 u
barium-141	=	140.9144 u
krypton-92	=	91.9261 u

Calculate the energy released in one fission reaction:

$$u = 1.7 \times 10^{-27} \text{ kg}$$

energy released = J [3]

- (c) Most working power plants use enriched uranium which contains about 3% uranium-235 which undergoes fission, and 97% uranium-238 which does not undergo fission. A promising alternative fuel to uranium-235 is uranium-233. This is produced from the plentiful isotope thorium-232 which is converted into thorium-233 by neutron bombardment followed by beta-decay.

Research into uranium-233 reactors was abandoned in the 1970s as uranium-235 plants produce plutonium-239, which was needed for nuclear weapons. Research has recently resumed into obtaining fuel from thorium-232.

Here are some data about a proposed uranium-233 power plant:

energy released per reaction = 200 MeV

mean power generated by fission reactions = 1400 MW

mass of thorium-232 atom = mass of uranium-233 atom = 4×10^{-25} kg (1 significant figure)

Use this data to calculate an estimate of the total mass of thorium-232 used in one year, and suggest one reason why research into nuclear fuel obtained from thorium has started again after being abandoned for 40 years.

1 year = 3.2×10^7 s

1 eV = 1.6×10^{-19} J

mass used per year = kg [4]

- 41 This question is about sampling sounds. **Fig. 41.1** shows part of a waveform. This waveform has been sampled at the points shown by small circles.

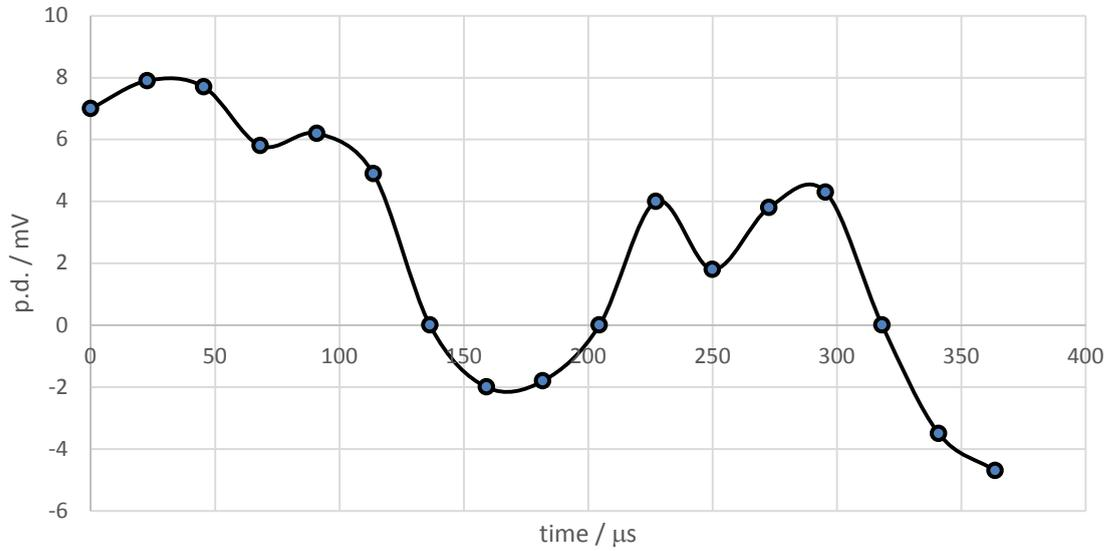

Fig.41.1

The sampling rate is 44 kHz.

- (a) On **Fig. 41.1** sketch the waveform that would be reproduced if the sample rate is reduced to 22 kHz. Explain your reasoning and state how the reproduced waveform will differ from the original waveform.

.....

.....

.....

.....

.....

[3]

- (b) A student estimates that the system uses 50 000 voltage levels. Calculate how many bits are required to produce this number of levels and suggest a more likely value for the number of voltage levels.

[3]

- (c) This system is used for high quality sound. Explain why it is necessary to sample at a frequency of 44 kHz when the highest note that can be heard is about 20 000 Hz.

[2]

- (d) Telephone systems are often designed to use 8 bit sampling at 8 kHz instead of the 16 bit sampling at 44 kHz used for music. Suggest and explain why this decision was made in designing those systems and explain why recorded music can sound distorted on a telephone.

.....

.....

.....

.....

.....

.....

.....

.....

.....

[3]

END OF QUESTION PAPER

Copyright Information:

OCR is committed to seeking permission to reproduce all third-party content that it uses in the assessment materials. OCR has attempted to identify and contact all copyright holders whose work is used in this paper. To avoid the issue of disclosure of answer-related information to candidates, all copyright acknowledgements are reproduced in the OCR Copyright Acknowledgements booklet. This is produced for each series of examinations and is freely available to download from our public website (www.ocr.org.uk) after the live examination series.

If OCR has unwittingly failed to correctly acknowledge or clear any third-party content in this assessment material, OCR will be happy to correct its mistake at the earliest possible opportunity.

For queries or further information please contact the Copyright Team, First Floor, 9 Hills Road, Cambridge CB2 1GE.

OCR is part of the Cambridge Assessment Group; Cambridge Assessment is the brand name of University of Cambridge Local Examinations Syndicate (UCLES), which is itself a department of the University of Cambridge.



...day June 20XX–Morning/Afternoon

A Level Physics B (Advancing Physics)

H557/01 Fundamentals of physics

SAMPLE MARK SCHEME

Duration: 2 hours 15 minutes

MAXIMUM MARK 110



This document consists of 20 pages

MARKING INSTRUCTIONS**PREPARATION FOR MARKING****SCORIS**

1. Make sure that you have accessed and completed the relevant training packages for on-screen marking: *scoris assessor Online Training*; *OCR Essential Guide to Marking*.
2. Make sure that you have read and understood the mark scheme and the question paper for this unit. These are posted on the RM Cambridge Assessment Support Portal <http://www.rm.com/support/ca>
3. Log-in to scoris and mark the **required number** of practice responses (“scripts”) and the **required number** of standardisation responses.

YOU MUST MARK 10 PRACTICE AND 10 STANDARDISATION RESPONSES BEFORE YOU CAN BE APPROVED TO MARK LIVE SCRIPTS.

MARKING

1. Mark strictly to the mark scheme.
2. Marks awarded must relate directly to the marking criteria.
3. The schedule of dates is very important. It is essential that you meet the scoris 50% and 100% (traditional 50% Batch 1 and 100% Batch 2) deadlines. If you experience problems, you must contact your Team Leader (Supervisor) without delay.
4. If you are in any doubt about applying the mark scheme, consult your Team Leader by telephone, email or via the scoris messaging system.

5. Work crossed out:
- a. where a candidate crosses out an answer and provides an alternative response, the crossed out response is not marked and gains no marks
 - b. if a candidate crosses out an answer to a whole question and makes no second attempt, and if the inclusion of the answer does not cause a rubric infringement, the assessor should attempt to mark the crossed out answer and award marks appropriately.
6. Always check the pages (and additional objects if present) at the end of the response in case any answers have been continued there. If the candidate has continued an answer there then add a tick to confirm that the work has been seen.
7. There is a NR (No Response) option. Award NR (No Response)
- if there is nothing written at all in the answer space
 - OR if there is a comment which does not in any way relate to the question (e.g. 'can't do', 'don't know')
 - OR if there is a mark (e.g. a dash, a question mark) which isn't an attempt at the question.

Note: Award 0 marks – for an attempt that earns no credit (including copying out the question).

8. The scoris **comments box** is used by your Team Leader to explain the marking of the practice responses. Please refer to these comments when checking your practice responses. **Do not use the comments box for any other reason.**
- If you have any questions or comments for your Team Leader, use the phone, the scoris messaging system, or e-mail.
9. Assistant Examiners will send a brief report on the performance of candidates to their Team Leader (Supervisor) via email by the end of the marking period. The report should contain notes on particular strengths displayed as well as common errors or weaknesses. Constructive criticism of the question paper/mark scheme is also appreciated.

10. For answers marked by levels of response:

- Read through the whole answer from start to finish.
- Decide the level that **best fits** the answer – match the quality of the answer to the closest level descriptor.
- To select a mark within the level, consider the following:
 - Higher mark:** A good match to main point, including communication statement (in italics), award the higher mark in the level
 - Lower mark:** Some aspects of level matches but key omissions in main point or communication statement (in italics), award lower mark in the level.

Level of response questions on this paper are **37(c) and 38(b)**.

11. Annotations

Annotation	Meaning
DO NOT ALLOW	Answers which are not worthy of credit
IGNORE	Statements which are irrelevant
ALLOW	Answers that can be accepted
()	Words which are not essential to gain credit
—	Underlined words must be present in answer to score a mark
ECF	Error carried forward
AW	Alternative wording
ORA	Or reverse argument

12. Subject-specific Marking Instructions

INTRODUCTION

Your first task as an Examiner is to become thoroughly familiar with the material on which the examination depends. This material includes:

- the specification, especially the assessment objectives
- the question paper
- the mark scheme.

You should ensure that you have copies of these materials.

You should ensure also that you are familiar with the administrative procedures related to the marking process. These are set out in the OCR booklet **Instructions for Examiners**. If you are examining for the first time, please read carefully **Appendix 5 Introduction to Script Marking: Notes for New Examiners**.

Please ask for help or guidance whenever you need it. Your first point of contact is your Team Leader.

SECTION A

Question	Answer	Marks	Guidance
1	C	1	
2	D	1	
3	D	1	
4	D	1	
5	C	1	
6	D	1	
7	C	1	
8	A	1	
9	B	1	
10	A	1	
11	C	1	
12	B	1	
13	C	1	
14	D	1	
15	D	1	
16	C	1	
17	C	1	
18	D	1	
19	C	1	
20	B	1	
21	C	1	
22	C	1	
23	B	1	
24	C	1	
25	B	1	
26	A	1	
27	B	1	
28	C	1	
29	B	1	
30	C	1	
	Total	30	

SECTION B

Unless stated otherwise, correct numerical answer gains full credit

Question		Answer	Marks	Guidance
31	(a)	$2.9 = 6.0 \times (R_c / (R_c + 3200)) \checkmark$ $R_c = 2994 \Omega \checkmark$	2	Accept RA: $V = 6 \times (3000/6200) \checkmark$ $= 2.90 \text{ V} \checkmark$ Correct answer gains 2 marks.
	(b)	$1/2994 = 1/3200 + 1/R_v \checkmark$ $R_v = 46500 (\Omega) \checkmark$	2	Bald answer acceptable. Look for working from 3000Ω and working using conductance.
Total			4	
32		Any three from: less ductile Plastic flow reduced Alloying atoms pin (AW) dislocations or dislocations less mobile Reducing distance planes of atoms slip over one another or less slip	3	
Total			3	

Question		Answer	Marks	Guidance
33	(a)	$6.33 \times 10^{-9} = d \times \sin(0.19) \checkmark$ $d = 3.4 \times 10^{-6} \checkmark$ working though to lines per mm (298) \checkmark	3	Bald answer not acceptable
	(b)	$n\lambda = d \sin\theta$. Recognition that $\sin\theta = 1 \checkmark$ $n = 3.4 \times 10^{-6} / 6.33 \times 10^{-7} = 5.4 = 5 \text{ orders} \checkmark$	2	
		Total	5	
34		$\gamma = 6.84 \checkmark$ $= 1/\sqrt{1 - v^2/c^2}$ Working through to $v^2/c^2 = 0.979 \checkmark$ Working through to $v = 2.97 \times 10^8 \text{ (m s}^{-1}\text{)} \checkmark$	3	
		Total	3	
35	(a)	Red shift of (distant) galaxies \checkmark	1	Accept Hubble's law
	(b)	$\lambda = hc/E$ rearrangement \checkmark By calculation or simple ratio , increase in $\lambda = 1000 \text{ times} \checkmark$	2	
		Total	3	
36	(a)	$1.8 \times 10^5 \times 60 \times 60 \times 3.4 \times 10^{-15} / 4 \times 10^{-3} \checkmark$ $= 0.000 55 \text{ (Gy)} \checkmark$	2	
	(b)	Benefit: will destroy cancerous cells more effectively if it is in the organ; will prevent cancer returning in the following days; will have less affect on surrounding tissues. Risk: radioactive emission will continue for some time and could damage other tissues; surgery may damage the patient; the actual 'seed' could be poisonous.	2	One mark in each category not just 'will kill the cancer'
		Total	4	

Section C

Question		Answer	Marks	Guidance
37	(a)	energy supplied = 252000 J ✓ energy supplied/ mol = 45 360 J ✓ energy per molecule = 7.53×10^{-20} J ✓	3	credit reverse argument. Clear working required. number of molecules evaluated as 3.3×10^{24}
	(b)	Not all energy transferred from heater to water ✓ Alternative destination of energy transfer or vapour recondensing into kettle ✓	2	
	(c)*	Level 3 (5–6 marks) Marshals argument in a clear manner linking the idea of particle collisions and gaining energy with the model with the definition/explanation of the mathematical formalism of the BF. Shows clear working of BF ratio leading to answer in range <i>There is a well-developed line of reasoning which is clear and logically structured. The information presented is relevant and substantiated.</i> Level 2 (3–4 marks) Covers at least two aspects of the argument. Physics correct but perhaps not sufficiently detailed / doesn't cover enough indicative points. Mathematical aspect poorly worked or inaccurate. <i>There is a line of reasoning presented with some structure. The information presented is in the most-part relevant and supported by some evidence.</i>	6	Indicative scientific points may include: Particle collisions: <ul style="list-style-type: none"> • Particles exchange energy on collisions • Some particles will gain energy in a number of consecutive collisions • This can lead to particles with sufficient energy to evaporate Boltzmann factor <ul style="list-style-type: none"> • Gives the ratios of particles in energy states differing by ϵ • Linking this ratio to the probability of a particle moving from one energy state to the next(classical) particles cannot superpose Comparison of rates: <ul style="list-style-type: none"> • Rate of evaporation proportional to BF • Explanation of the above point (greater probability mean that more will leave the liquid per second)

Question	Answer	Marks	Guidance
	<p>Level 1 (1–2 marks) Makes two expected points but the answer is superficial and incomplete.</p> <p><i>The information is basic and communicated in an unstructured way. The information is supported by limited evidence and the relationship to the evidence may not be clear.</i></p> <p>0 marks No response or no response worthy of credit.</p>		<ul style="list-style-type: none"> • Clear mathematical working – either direct or via natural logs. For example: $\ln(f_{303}/f_{293}) = 293/303$ • Answer in range 1.5 – 2.7 (variation large because BF so sensitive to intermediate roundings if candidate calculate individual E/kT values)
	Total	11	

Question			Answer	Marks	Guidance
38	(a)	(i)	<p>Good best fit line, with ruler ✓</p> <p>Two pairs of points taken from line, x values separated by at least 150 s. ✓</p> <p>Calculation of gradient eg. $1/100 = 0.01 \text{ s}^{-1}$ ✓</p>	3	A candidate could calculate the half life by subtracting 0.693 from a y value and finding the difference in x, or by converting ln values to count rate. This is acceptable. Read offs correct to half a small square.
		(ii)	<p>Half-life = $0.693/0.01$ ✓</p> <p>= 69 (s) ✓</p>	2	Range of values from candidates decay constant
	(b)*		<p>Level 3 (5–6 marks) Marshals argument in a clear manner and includes clear explanation of three strands:</p> <ul style="list-style-type: none"> • randomness • the exponential curve as a model • the effect of the number of nuclei present <p><i>There is a well-developed line of reasoning which is clear and logically structured. The information presented is relevant and substantiated.</i></p> <p>Level 2 (3–4 marks) Shows clear understanding of at least two of the three strands above to the argument or covers all three at a superficial manner and does not include enough indicative points for level 3.</p> <p><i>There is a line of reasoning presented with some structure. The information presented is in the most-part relevant and supported by some evidence.</i></p>	6	<p>Indicative scientific points may include:</p> <p>Randomness</p> <ul style="list-style-type: none"> • cannot know when an individual nucleus will decay • explanation of the meaning of the decay constant (e.g. probability of decay of individual nucleus in unit time) • λ as the probability related to dN/dt • discussion of an analogue (e.g. coins or dice) <p>The exponential curve as a model</p> <ul style="list-style-type: none"> • reference in correct context to $N = N_0 e^{-\lambda t}$ or • linking to $dN/dt = -\lambda t$ <p>The effect of the number of nuclei present</p> <ul style="list-style-type: none"> • for fixed λ the number of nuclei decaying in a given time can be predicted given sufficiently large sample • as count rate falls, the number of nuclei that may decay also falls • as the number of nuclei falls the variation from the predicted outcome will increase

Question		Answer	Marks	Guidance
		<p>Level 1 (1–2 marks) Makes at least two independent points that are relevant to the argument but does not link them together and shows only superficial engagement with the argument.</p> <p><i>The information is basic and communicated in an unstructured way. The information is supported by limited evidence and the relationship to the evidence may not be clear.</i></p> <p>0 marks No response or no response worthy of credit.</p>		<ul style="list-style-type: none"> • with increase variation comes increasing scatter
		Total	11	

Question			Answer	Marks	Guidance
39	(a)	(i)	$ke = p^2/2m$ ✓ $p^2 = h^2/\lambda^2$ ✓ $\lambda = 4r$ ✓ therefore $E = h^2/32mr^2$	3	Some steps can be in different order but the derivation must be clear. Allow starting point of $\lambda = h/mv$ and $ke = \frac{1}{2}mv^2$ to reach same conclusion.
		(ii)	$ke = ((h^2/(32 \times 9.1 \times 10^{-31} \times 1 \times 10^{-20})))$ ✓ $1.5 \times 10^{-18} \text{ (J)}$ ✓	2	
		(iii)	potential energy = $- 8.9 \times 10^9 \times (1.6 \times 10^{-19})^2 / 1 \times 10^{-10}$ ✓ $= -2.3 \times 10^{-18}$ ✓ Total energy = $-0.8 \times 10^{-18} \text{ J}$ ✓ This is negative, hence electron bound to proton. ✓	4	Must include negative sign for second marking point.
	(b)		Calculation of k.e = $1.5 \times 10^{-10} \text{ J}$ ✓ Calculation of p.e. = $-2.3 \times 10^{-14} \text{ J}$ ✓ Total energy = $1.5 \times 10^{-10} \text{ J}$ ✓ This is a positive value hence electron will escape AW ✓	4	Calculations are expected to be made by simple ratio of results from (a) and change in ratio. Recalculations are acceptable. Negative sign required. ‘Total energy now positive’ without support gains one mark.
Total				13	

Question		Answer	Marks	Guidance
40	(a)	current = $500 \times 10^6 / (25 \times 10^3 \times 16)$ ✓ = 1250 (A) ✓	2	
	(b) (i)	neutrons released can cause other fission events ✓ if at least one neutron released per event triggers a second event the reaction is self sustaining ✓ If mass too small too many neutrons will escape without triggering secondary fissions AW ✓	3	
	(ii)	mass difference = 0.186 u ✓ mass difference/kg = 3.16×10^{-28} kg ✓ energy released = 2.85×10^{-11} J ✓	3	
	(c)	energy output per year = 4.48×10^{16} J ✓ energy per fission = $200 \times 10^6 \times 1.6 \times 10^{-19}$ J = 3.2×10^{-11} J number of fissions = 4.48×10^{16} J / 3.2×10^{-11} J = 1.4×10^{27} ✓ Mass of thorium used = $1.4 \times 10^{27} \times 4 \times 10^{-25}$ kg = 600 kg ✓ Reason for resuming research into thorium reactors: any one from: shortage of uranium makes thorium more economic/ end of nuclear arms race makes plutonium less needed/ so much energy is needed that all potential sources must be used ✓	4	accept 560 kg. Award final mark only for answers recorded to no more than 2sf.
		Total	12	

Question		Answer	Marks	Guidance
41	(a)	(straight) line passing through every second point ✓ Reasoning: half the frequency, twice the time interval between sample AW ✓ Effect: detail in the waveform lost e.g. high frequency components lost ✓	3	Ignore shape of line between points
	(b)	Number of bits used = \log_2 (number of levels) ✓ = 15.6 (therefore 16) ✓ More likely to use 65536 (or rounded value) ✓	3	65536 = 2^{16} , accept 64k
	(c)	Need to have sampling frequency of at least 2 x frequency of highest note ✓ Higher frequency components of music give overall sound ✓	2	musical knowledge NOT required.
	(d)	Any three from: <ul style="list-style-type: none"> • Smaller information transfer rate required • Accurate reproduction of voices not needed for understanding telephone conversations • Conversations uses a more limited frequency range than music • Only 256 voltage levels • Only frequencies up to about 4000 Hz can be accurately reproduced • Music requires higher sampling rate to show different instruments • Music requires 16 bit sampling to give smoother changes in dynamics 	3	
Total			11	

BLANK PAGE

BLANK PAGE

BLANK PAGE

BLANK PAGE