

**ADVANCED GCE  
 PHYSICS B (ADVANCING PHYSICS)**

**2865/01**

Advances in Physics

**FRIDAY 25 JANUARY 2008**

Morning

Time: 1 hour 30 minutes

Candidates answer on the question paper.

**Additional materials:** Insert (Advance Notice Article for this question paper)  
 Data, Formulae and Relationships Booklet  
 Electronic calculator  
 Ruler

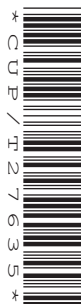

Candidate Forename

Candidate Surname

Centre Number

Candidate Number

**INSTRUCTIONS TO CANDIDATES**

- Write your name in capital letters, your Centre Number and Candidate Number in the boxes above.
- Answer **all** the questions.
- Use blue or black ink. Pencil may be used for graphs and diagrams only.
- Read each question carefully and make sure you know what you have to do before starting your answer.
- Show clearly the working in all calculations, and give answers to only a justifiable number of significant figures.
- Do **not** write in the bar codes.
- Do **not** write outside the box bordering each page.
- Write your answer to each question in the space provided.

For Examiner's Use		
Qu.	Max	Mark
1	10	
2	9	
3	7	
4	8	
5	8	
6	9	
7	8	
8	13	
9	14	
<b>QWC</b>	4	
<b>Total</b>	<b>90</b>	

**INFORMATION FOR CANDIDATES**

- The number of marks for each question is given in brackets [ ] at the end of each question or part question.
- The total number of marks for this paper is **90**.
- Section A (questions 1–7) is based on the Advance Notice article, a copy of which is included as an insert. You are advised to spend about 60 minutes on Section A.
- There are four marks for the quality of written communication on this paper.
- The values of standard physical constants are given in the Data, Formulae and Relationships booklet. Any additional data required are given in the appropriate question.

This document consists of **21** printed pages, **3** blank pages and an insert.

Answer **all** the questions.

**Section A**

**1** This question is about calculations based on the Earth's orbital period (a year) (lines 4–11 in the article).

**(a)** The Earth is a mean distance of  $1.50 \times 10^{11}$  m from the Sun.

**(i)** Show that the orbital speed of the Earth is about  $3 \times 10^4$   $\text{ms}^{-1}$ .  
 $1 \text{ year} = 3.2 \times 10^7 \text{ s}$

[2]

**(ii)** Show that the centripetal acceleration of the Earth is about  $6 \times 10^{-3}$   $\text{ms}^{-2}$ .

[2]

**(iii)** The centripetal acceleration of the Earth, measured in  $\text{ms}^{-2}$ , is exactly the same as the Sun's gravitational field strength  $g_{\text{Sun}}$  at the Earth's orbit, measured in  $\text{Nkg}^{-1}$ . Show that the units  $\text{ms}^{-2}$  and  $\text{Nkg}^{-1}$  are equivalent.

- (b) A student has found more accurate values of data and uses them to calculate the mass of the Sun.

$$\begin{aligned} \text{At Earth, } g_{\text{Sun}} &= 5.9306 \times 10^{-3} \text{ N kg}^{-1} \\ R &= 1.49598 \times 10^{11} \text{ m} \\ G &= 6.673 \times 10^{-11} \text{ N m}^2 \text{ kg}^{-2} \end{aligned}$$

$$\begin{aligned} g_{\text{Sun}} &= \frac{GM}{R^2} \text{ so } M = \frac{g_{\text{Sun}} \times R^2}{G} = \frac{5.9306 \times 10^{-3} \times (1.49598 \times 10^{11})^2}{6.673 \times 10^{-11}} \\ &= 1.988973896 \times 10^{30} \text{ kg} \end{aligned}$$

Round the answer to an appropriate number of significant figures, and explain how you have decided how many significant figures are appropriate.

[2]

- (c) The orbital period of the Earth is not 365.25 days but 365.24 days. Explain why this has made it necessary to adopt the rule for leap years that only century years divisible by 400 have an extra day (lines 9 and 10 in the article). A calculation is not required.

[2]

[Total: 10]

- 2 This question is about water clocks (lines 16–29 and Figs. 1 and 2 in the article). Fig. 2.1 shows the markings at equal time intervals on the inside of a simple water clock. The front has been cut away to show the scale. Fig. 2.2 shows the scale with a ruler laid alongside it.

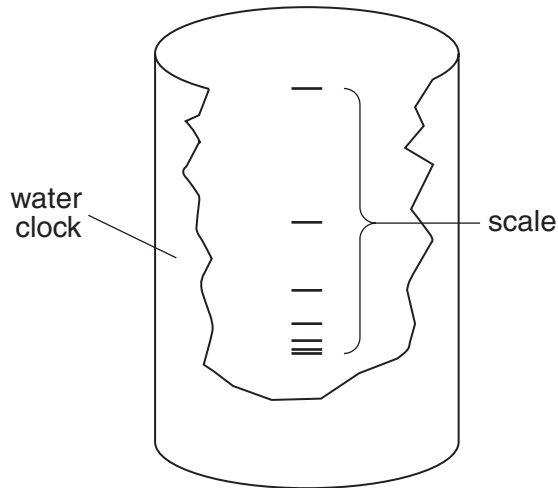

Fig. 2.1

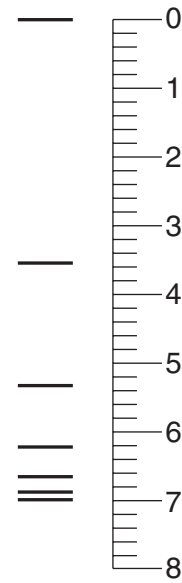

Fig. 2.2

- (a) Explain how the scale shows that the rate of flow of water decreases with time.

[1]

- (b) It is expected that the rate of flow of water will drop exponentially with time.

- (i) Use the ruler in Fig. 2.2 to make measurements of the scale and check whether the water level decreases exponentially.

[2]

- (ii) Suggest and explain changes that could be made to the design of the water clock to measure smaller time intervals.

[2]

- (c) The following data show  $\varepsilon/kT$  and the Boltzmann factor in one northern European and one Mediterranean location in summer, where  $\varepsilon$  is the energy needed to evaporate one water molecule from the liquid.

location	summer temperature $T/K$	$\varepsilon/kT$	Boltzmann factor $e^{-\frac{\varepsilon}{kT}}$
Scotland	290	17.0	$4.18 \times 10^{-8}$
Egypt	310	15.9	

- (i) Use data from the table to show that the energy  $\varepsilon$  is about  $7 \times 10^{-20}$  J.  
 $k = 1.4 \times 10^{-23} \text{ J K}^{-1}$

[1]

- (ii) Show that the Boltzmann factor in Egypt is about 3 times greater than that in Scotland.

[1]

- (iii) Explain why evaporation was ‘a considerable source of inaccuracy in the Mediterranean countries’ (lines 28–29 in the article).

[2]

[Total: 9]

**[Turn over**

3 This question is about oscillations in mechanical clocks.

(a) The earliest mechanical clocks had a rotating foliot (lines 31–41 and Fig. 3 in the article).

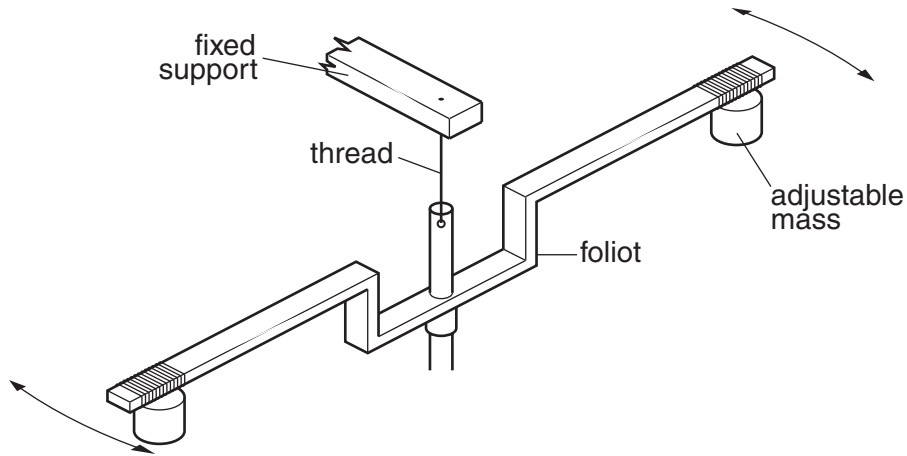

Fig. 3.1

The period of oscillation of a rotating foliot is controlled by moving the masses in or out.

Here are some values of period  $T$  for different positions of the masses, where  $R$  is the distance of each mass from the centre.

$R/\text{cm}$	$T/\text{s}$
10.0	0.94
11.0	1.05
12.0	1.17
13.0	1.29

Plan and perform a simple mathematical test to check whether  $T$  is **directly proportional** to  $R$ .

<b>Test</b>	<b>Result</b>
<b>Conclusion</b>	

[2]

- (b) Pendulum clocks are more accurate than the early foliot clocks. (lines 42–51 in the article).

The equation for the period of a pendulum is given by

$$T = 2\pi\sqrt{\frac{L}{g}}$$

where  $L$  is the length of the pendulum and  $g$  the gravitational field strength.

- (i) A 'seconds pendulum' takes one second to go from one side to the other, as shown in Fig. 3.2.

$$g = 9.8 \text{ N kg}^{-1}$$

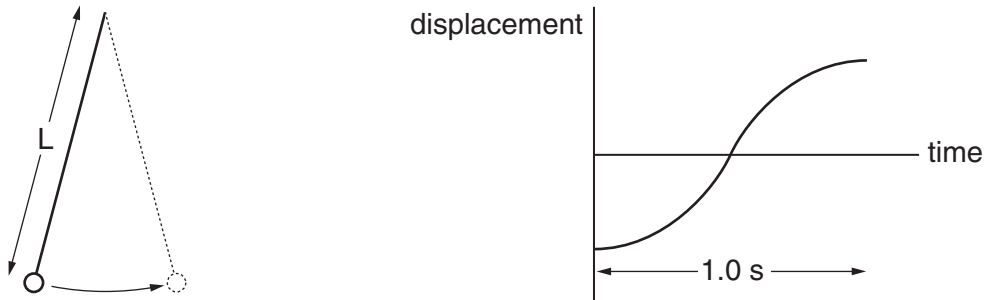

**Fig. 3.2**

Show that this pendulum has a length  $L$  of about 1 m.

[3]

- (ii) A simple pendulum will expand by  $\frac{1}{50000}$  of its original length for every  $^{\circ}\text{C}$  rise in temperature. The period  $T$  of the simple pendulum clock is 2.0000 s at  $0^{\circ}\text{C}$ . Calculate the increase in its period  $T$  when the temperature is  $25^{\circ}\text{C}$ .

increase in period ..... s [2]

[Total: 7]

- 4 This question is about oscillations in quartz crystals (lines 52–67 in the article). Fig. 4.1 shows an oscillating quartz crystal.

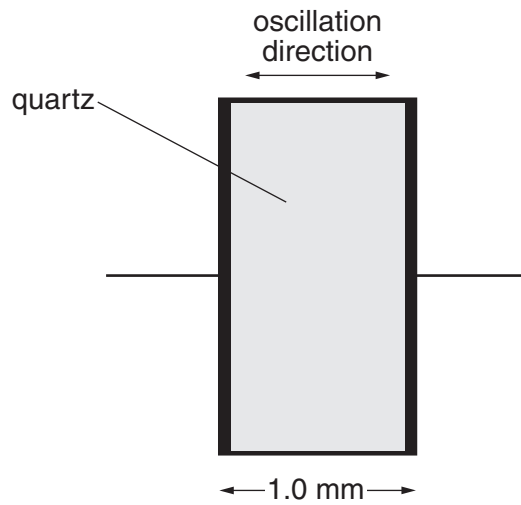

**Fig. 4.1**

- (a) (i) The crystal is oscillating in its fundamental mode. Use information from the diagram to explain why the wavelength of the ultrasound in the crystal is  $2.0 \times 10^{-3}$  m.

[1]

- (ii) Calculate the fundamental frequency of oscillation of the quartz crystal.  
speed of ultrasound in quartz,  $v = 5500 \text{ m s}^{-1}$

frequency = ..... Hz [2]



- (b) In the piezoelectric effect, an electric field  $E$  in a quartz crystal produces a strain  $\varepsilon$  given by the equation

$$\varepsilon = k_p E$$

where  $k_p$  is the piezoelectric coefficient.

- (i) Show that a p.d. of 5.0V applied to the 1.0 mm thick crystal of Fig. 4.1 will cause a change in size of  $1.1 \times 10^{-11}$  m.  
piezoelectric coefficient for quartz,  $k_p = 2.25 \times 10^{-12} \text{ mV}^{-1}$

[3]

- (ii) Calculate the stress in the 1.0 mm thick crystal produced by the p.d. of 5.0V.  
Young modulus of quartz =  $7.9 \times 10^{10} \text{ Pa}$

stress = ..... unit .....[2]

[Total: 8]

5 This question is about ammonia molecular clocks (lines 69–78 in the article).

- (a) Fig. 5.1 A shows one of the  ${}^1_1\text{H}$  hydrogen atoms oscillating in an ammonia molecule. Fig. 5.1 B is a model which treats the hydrogen atom as a mass  $m$  attached to a fixed point by a springy bond of spring constant  $k$ .

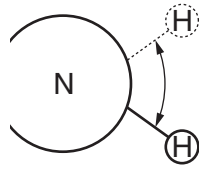

Fig. 5.1 A

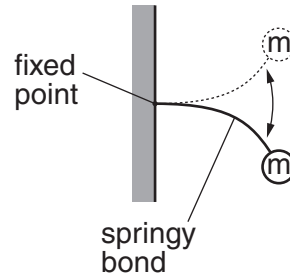

Fig. 5.1 B

- (i) The  ${}^{14}_7\text{N}$  nitrogen atom is treated in this model as a fixed point. Explain in detail why it is a reasonable approximation to assume the nitrogen atom does not move.

[2]

- (ii) Use the model to predict and explain what would happen to the resonant frequency of the system if the  ${}^1_1\text{H}$  hydrogen atoms were replaced by atoms of the more massive isotope  ${}^2_1\text{H}$ . No calculation is necessary.

[3]

- (b) In fact, as shown in Fig. 5 in the article, there are two stable positions for the hydrogen atoms.

Fig. 5.2 shows how the potential energy of a hydrogen atom varies with displacement above and below the nitrogen atom.

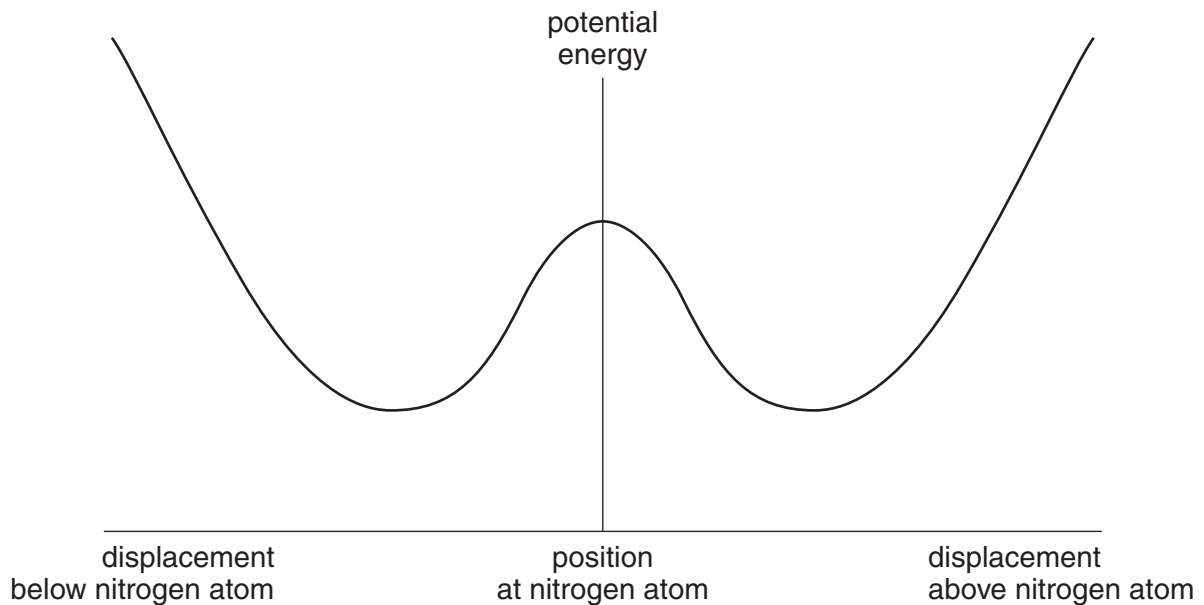

**Fig. 5.2**

- (i) Explain how Fig. 5.2 shows that there are two stable positions for the hydrogen atom.

[1]

- (ii) Mark with an **X** one place on the potential energy curve of Fig. 5.2 where the resultant force on a hydrogen atom is directed **away** from the nitrogen atom. Explain your reasoning.

[2]

[Total: 8]

**[Turn over**

- 6 This question is about caesium atomic clocks (lines 79–105 and Fig. 6 in the article). Fig. 6.1 shows the electron energy transition in a caesium atom responsible for the principal line in the spectrum.

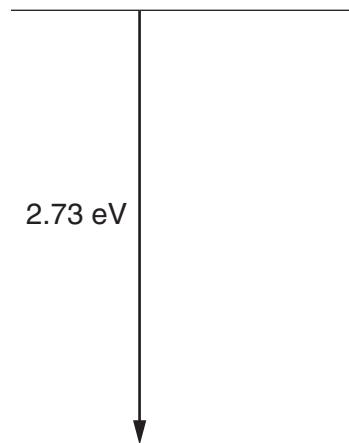

**Fig. 6.1**

- (a) (i) Make suitable calculations to show that the article is justified in claiming that the colour of the principal line in the caesium spectrum is blue (lines 86–88 in the article). Wavelengths in the visible spectrum range from about 400 nm to about 700 nm.

$$c = 3.0 \times 10^8 \text{ m s}^{-1}$$

$$e = 1.6 \times 10^{-19} \text{ C}$$

$$h = 6.6 \times 10^{-34} \text{ J s}$$

[4]

- (ii) Explain why ‘the small energy level change responsible for the 9 GHz radiation cannot easily be shown on the same energy level diagram as the transition causing the blue colour in the spectrum of caesium’ (lines 86–88 in the article).

[1]

- (b) The caesium clock has an accuracy of between 2 and 3 parts in  $10^{14}$ . Show that this corresponds to a time measurement accurate to almost one second in ten million years (lines 104–105 in the article).  
1 year =  $3.2 \times 10^7$  s

[1]

- (c) 'Digital electronic circuits are then used to divide the frequency of the oscillator producing the microwaves step by step until a frequency of exactly 5 MHz is produced' (lines 94–95 in the article).
- (i) If each stage divides the frequency by two, calculate the number of stages needed to reduce the frequency from 9.2 GHz to a frequency **near** the required 5 MHz output.

[2]

- (ii) Explain why electronic circuits which simply divide by two are not sufficient to give a frequency of **exactly** 5 MHz from the caesium clock frequency of 9 192 631 770 Hz.

[1]

[Total: 9]

7 This question is about the use of Global Positioning System (GPS) satellites to determine position on the Earth (lines 107–118 and Fig. 7 in the article).

Fig. 7.1 shows two such satellites **A** and **B** sending signals to a receiver **R**.

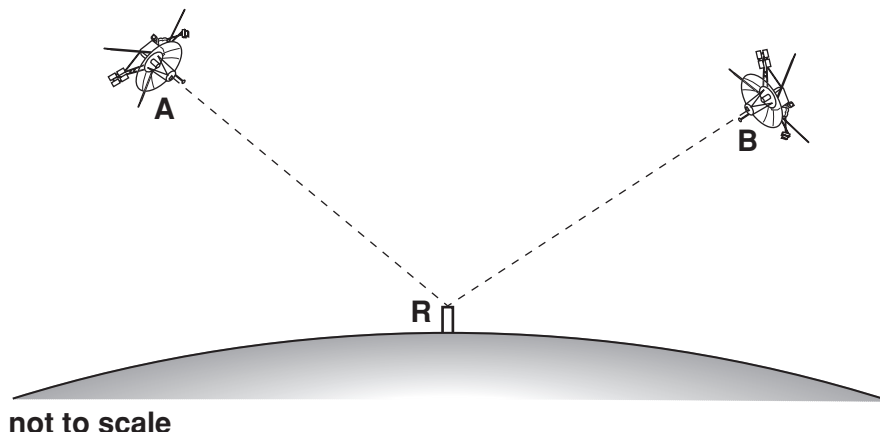

Fig. 7.1

- (a) (i) If the signal from satellite **A** is received  $1.0\ \mu\text{s}$  before that from satellite **B**, calculate the difference in length between paths **AR** and **BR**.  
 $c = 3.0 \times 10^8\ \text{ms}^{-1}$

difference in length ..... m [1]

- (ii) The caesium clocks on the satellites are accurate to the nearest  $10^{-14}\ \text{s}$ . How accurate must the quartz clock in the GPS receiver **R** be to measure distances to an accuracy of 10m?

[2]

(b) The satellites continually broadcast at a rate of  $1.024 \times 10^6\ \text{bits s}^{-1}$ .

- (i) Calculate the time taken to broadcast a 128 byte signal.

time required ..... s [2]

- (ii) The satellites travel at about  $4000\ \text{ms}^{-1}$ . Explain why it is essential that 'a GPS receiver also contains data tables which allow it to predict accurately the position of each satellite at any one time' (lines 115–116 in the article).

[1]

- (c) Fig. 7.2 shows three satellites **A**, **B** and **C** broadcasting signals to a single GPS receiver **R**, viewed from a point above the three satellites.

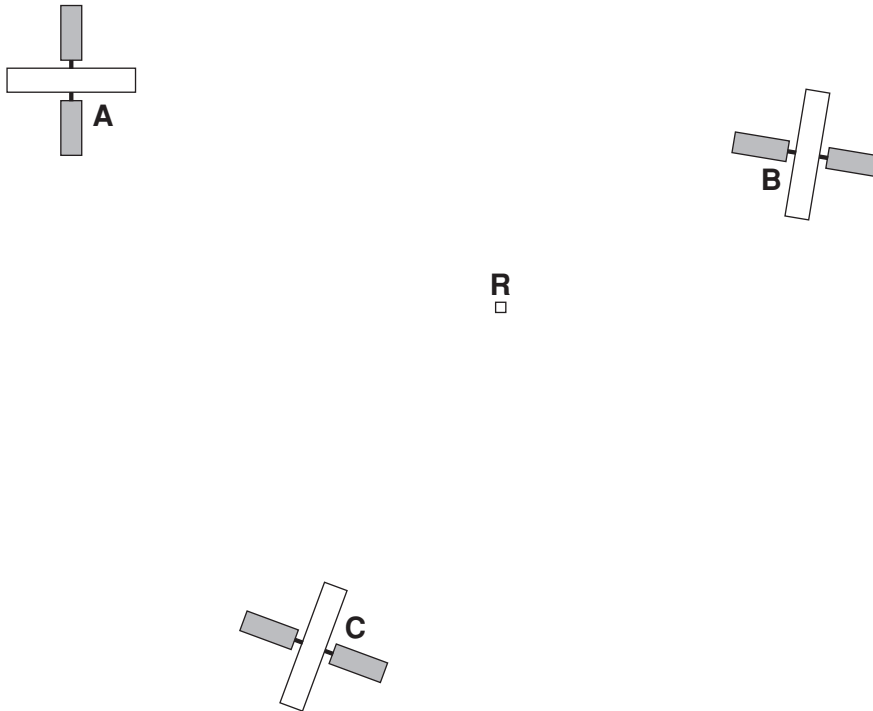

Fig. 7.2

not to scale

- (i) Explain why the position of the receiver **R** in Fig. 7.2 could not be found from the signals from satellites **A** and **B** alone.

[1]

- (ii) GPS systems use four satellites (lines 110–112 in the article) to locate the position of the receiver **R**.  
Suggest what extra information about position is given by the fourth satellite.

[1]

[Total: 8]

## Section B

- 8 This question is about small-scale electricity generation (micro-generation) which may become more popular as fuel prices increase.

A three blade domestic wind turbine with a blade radius of 1 m, illustrated in Fig. 8.1, has been advertised as having output power of 1 kW in a wind speed of about  $40 \text{ km h}^{-1}$ .

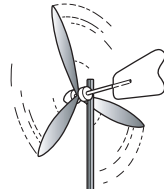

Fig. 8.1

- (a) Show that  $40 \text{ km h}^{-1}$  is about  $11 \text{ m s}^{-1}$ .

[2]

- (b) Fig. 8.2 shows the cylinder of moving air that could interact with the turbine blades in 1 second at a wind speed of  $11 \text{ m s}^{-1}$ .

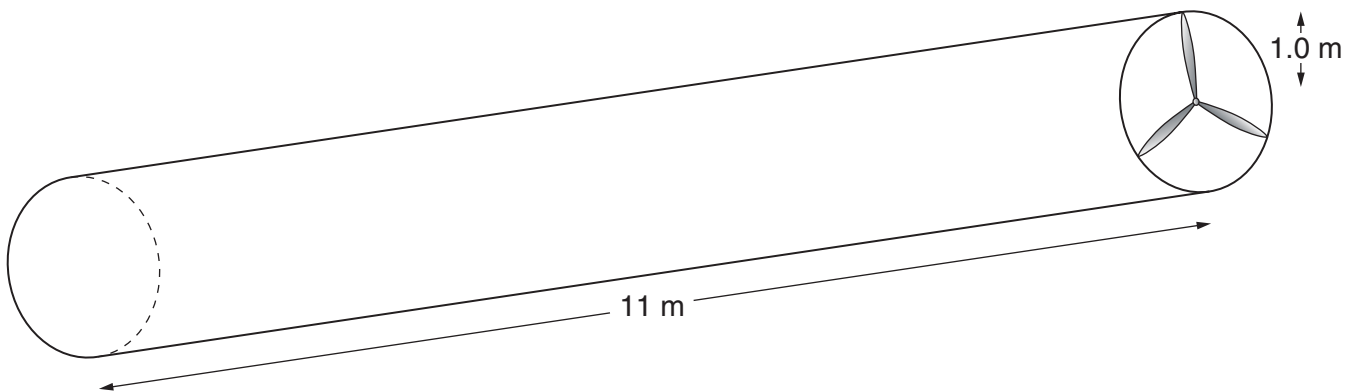

Fig. 8.2

- (i) Show that this cylinder of air contains about 40 kg of air.  
density of air =  $1.2 \text{ kg m}^{-3}$

[3]



(ii) Calculate the kinetic energy of the air passing through the turbine per second.

energy per second = ..... W [2]

(iii) Suggest why the output power of the wind turbine is much less than the value calculated in part (ii) above.

[2]

(c) Fig. 8.3 shows two vectors representing the momentum  $p_1$  of the air arriving at a turbine blade, and the momentum  $p_2$  after the air has been deflected by the blade in a small interval of time  $\Delta t$ .

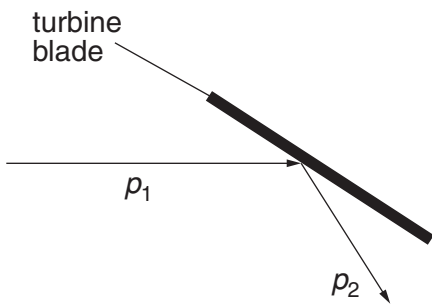

**Fig. 8.3**

(i) Draw, to the right of Fig. 8.3, a vector diagram showing the change in momentum of the air,  $\Delta p$ , in terms of  $p_1$  and  $p_2$ . [2]

(ii) Explain how the change in momentum of the air,  $\Delta p$  in the time  $\Delta t$  could be used to calculate the force acting on the turbine blade.

[2]

[Total: 13]

9 This question is about the design and performance of loudspeakers like that shown in Fig. 9.1.

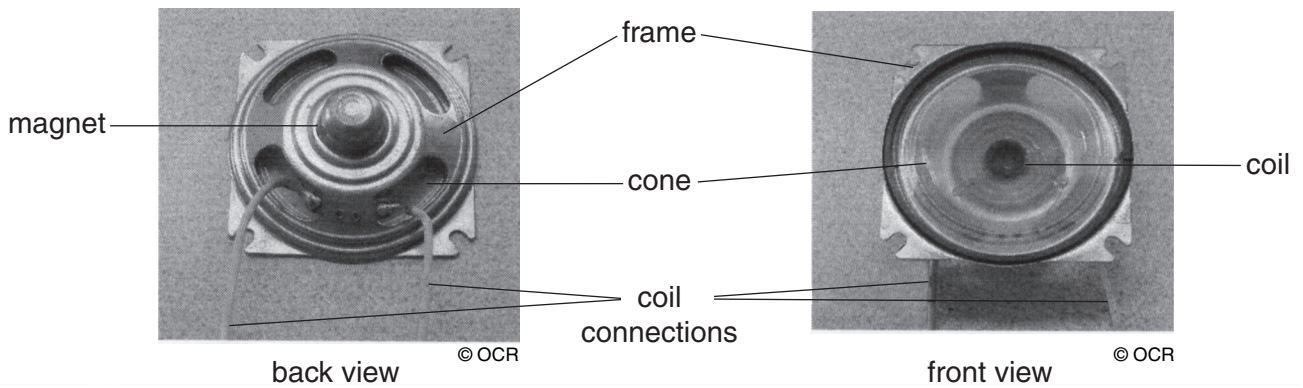

**Fig. 9.1**

(a) The loudspeaker contains a coil made of copper wire with a radius of 0.11 mm. It must have a resistance of  $8.0\Omega$ .

(i) Show that a length of about 20m of wire must be wound onto the coil.  
resistivity of copper,  $\rho = 1.7 \times 10^{-8}\Omega\text{m}$

[3]

(ii) Show that a p.d. of 1.0V will produce a current of about 130mA in the coil.

[2]

(b) Fig. 9.2 and Fig. 9.3 show sections through the speaker.

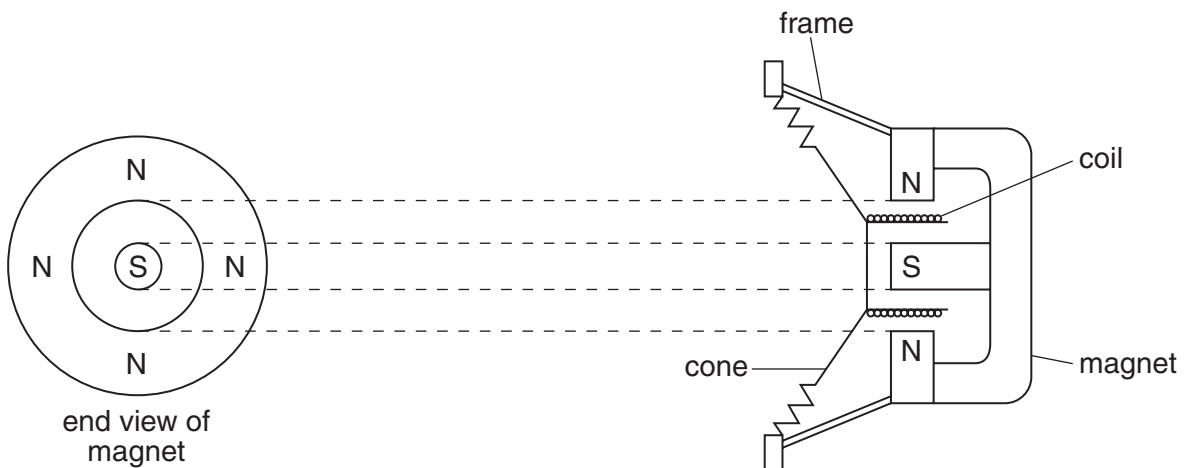

**Fig. 9.2**

**Fig. 9.3**

- (i) Draw four magnetic flux lines **on Fig. 9.2** to show the magnetic field shape in the gap in which the coil is placed.  
 Draw two complete flux loops **on Fig. 9.3** to show the magnetic circuits involved.
- [3]
- (ii) The magnetic field strength at the point where the coil is placed is 0.40T.  
 Calculate the magnetic force due to the 130 mA current in the coil.

[2]

- (c) Fig. 9.4 shows the loudspeaker placed in a removable baffle (a board with a hole in it).

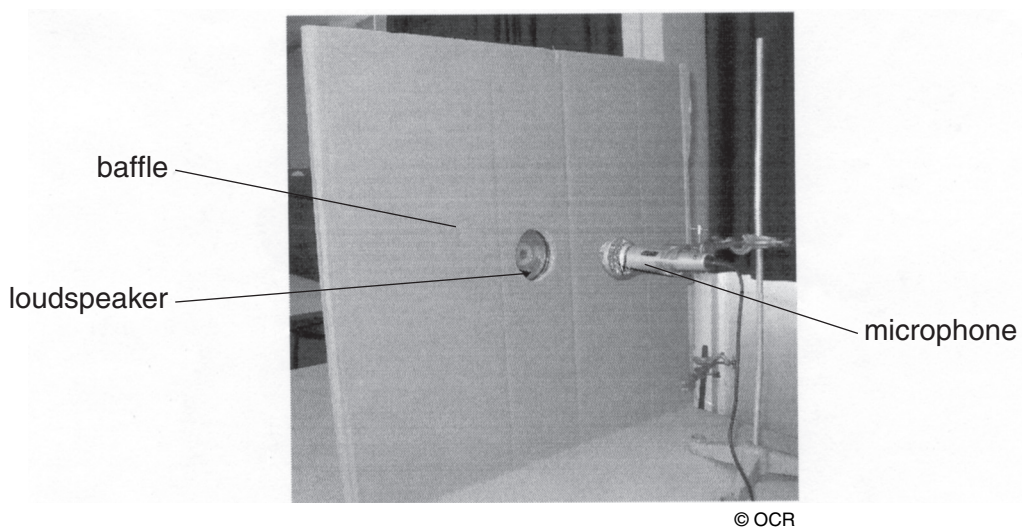

**Fig. 9.4**

The loudspeaker is supplied with a 600 Hz signal.

Suggest why the loudness of the signal detected by the microphone becomes **smaller** when the baffle is removed.

[2]

- (d) Placing the loudspeaker in certain positions in front of a wall can also increase the loudness of the signal detected by the microphone as shown in Fig. 9.5.

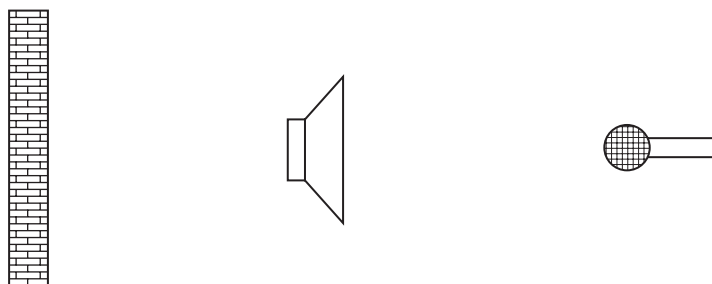

**Fig. 9.5**

Suggest how the presence of the wall can increase the loudness of the signal detected by the microphone.

[2]

[Total: 14]

[Quality of Written Communication: 4]

**END OF QUESTION PAPER**

21  
BLANK PAGE

PLEASE DO NOT WRITE ON THIS PAGE

**PLEASE DO NOT WRITE ON THIS PAGE**

**PLEASE DO NOT WRITE ON THIS PAGE**

**PLEASE DO NOT WRITE ON THIS PAGE**

---

Permission to reproduce items where third-party owned material protected by copyright is included has been sought and cleared where possible. Every reasonable effort has been made by the publisher (OCR) to trace copyright holders, but if any items requiring clearance have unwittingly been included, the publisher will be pleased to make amends at the earliest possible opportunity.

OCR is part of the Cambridge Assessment Group. Cambridge Assessment is the brand name of University of Cambridge Local Examinations Syndicate (UCLES), which is itself a department of the University of Cambridge.