

# Space Time and Motion

Name \_\_\_\_\_

Past Paper Questions from G492 June 2009 to June 2013

SA December 2016

## Equations given on data sheet

momentum

$$p = mv$$

impulse

$$F\Delta t$$

force

$$F = \frac{\Delta(mv)}{\Delta t}$$

work done

$$W = Fx \quad \Delta E = F\Delta s$$

power

$$P = Fv, \quad P = \frac{\Delta E}{t}$$

components of a vector in two perpendicular directions

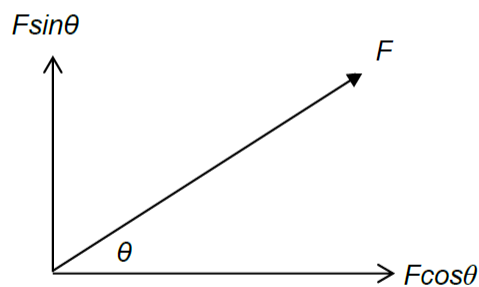

equations for uniformly accelerated motion

$$s = ut + \frac{1}{2}at^2$$

$$v = u + at$$

$$v^2 = u^2 + 2as$$

## Equations to learn

$$E_k = \frac{1}{2}mv^2$$

$$E_{\text{grav}} = mgh$$

$$F = ma$$

$$a = \frac{(v-u)}{t}$$

$$v_{\text{average}} = \frac{(v+u)}{2}$$

## Space, Time and Motion Specification

This section develops classical mechanics, including vectors. The conservation of momentum, the kinematics of uniformly accelerated motion and the dynamics of motion in two dimensions under a constant force are covered. IT skills may be developed through a variety of data capture techniques and simple mathematical modelling.

### (a) Describe and explain:

- (i) the use of vectors to represent displacement, velocity and acceleration
- (ii) the trajectory of a body moving under constant acceleration, in one or two dimensions
- (iii) the independent effect of perpendicular components of a force
- (iv) calculation of work done, including cases where the force is not parallel to the displacement
- (v) the principle of conservation of energy
- (vi) power as rate of transfer of energy
- (vii) measurement of displacement, velocity and acceleration
- (viii) Newton's laws of motion
- (ix) The principle of conservation of momentum; Newton's third law as a consequence.

### (b) Make appropriate use of:

- (i) the terms: displacement, speed, velocity, acceleration, force, mass, vector, scalar, work, energy, power, momentum, impulse and by sketching and interpreting:
- (ii) graphs of accelerated motion; slope of displacement-time and velocity-time graphs; area underneath the line of a velocity-time graph
- (iii) graphical representation of addition of vectors and changes in vector magnitude and direction.

### (c) Make calculations and estimates involving:

- (i) the resolution of a vector into two components at right angles to each other
- (ii) the addition of two vectors, graphically and two perpendicular vectors algebraically
- (iii) the kinematic equations for constant acceleration derivable from:  
 $a = (v-u)/t$  and average velocity  $= (v+u)/2$        $v = u + at$        $s = ut + \frac{1}{2} at^2$        $v^2 = u^2 + 2as$
- (iv) momentum  $p = mv$
- (v) the equation  $F = ma = \Delta(mv)/\Delta t$  where the mass is constant (recall  $F=ma$ )
- (vi) the principle of conservation of momentum (one dimensional problems only)
- (vii) work done  $\Delta E = F\Delta s$  and  $\Delta E = F\Delta s \cos \theta$  where  $F$  is at angle to displacement  $s$
- (viii) kinetic energy  $= \frac{1}{2} mv^2$  (recall)
- (ix) gravitational potential energy  $= mgh$  (recall)
- (x) force, energy and power: power  $= \Delta E/t$  and power  $= Fv$
- (xi) modelling changes of displacement and velocity in small discrete time steps, using a computational model or graphical representation of displacement and velocity vectors. (for constant force)

### (d) Demonstrate and apply knowledge and understanding of the following practical activities

- (i) investigating the motion and collisions of objects using trolleys, air-track gliders etc. with data obtained from ticker timers, light gates, data-loggers and video techniques
- (ii) determining the acceleration of free fall, using trapdoor and electromagnet arrangement, light gates or video technique
- (iii) investigating terminal velocity with experiments such as dropping a ball-bearing in a viscous liquid or dropping paper cones in air.

1 Here is a list of physical quantities.

force            kinetic energy            mass            power            velocity

(a) Which one can be measured in  $\text{Js}^{-1}$ ?

.....

(b) Which of the quantities are vectors?

..... [3]

3 A bee of mass 120mg flies at a speed of  $3.0\text{ms}^{-1}$ .

Calculate its kinetic energy.

kinetic energy = ..... J [2]

4 A ball is thrown out of a window 18m above the ground.

It is thrown horizontally at  $5.0\text{ms}^{-1}$ .

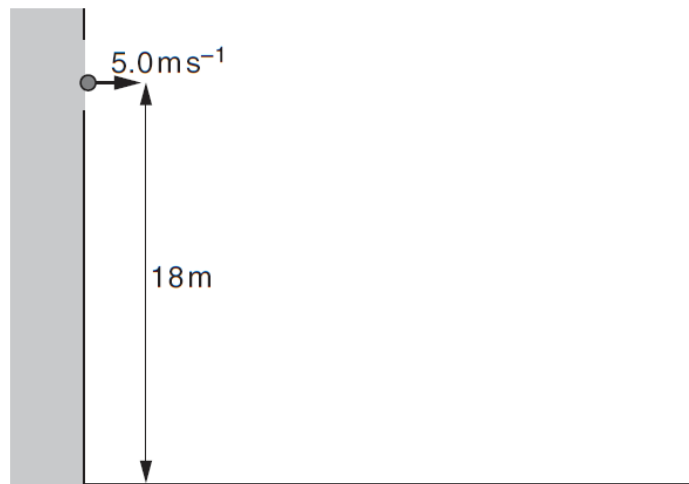

(a) Show that it takes about 2 seconds to reach the ground.

$$g = 9.8\text{ms}^{-2}$$

[2]

(b) Calculate the distance from the bottom of the building to the place where the ball hits the ground.

distance = ..... m [1]

10 This question is about trains on the London underground rail system.

(a) Fig. 10.1 shows two maps of the same part of the London underground.

Fig. 10.1A is part of the 'traditional' tube map that is used by travellers every day. Fig. 10.1B shows the actual positions of the stations and rail track.

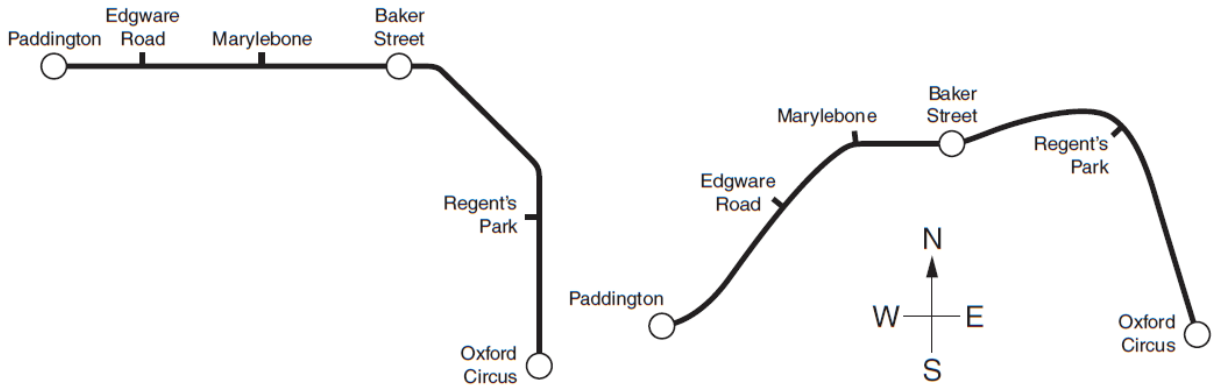

Fig. 10.1A

Fig. 10.1B

Fig. 10.1

(i) The average speed of the train between stations is fairly constant. Explain how a passenger travelling from Paddington to Marylebone could tell that Edgware Road is actually closer to Marylebone (Fig. 10.1B) than to Paddington (Fig. 10.1A).

[1]

(ii) Fig. 10.1A shows that the track between Baker Street and Regent's Park consists of three straight line segments joined by quite sharp curves.

A passenger, who is not able to see out of the window, is travelling between these stations at a steady speed. Suggest and explain how she could tell that the continuous curve of Fig. 10.1B is actually the correct arrangement.

[2]

(iii) Suggest why the 'traditional' tube map of Fig. 10.1A has remained popular since its design by Harry Beck in 1933, even though it is not an accurate representation of the positions of the stations and the directions of the lines.

[1]

- (b) Many of the stations on the London underground rail system are higher than the track either side of the station (Fig. 10.2).

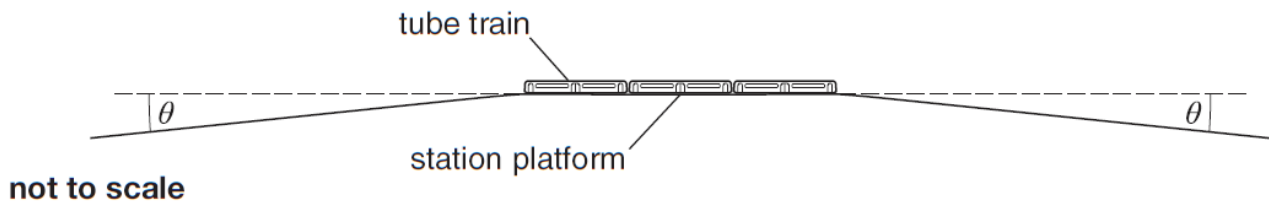

**Fig. 10.2**

- (i) The angle  $\theta$  between the track and the horizontal on each side of this station platform is  $1^\circ$ .

Show that the component of the train's weight acting parallel to the track when approaching or leaving the station is about one-fiftieth of its weight.

You may draw a vector diagram to help your answer.

[2]

- (ii) Describe the effect of this force on the motion of the train when approaching, and when leaving, the station.

[2]

- (iii) At each station the train has to stop and then start again. Explain why the arrangement of Fig. 10.2 wastes less energy, as compared with having the station on a perfectly level track.

[2]

11 This question is about satellite observations of the level of the oceans.

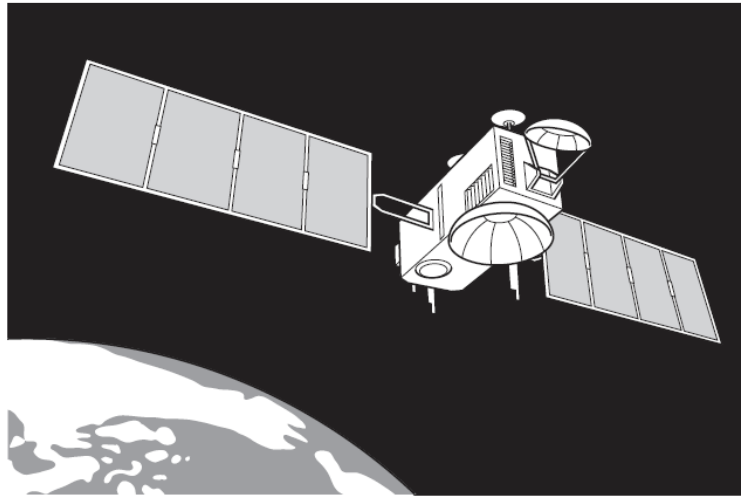

Fig. 11.1

The satellite Jason-1 observes water levels by reflecting microwaves off the ocean surfaces.

- (a) The satellite orbits at a height of  $1.3 \times 10^6$  m above the Earth's surface and completes an orbit in 1.9 hours (6800 s).

radius of the Earth =  $6.4 \times 10^6$  m

- (i) Show that the satellite is moving at a speed of about  $7 \text{ km s}^{-1}$ .

[3]

- (ii) Calculate the distance moved by the satellite in the time it takes for a pulse of electromagnetic radiation to go from the satellite to the ocean surface and back again.

speed of electromagnetic radiation,  $c = 3.0 \times 10^8 \text{ m s}^{-1}$

distance = ..... m [2]

- 1 The following five expressions are combinations of quantities used in AS physics. The variables shown by letters have their usual meanings.

$hf$        $Fv$        $\frac{1}{2}mv^2$        $d \sin \theta$        $\frac{1}{2}at^2$

(a) Which **two** expressions are used to calculate an energy?  
 ..... [1]

(b) Which **two** expressions are used to calculate a distance?  
 ..... [1]

- 3 A small aircraft flies at a velocity of  $200 \text{ km h}^{-1}$  relative to the ground.

There is a wind blowing at  $50 \text{ km h}^{-1}$  from the west.

The pilot wishes to reach a destination due north of the starting point.

Find the resultant speed  $v$  of the aircraft, and the angle  $\theta$ , west of north, which it must take.

Show your working clearly.  
 You may wish to draw a vector diagram.

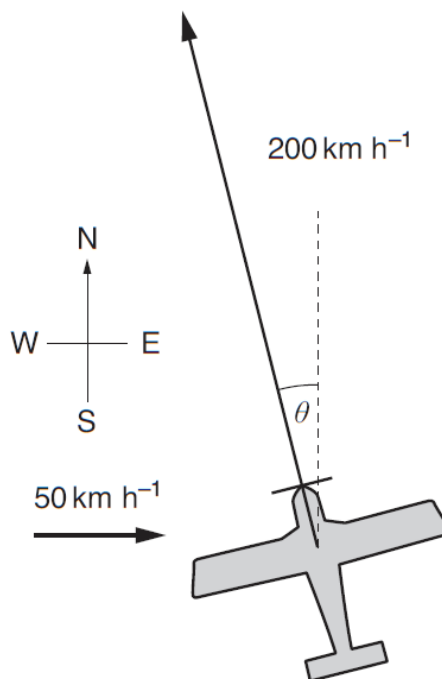

$v = \dots\dots\dots \text{ km h}^{-1}$   
 $\theta = \dots\dots\dots^\circ \text{ W of N [3]}$



- 4 The velocity-time graph below is for an object undergoing constant acceleration  $a$ .

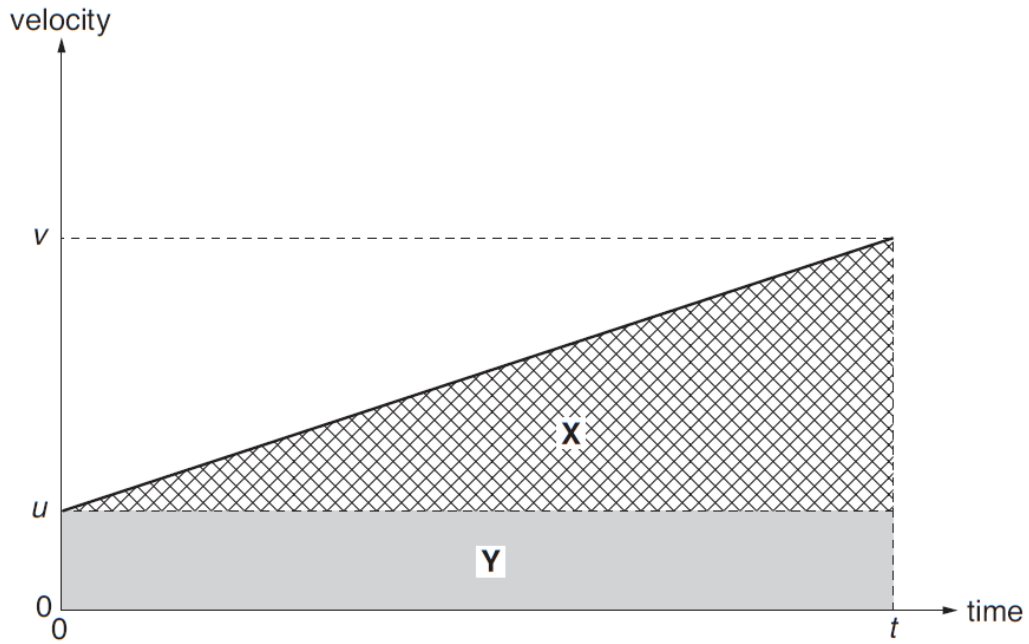

Which of the following statements about the areas **X** and **Y** are correct?

Put ticks (✓) in the **two** correct boxes.

$\mathbf{X} = ut$

$\mathbf{X} = \frac{1}{2}ut$

$\mathbf{X} = \frac{1}{2}at^2$

$\mathbf{Y} = ut$

$\mathbf{Y} = \frac{1}{2}vt$

$\mathbf{Y} = \frac{1}{2}at^2$

[2]

- 7 A popular toy has a plastic 'head' and a circular base fixed at each end of a spring. When the spring is compressed and then released, the toy jumps into the air.

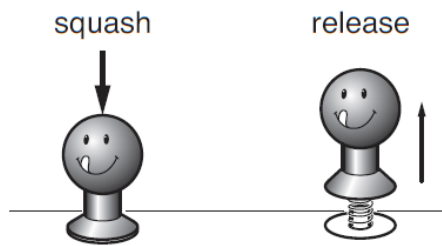

- (a) The mass of the toy is  $6.0 \times 10^{-3}$  kg.  
Calculate the minimum energy that must be stored in the spring for the toy to jump 0.50 m into the air.

$$g = 9.8 \text{ ms}^{-2}$$

energy = ..... J [2]

- (b) When the toy is squashed, the spring is compressed from a length of 30 mm to a length of 9 mm.  
The **average** force applied to compress the spring is 3 N.  
Calculate the work done in compressing the spring.

work done = ..... J [3]

- 8 In the 2008 Beijing Olympics, the Jamaican sprinter Usain Bolt won both the 100 metres and 200 metres races in record times.

Fig. 8.1 is the velocity-time graph for Usain in one of these two races.

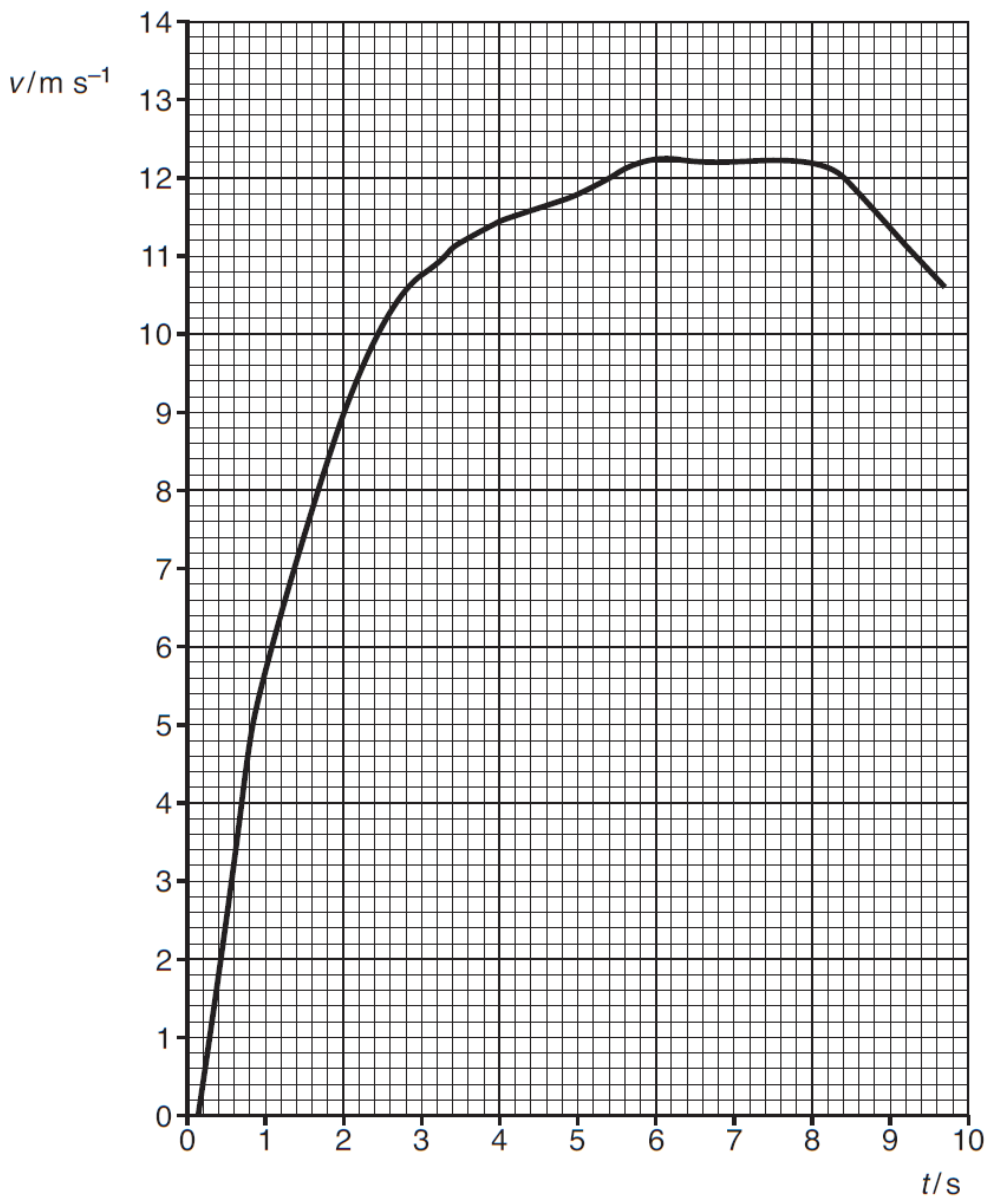

Fig. 8.1

- (a) (i) The starting gun was fired at the time  $t = 0$ .  
Use the graph to estimate Usain's reaction time to the starting gun.

reaction time = ..... s [1]

(ii) Use data from both axes of the graph to show that this was the 100m race.

[2]

(b) (i) Use the graph to estimate the horizontal force with which Usain pushed back on the starting block as he began to run.

mass of Usain Bolt = 88kg

force = .....N [3]

(ii) Explain why this answer cannot be more than an estimate.

[1]

(c) Commentators describing this race noted that Usain seemed to relax once he knew he could not be passed, and that this happened about 20 metres from the end. Use data from the graph to check this statement.



*You should ensure that you use data from the graph and explain your findings clearly.*

[3]

- 11 This question is about a computational model for the path of a projectile thrown horizontally at a speed of  $5 \text{ m s}^{-1}$ .  
In this model, equal time intervals of 0.2 seconds are used.

(a) Explain why the horizontal displacement  $\Delta x$  during each time interval is constant at 1.0 m.

[2]

(b) The computer program for the model produces the graph of Fig. 11.1.

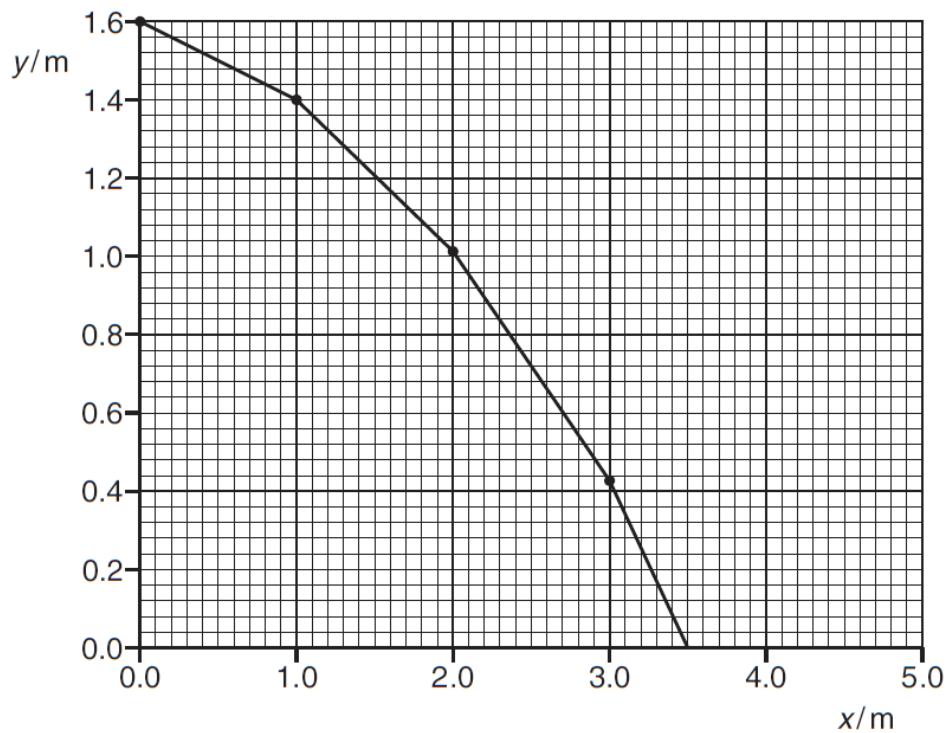

Fig. 11.1

- (i) The model makes the assumption that the vertical component of velocity does not change during each time interval.  
Explain clearly how the graph shows this.

[2]

- (ii) State how the graph shows that the projectile should hit the ground at about 0.7 s after it is thrown.

[2]

- (iii) Do a calculation to show that the time taken for a real object to fall vertically from rest through a distance of 1.6 m is significantly less than 0.7 s.

$$g = 9.8 \text{ ms}^{-2}$$

[2]

- (iv) The answers to (ii) and (iii) above show that the computational model produces vertical components of velocity which are too small. Explain why this is the case.

[1]

- (c) Suggest and explain a change which could be made to the model to produce a graph which more accurately matches the curve produced by a real projectile.

[2]

1 Here is a list of units.

$\text{Js}^{-1}$

$\text{Nkg}^{-1}$

$\text{Jm}^{-1}$

$\text{Nm}$

$\text{Js}$

Choose the correct unit for

(a) power

..... [1]

(b) acceleration.

..... [1]

2

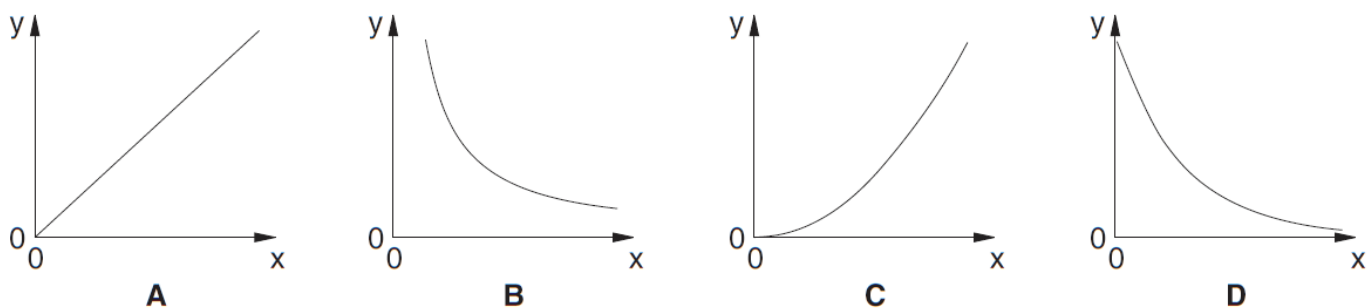

Fig 2.1

Which graph, **A**, **B**, **C** or **D** in Fig. 2.1, is obtained when the y and x axes represent the two quantities given in each case below?

(a) y-axis: the potential energy gained when an object is lifted  
x-axis: the vertical height through which it is lifted

..... [1]

(b) y-axis: the kinetic energy of a moving object  
x-axis: the speed of the object

..... [1]

(c) y-axis: the energy of a photon of electromagnetic radiation  
x-axis: the wavelength of the radiation

..... [1]

**6** A high-performance car has an acceleration of  $0.86g$ .

**(a)** Calculate the time it takes to reach a velocity of  $27\text{ ms}^{-1}$  ( $60\text{ miles hour}^{-1}$ ).

$$g = 9.8\text{ ms}^{-2}$$

time = ..... s **[2]**

**(b)** The car can brake from  $27\text{ ms}^{-1}$  to rest in a distance of  $35\text{ m}$ .  
Calculate the mean force exerted by the brakes.

$$\text{mass of car} = 1600\text{ kg}$$

mean force = ..... N **[2]**



- 7 When heavy barrels are unloaded off a lorry, they are dropped onto a thick mat to stop them breaking open when hitting the ground.  
The mat compresses from a thickness of 30cm to a thickness of 6.0cm.  
This decelerates the barrel.

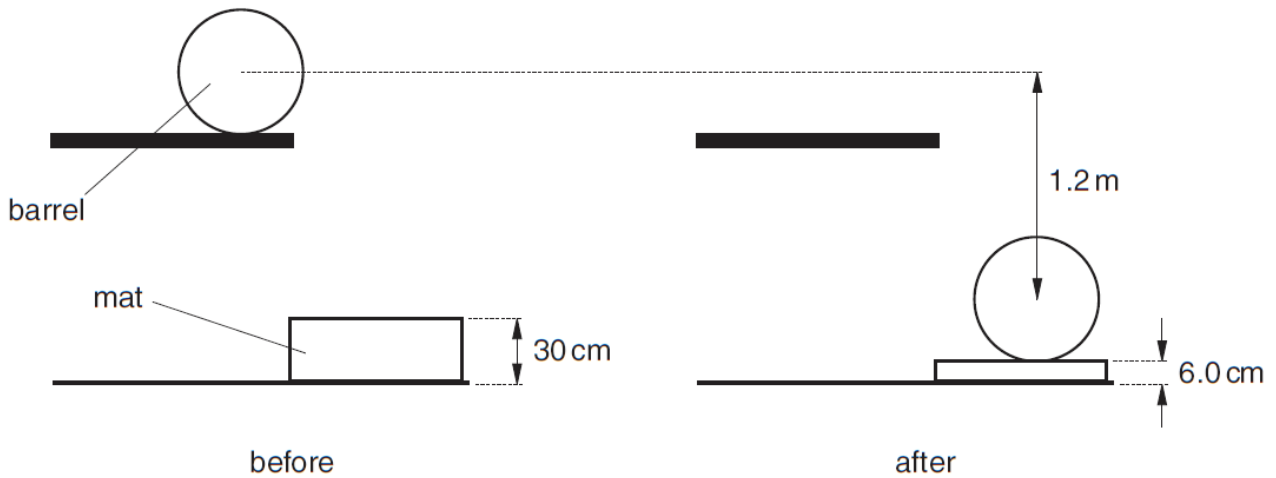

- (a) Show that the work that must be done to decelerate a barrel to rest after it has fallen 1.2 m is about 1.3 kJ.

mass of barrel = 110 kg  
 $g = 9.8 \text{ m s}^{-2}$

[2]

- (b) Calculate the mean force exerted by the mat to decelerate the barrel to rest.

Assume that no energy is lost before the barrel hits the mat.

mean force = ..... N [2]

- 8 This question is about forces on a helium party balloon.  
A helium balloon rising in the air has more than one force acting on it.

Besides weight, there is upthrust.

The upthrust is equal in magnitude to the weight of the air which would have occupied the volume taken up by the balloon.

When the balloon is moving there is also air resistance.

- (a) Fig. 8.1 shows a helium party balloon.

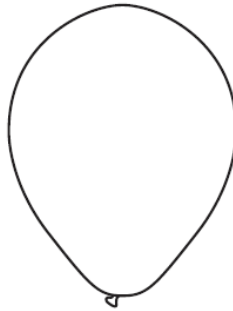

Fig. 8.1

On Fig. 8.1, draw three arrows, labelled **W**, **U** and **AR**, to show the directions of the weight, the upthrust and the air resistance acting on this balloon **as it rises through the air**. [1]

- (b) The balloon is released at time  $t = 0$ .

- (i) Explain why the air resistance force **AR** is zero at time  $t = 0$ .

[1]

- (ii) Use the data below to show that the resultant force acting on the balloon at time  $t = 0$  is about 0.02 N. Show your working clearly.

mass of rubber and helium = 0.0035 kg

mass of air taking up the same volume = 0.0060 kg

$g = 9.8 \text{ ms}^{-2}$

[2]

- (c) Air resistance forces increase as the balloon accelerates.

In a mathematical model to analyse the motion of the balloon, the air resistance force  $F_{\text{AR}}$  is given by

$$F_{\text{AR}} = kv$$

where  $v$  is the velocity of the balloon and  $k$  is a constant.

- (i) Suggest and explain one change to the balloon which would make the value of  $k$  **smaller**.



*In your answer you should use technical terms, spelled correctly.*

[2]

Using the mathematical model  $F_{AR} = kv$  with one particular value of  $k$  gives the graph in Fig. 8.2.

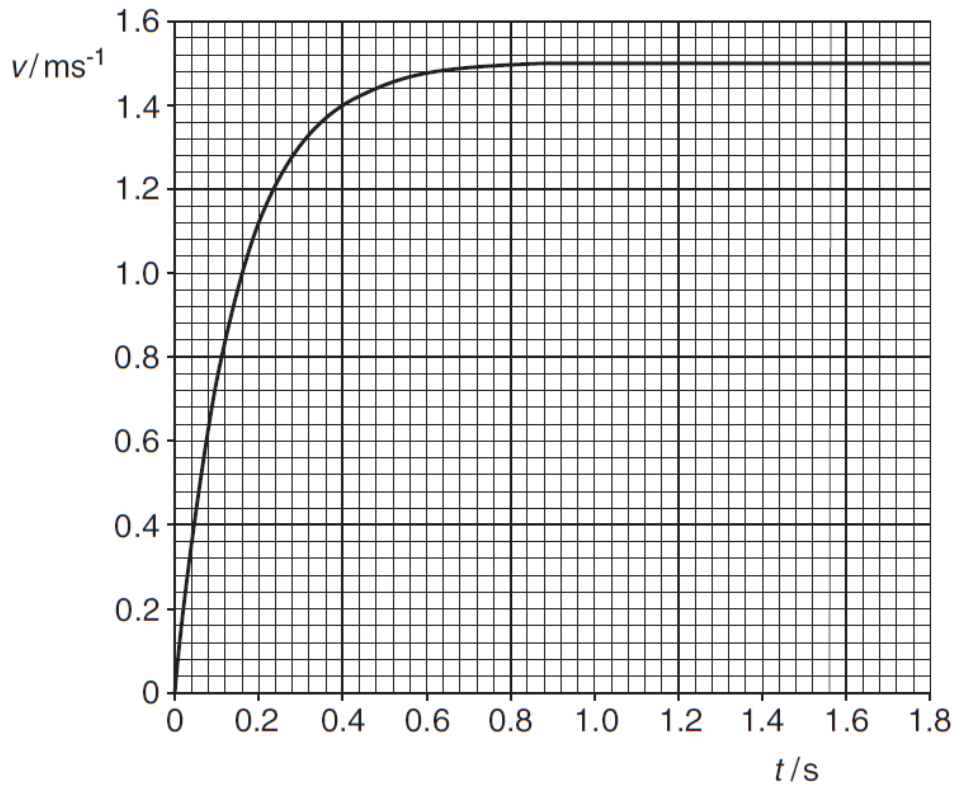

**Fig. 8.2**

(ii) Explain why the graph becomes less steep, and eventually horizontal, as time increases.

[2]

(iii) Fig. 8.2 shows that the velocity reaches a maximum of  $1.5\text{ m s}^{-1}$ . Show that this is consistent with a value of  $k = 0.016\text{ N s m}^{-1}$ .

[2]

11 This question is about a sport called kitesurfing (Fig. 11.1).

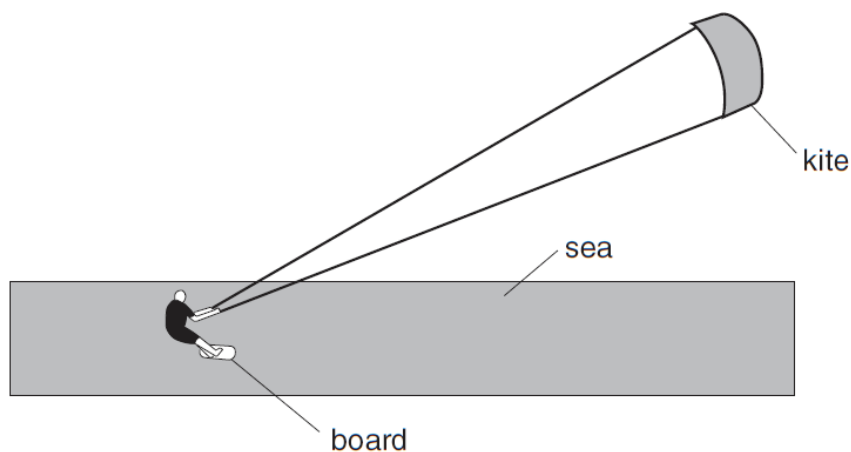

Fig. 11.1

The kitesurfer stands on the board, and is pulled along the surface of the sea by the lines attached to the kite.

The kitesurfer, lines and board are modelled in the diagram in Fig. 11.2.

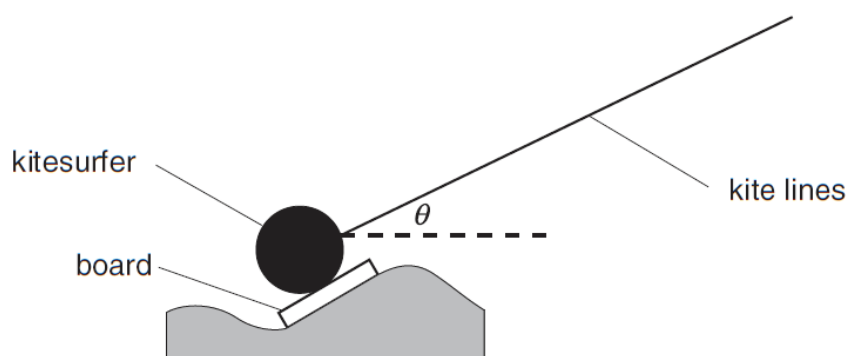

Fig. 11.2

- (a) The total tension in the kite lines is 1000 N.  
By scale drawing or calculation, show that, when the angle  $\theta = 30^\circ$ , the horizontal force pulling the kitesurfer is about 900 N.

[3]

- (b) (i) Explain why the kitesurfer in this situation needs to have a mass of more than 51 kg. Your answer should refer to the components of forces.

$$g = 9.8 \text{ m s}^{-2}$$

[2]

- (ii) A kitesurfer usually takes a selection of kites of different sizes to the water. Suggest and explain the reason for this.

[2]

- (c) The kitesurfer is pulled along horizontally at a **steady speed** by the force described in part (a). State what this tells you about the forces between the board and the water. You should refer to components of forces in your answer.

[2]

1 Here is a list of equations used to calculate the quantities  $F$ ,  $W$ ,  $P$ ,  $v^2$  and  $s$  in certain situations.

$$F = ma \qquad W = F\Delta s \qquad P = Fv \qquad v^2 = u^2 + 2as \qquad s = ut + \frac{1}{2}at^2$$

(a) Which of the quantities  $F$ ,  $W$ ,  $P$ ,  $v^2$  and  $s$  could be measured in J?  
 ..... [1]

(b) Which of the quantities  $F$ ,  $W$ ,  $P$ ,  $v^2$  and  $s$  are vectors?  
 ..... and ..... [1]

7 A stone is thrown vertically upwards at  $12 \text{ m s}^{-1}$ .

(a) Calculate the speed  $v$  of the stone when it is  $3.0 \text{ m}$  above the point of projection.

$$g = 9.8 \text{ m s}^{-2}$$

$$v = \dots \text{ m s}^{-1} \text{ [3]}$$

(b) When the equation  $s = ut + \frac{1}{2}at^2$  is used to calculate the time taken to reach a point  $3.0 \text{ m}$  above the point of projection, two answers of  $0.28 \text{ s}$  and  $2.2 \text{ s}$  are obtained. Explain, without calculation, how the displacement can be the same at two different times.

[1]

- 9 In one extreme sport, BASE jumping, people jump off structures such as buildings or bridges. They open a parachute as late as they dare (Fig. 9.1).

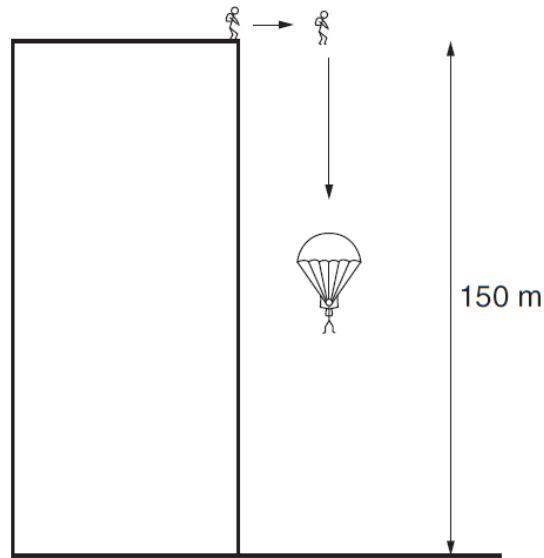

Fig. 9.1

- (a) In one BASE jump, the building used is 150 m high. In a simple model of the jump, a jumper accelerates uniformly with  $a = g$  before she opens her parachute.

- (i) Show that it takes a little over 1 s for the free-falling BASE jumper to reach a speed of  $12 \text{ ms}^{-1}$ .

$$g = 9.8 \text{ ms}^{-2}$$

[1]

- (ii) Show that the distance fallen by the BASE jumper before she reaches a speed of  $12 \text{ ms}^{-1}$  is about 7 m.

[2]



- (iii) Assume that her parachute opens instantly after the first 7 m of free-fall, and that she then falls at a steady speed of  $6.0 \text{ m s}^{-1}$  for the rest of the fall. Calculate the **total** time she takes to reach the ground.

total time = ..... s [2]

- (b) The graph for the jump described by the model in (a) is shown in Fig. 9.2.



Fig. 9.2

Sketch on Fig.9.2 the actual curve you would expect for the BASE jumper. When the parachute is opened, her terminal velocity is  $6.0 \text{ m s}^{-1}$ .

[2]

(c) The BASE jumper hits the ground at a speed of  $6.0 \text{ m s}^{-1}$ . On landing, she folds her legs and rolls over onto the ground.

(i) Explain why these actions make the landing safer.

[1]

(ii) Calculate the average resultant force on the BASE jumper during landing if the time taken from first touching the ground to being completely stopped is 0.25 s.

mass of BASE jumper = 53 kg

force = ..... N [2]

- 11 This question is about firing an arrow using a longbow.  
In Fig. 11.1, the archer has pulled back the bowstring to hold the arrow at rest with a force  $F$ . The tension in the bowstring is  $T$ .

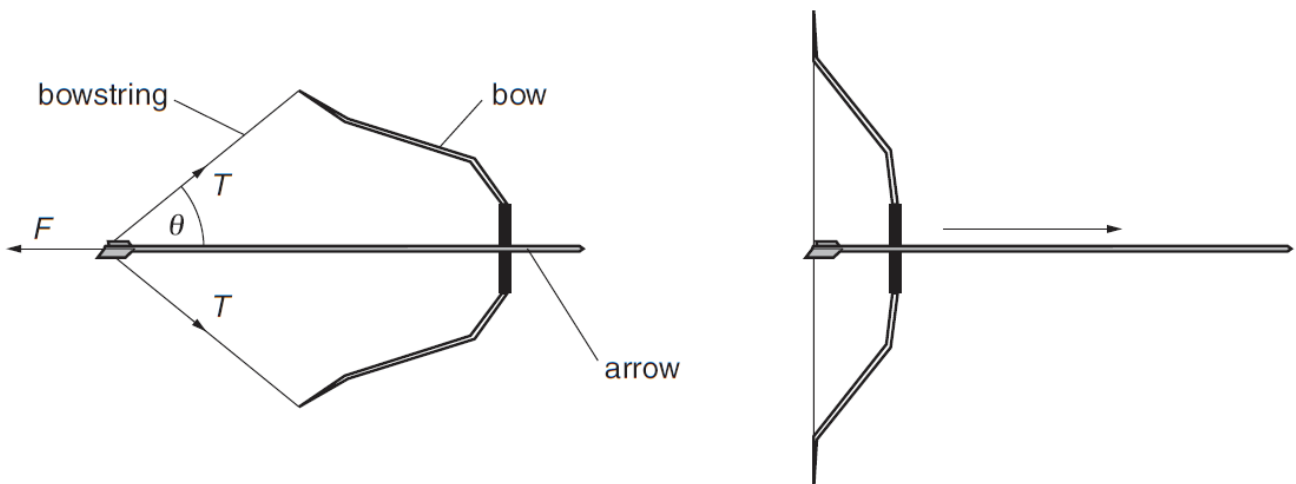

Fig. 11.1

- (a) (i) Explain why the horizontal component of  $T$  is equal to  $\frac{1}{2}F$ .

[2]

- (ii) When the archer is pulling back the bowstring with a force  $F$  of 140N, the angle  $\theta = 36^\circ$ .  
Show that the tension in the bowstring is about 90N.

[2]

(b) When the arrow is released, it is accelerated by the string over a distance of 0.80 m.

- (i) Assume the arrow is accelerated by an average force of 85 N.  
Calculate the kinetic energy gained by the arrow when it is released.

kinetic energy gained = ..... J [1]

- (ii) Explain why the accelerating force changes from 140 N as the bowstring moves forward.

In your answer, consider different factors which may affect the accelerating force, and how they change during the release of the arrow.



*You should organise your answer clearly and coherently.*

[3]

1 Here is a list of units.

$\text{Js}^{-1}$        $\text{kgms}^{-2}$        $\text{Js}$        $\text{Nm}$        $\text{Ws}$

(a) Choose the correct unit for force.

..... [1]

(b) Which two are units of energy?

..... and ..... [1]

2 Here is a list of magnitudes.

$10^{-9}$        $10^{-6}$        $10^{-3}$       1       $10^3$        $10^6$

(a) Choose the value closest to the wavelength of visible light in m.

..... [1]

(b) Choose the value closest to the weight of a person in N.

..... [1]

6 A car of mass 850 kg can accelerate from 0 to  $27 \text{ms}^{-1}$  in 15 s.

(a) Show that the mean accelerating force is about 1500 N.

[2]

(b) The car moves along a straight, horizontal road at a constant speed of  $27 \text{ms}^{-1}$ . The engine provides a constant driving force of 1100 N. Calculate the power dissipated against friction.

power = ..... W [1]

- 7 A treasure map states:
- from the palm tree, go 15 paces north,
  - then go 7 paces west
  - the treasure is buried 3 paces south.

By calculation or drawing, find the magnitude and direction of the displacement of the treasure from the palm tree.

The central dot represents the palm tree.

Each small square on the grid below represents one pace.

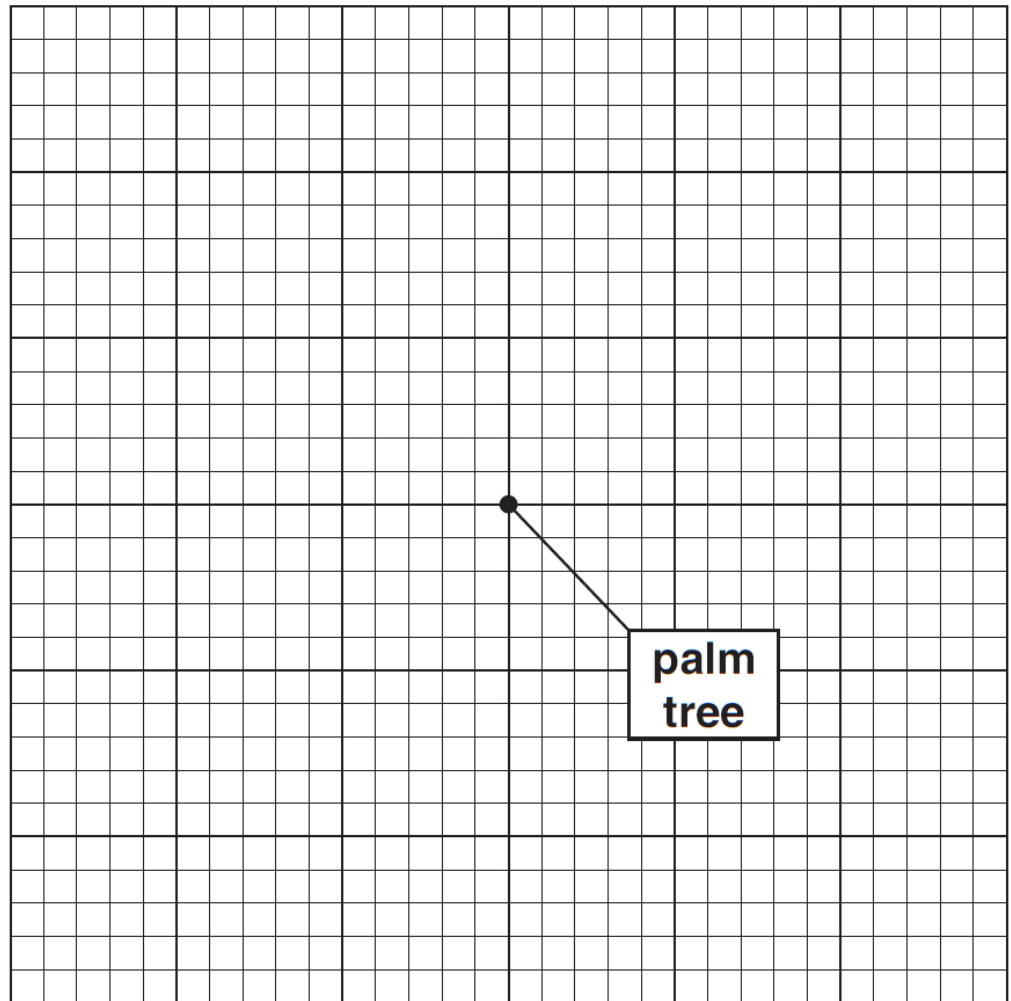
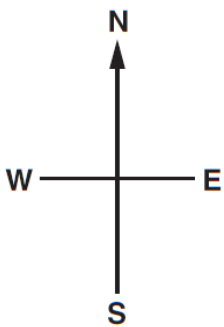

displacement = ..... paces

in a direction ..... [3]

- 9 This question is about a small rocket taking off. The rocket has a **constant** upward thrust  $T$  provided by the rocket engines, which work by ejecting gases at high velocity. As gas is ejected, the weight  $W$  of the rocket decreases.

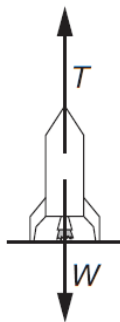

Fig. 9.1

The velocity-time graph for this rocket is shown in Fig. 9.2. The rocket engines start at time  $t = 0$  s.

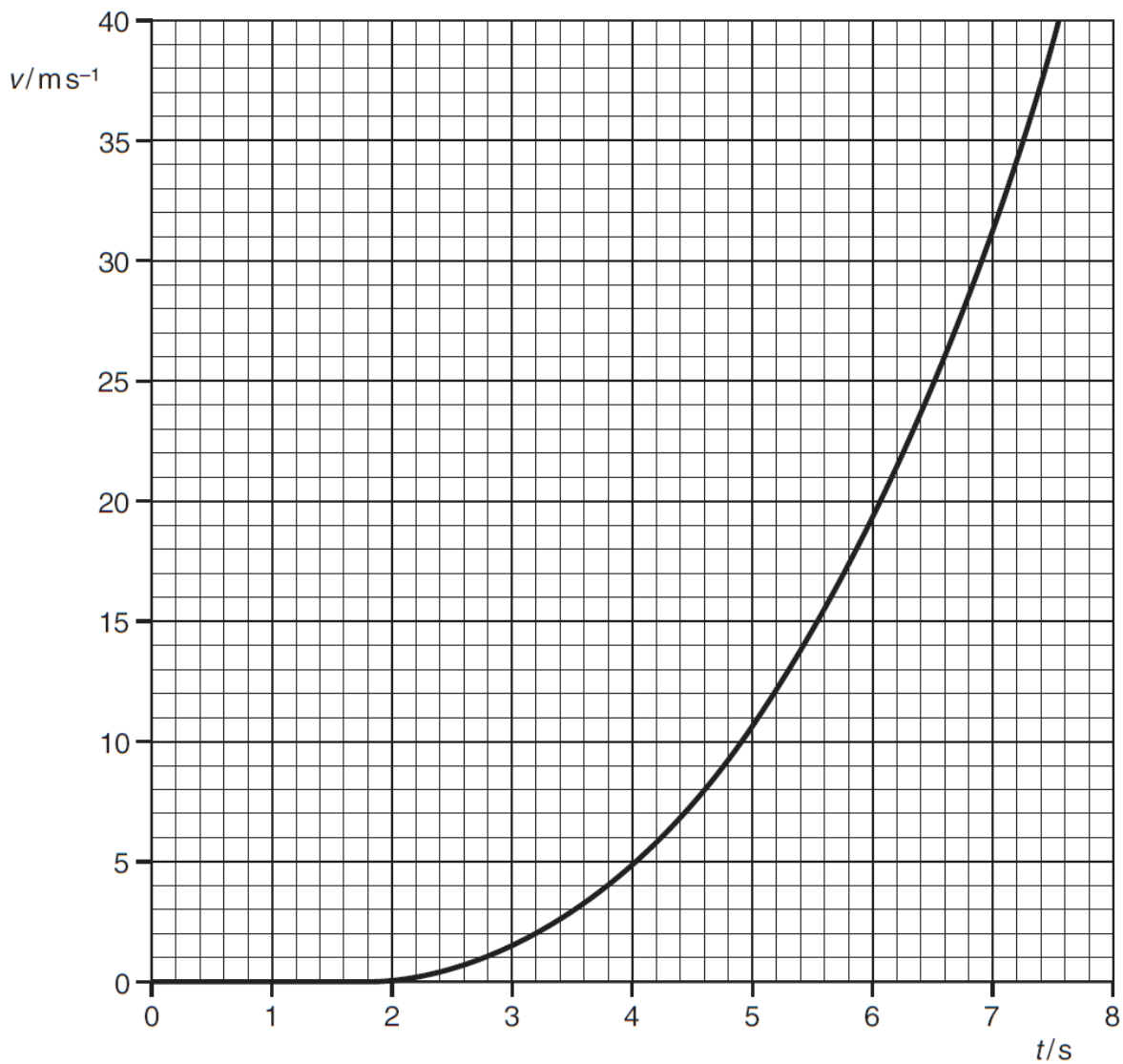

Fig. 9.2

- (a) (i) State how the graph of Fig. 9.2 shows that the rocket remains stationary for a short while after the rocket engines start.

[1]

- (ii) Explain in terms of the forces  $T$  and  $W$  why the rocket remains stationary for a short while, then begins to rise.

[2]

- (b) (i) Use the graph of Fig. 9.2 to show that the acceleration of the rocket at the time  $t = 6.0$  s is about  $10 \text{ m s}^{-2}$ .  
Show your working clearly on the graph and in this space.

[3]

- (ii) Show that at time  $t = 6.0$  s, the weight  $W$  of the rocket is about half the thrust  $T$  of the rocket engines.

$$\begin{aligned} \text{mass of rocket at this time} &= 6.9 \text{ kg} \\ g &= 9.8 \text{ m s}^{-2} \end{aligned}$$

[2]

- (c) On Fig. 9.2 opposite, sketch the graph you would expect if the rocket had taken off with a slightly greater mass of gas ejected each second, giving a slightly larger thrust,  $T$ .

[2]



- 11** This question is about the first measurement of the speed of light by the Danish astronomer Ole Rømer in 1676. He found that there were two times in the year when Jupiter and Io were at the same point in the sky, relative to the stars. The two positions of the Earth at these two times are shown as **A** and **B**, a distance  $d$  apart, in Fig. 11.1.

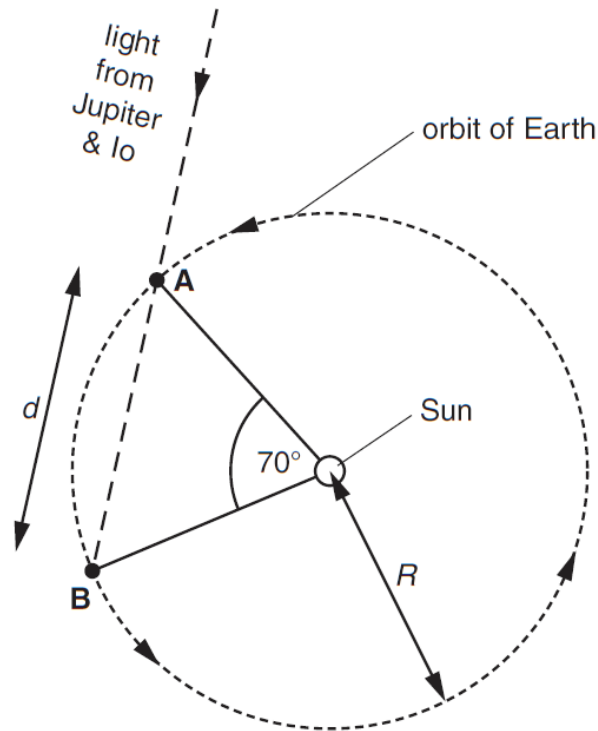

**Fig. 11.1**

- (a) (i) Use data from Fig. 11.1 to show that the Earth took 71 days to move from **A** to **B**.  
1 year = 365 days

[2]

- (ii) During the time it took the Earth to move from **A** to **B**, the moon Io made 40 orbits around Jupiter.  
Calculate the time for one orbit of Io in minutes.

time = ..... minutes [2]

(b) Knowing the time for one orbit of Io, Rømer was able to calculate that the time taken for light to travel from **A** to **B** was 11 minutes.

(i) Use the geometry of Fig. 11.1 to show that

$$d = 2R \sin(35^\circ)$$

where  $R$  is the radius of the Earth's orbit. Show your working clearly.

[2]

(ii) The radius  $R$  of the Earth's orbit was estimated in Rømer's time to be  $1.4 \times 10^{11}$  m. Use this value, together with the 11 minutes it took light to travel from **A** to **B**, to calculate the speed of light,  $c$ .

$$c = \dots\dots\dots \text{ms}^{-1} \text{ [2]}$$

(iii) Suggest and explain one reason why the value for  $c$  obtained in (ii) is too low.

[2]

- 12** This question is about a game in which each player must throw a hard wooden ball into a bucket so that the ball stays in the bucket.  
The thrower throws the ball, with initial velocity  $u$  at an angle  $\theta$  to the horizontal, towards a bucket as shown in Fig. 12.1. The ball enters the bucket after time  $t$ .

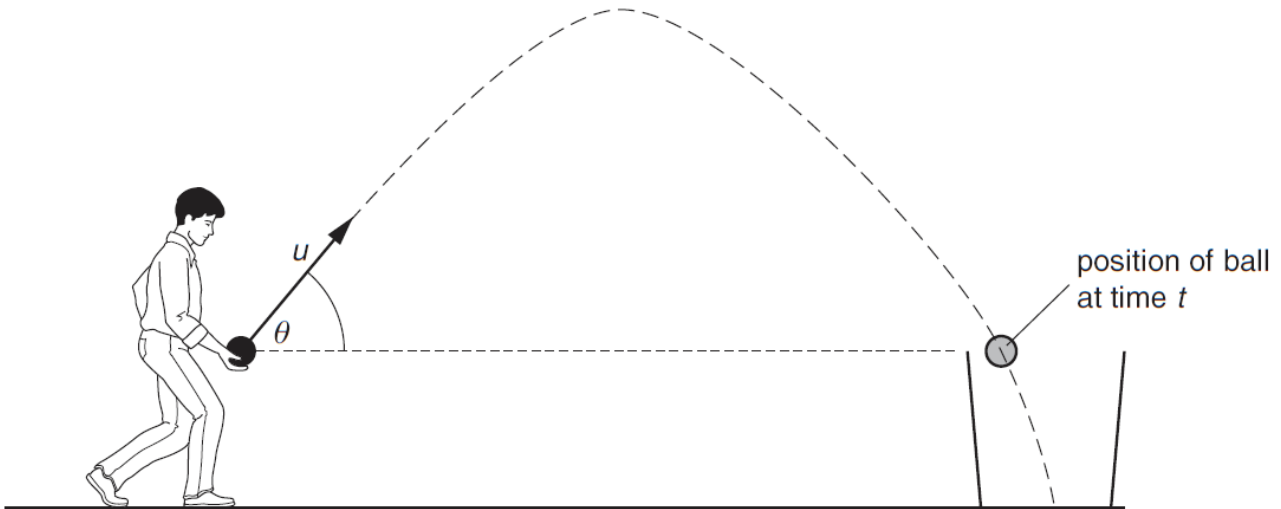

**Fig. 12.1**

- (a)** Write down expressions for the horizontal and vertical components of  $u$ .

horizontal component of  $u = \dots\dots\dots$

vertical component of  $u = \dots\dots\dots$  **[1]**

- (b)** The ball leaves the player's hand at the same height above the ground as the top of the bucket. The time  $t$  taken for the ball to reach the top of the bucket is given by the equation

$$0 = (u \sin \theta)t - \frac{1}{2}gt^2.$$

- (i)** Show that this equation arises from applying an equation for uniformly accelerated motion to the vertical motion of the ball.

**[3]**

- (ii) Calculate the time taken for a ball thrown at  $8.0\text{ m s}^{-1}$  at an angle of  $50^\circ$  to the horizontal to reach the top of the bucket.

$$g = 9.8\text{ ms}^{-2}$$

$t = \dots\dots\dots\text{ s}$  [3]

- (c) When the hard wooden ball, thrown as shown at an angle of  $50^\circ$  to the horizontal, hits the **bottom** of the bucket, some kinetic energy is dissipated during the collision, but the remaining kinetic energy is usually enough to allow the ball to bounce back out. Suggest and explain a strategy for **throwing** the given ball which might increase the chance of the ball staying in the bucket.

[2]

1 Here is a list of quantities.

**energy          force          power          speed          velocity**

(a) Which two quantities can have the same units?  
 ..... and ..... [1]

(b) Which two quantities are vectors?  
 ..... and ..... [1]

(c) Use two of the quantities to complete the following sentence.  
 ..... equals ..... divided by time. [1]

2

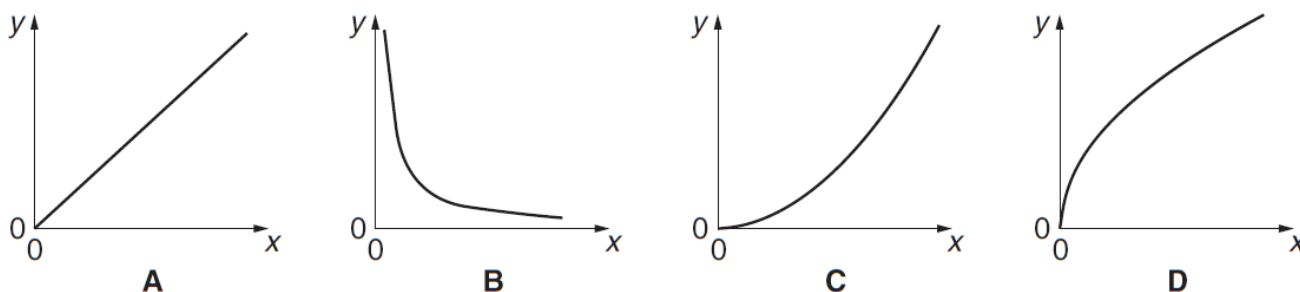

State which graph, **A**, **B**, **C** or **D**, best represents the relationship between the two quantities given in each case below.

(a) y-axis: the acceleration of an object  
 x-axis: the resultant force acting on that object  
 ..... [1]

(b) y-axis: the wavelength of a wave  
 x-axis: the frequency of that wave  
 ..... [1]

(c) y-axis: the kinetic energy of moving objects at a given speed  
 x-axis: the mass of each object  
 ..... [1]

(d) y-axis: the distance a free-falling object has fallen from rest  
 x-axis: the time it has been falling  
 ..... [1]

4 A ball of mass 0.5 kg is thrown vertically upwards with a speed of  $15 \text{ m s}^{-1}$ .

(a) Calculate the gravitational potential energy it has gained when it has risen 8.0 m.  
 $g = 9.8 \text{ m s}^{-2}$

gravitational potential energy gained = ..... J [1]

(b) Find its speed when it has risen 8.0 m. Assume there is no air resistance.

speed = .....  $\text{m s}^{-1}$  [3]

5 Fig. 5.1 shows two forces acting on an object. No other forces act on the object.



Fig. 5.1

The object has a mass of 2.6 kg.  
Calculate the acceleration of the object.

acceleration = .....  $\text{m s}^{-2}$  [2]

7 The graph shows the velocity of a stone being launched from a catapult.

The stone loses contact with the catapult at the point marked **X**.

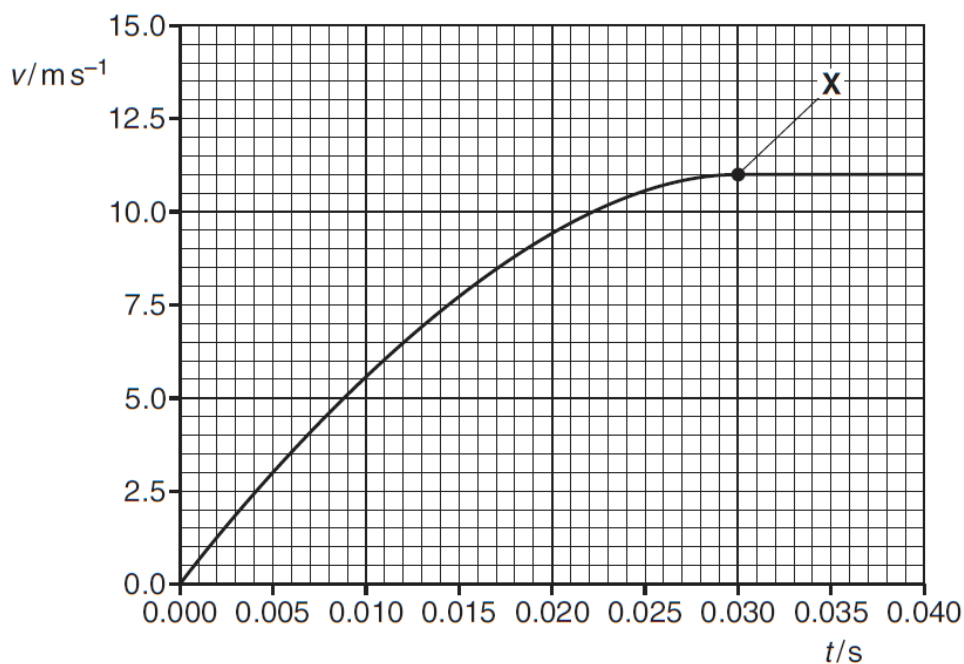

Use the graph to calculate the distance the stone moved while in contact with the catapult. Make your working clear on the graph and in this space.

distance = ..... m [3]

- 9 This question is about the performance of a small, low-powered car.



**Fig. 9.1**

- (a) In a test, the car accelerates from 0 to  $27\text{ m s}^{-1}$  (60mph) in 10.9s.
- (i) Show that the mean resultant force acting on the car during the acceleration is about 2 kN.

mass of car and driver = 860 kg

**[3]**

- (ii) In the acceleration test the driver was alone in the car.  
Explain the difference in the 0 to 60mph test you would expect if the driver were accompanied by a passenger.

**[2]**



**(b)** The car now travels at a constant speed of  $20\text{ m s}^{-1}$  along a straight, horizontal road.

**(i)** Explain why the force pushing the car forward must be equal in magnitude to the resistive force acting on the car.

[1]

**(ii)** In these conditions the useful mechanical output power from the car engine is 15 kW. Calculate the resistive force acting against the car.

force = ..... N [2]

**(iii)** At a constant speed of  $20\text{ m s}^{-1}$  on a straight, horizontal road, the car can travel for 18 km on 1 litre of fuel.

The fuel releases  $33\text{ MJ litre}^{-1}$  when burnt in the engine.

Show that at this speed the energy released per second by the fuel is nearly 40 kW.

[2]

**(iv)** Account for the difference between the values of power in **(ii)** and **(iii)**.

[1]

- 11 This question is about the vector nature of velocity and acceleration.  
 At time  $t = 0$ , an object is moving in the  $x$ -direction at  $5.0 \text{ ms}^{-1}$  as shown in Fig. 11.1.  
 Two seconds later, it is moving at  $40^\circ$  to that direction, but at the same speed.

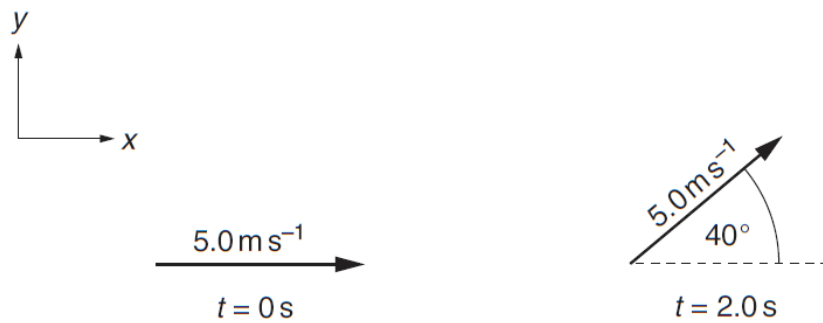

Fig. 11.1

- (a) (i) Show that the  $x$ -component of velocity at time  $t = 2.0 \text{ s}$  is about  $4 \text{ ms}^{-1}$  and that the  $y$ -component of velocity at this time is about  $3 \text{ ms}^{-1}$ .

[2]

- (ii) Show that the mean  $x$ -component of acceleration during the  $2.0 \text{ s}$  is about  $-0.6 \text{ m s}^{-2}$ .

[2]

- (b) The mean  $y$ -component of acceleration during the  $2.0 \text{ s}$  is  $+1.6 \text{ ms}^{-2}$ .

Choosing an appropriate scale, draw the two vector components of acceleration on the grid of Fig. 11.2 opposite and determine the magnitude and direction of the resultant acceleration.

magnitude of acceleration = .....  $\text{ms}^{-2}$

direction of acceleration = .....  $^\circ$

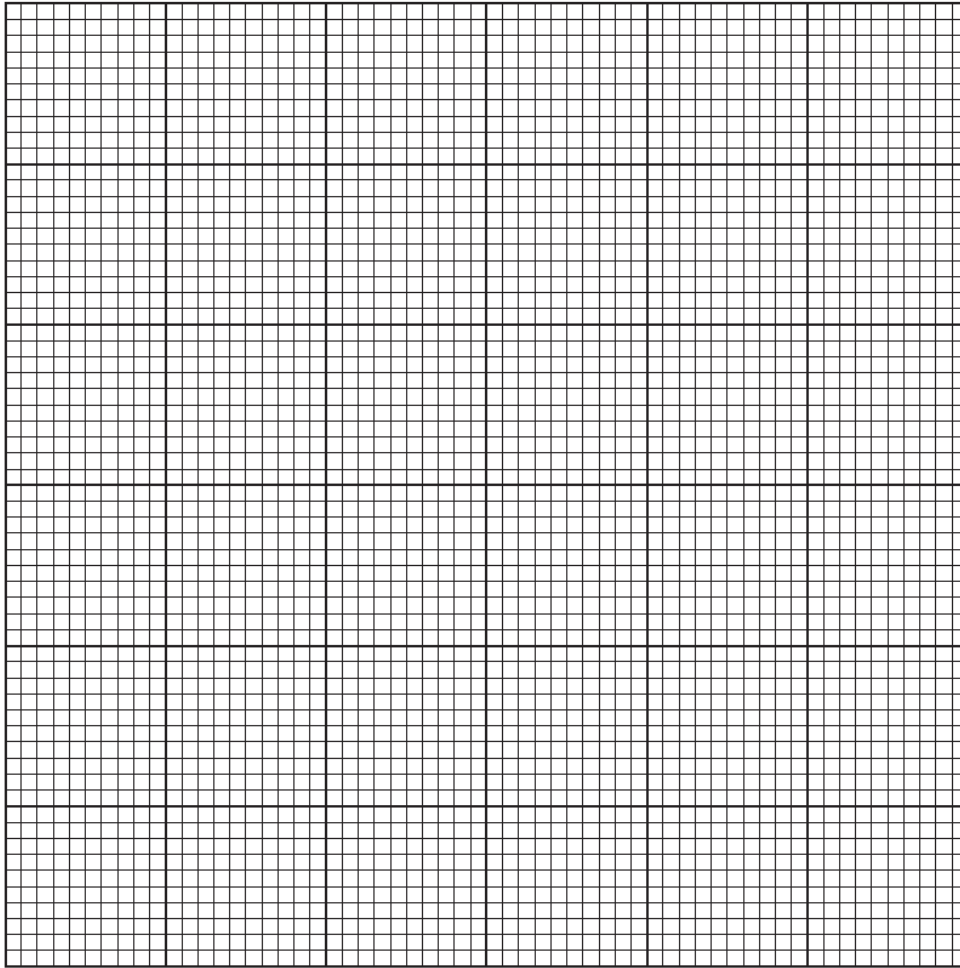

**Fig. 11.2**

[4]

- (c) The force which accelerated the object was at right angles to the direction of motion. Use the definition of **work** to explain why this force does no work on the object in this time.

[2]

1 The list below shows different orders of magnitude.

0.01            0.1            1            10            100            1000

(a) Choose the best estimate for the **width** of your arm in metres.

..... [1]

(b) Choose the best estimate for the mass of an adult man in kilograms.

..... [1]

2 Here is a list of units.

J            N m            W             $\text{kg m s}^{-2}$              $\text{N kg}^{-1}$

(a) Which two units are equivalent?

..... and ..... [1]

(b) Which is a unit for force?

..... [1]

(c) Which unit can be used for the acceleration due to gravity,  $g$ ?

..... [1]

3 In each of the four equations below,  $k$  is a constant.

$$y = kx$$

**A**

$$y = \frac{k}{x}$$

**B**

$$y = kx^2$$

**C**

$$y = k\sqrt{x}$$

**D**

Which is the correct equation, **A**, **B**, **C** or **D**, when  $y$  and  $x$  represent the two quantities given in each case below?

- (a)  $y$ : the frequency of an electromagnetic wave in a vacuum  
 $x$ : the wavelength of that wave

..... [1]

- (b)  $y$ : the distance travelled by an object accelerating uniformly from rest  
 $x$ : the time that the object has been moving

..... [1]

- (c)  $y$ : the speed of an object dropped from rest in a vacuum  
 $x$ : gravitational potential energy lost to reach that speed

..... [1]

4 A 1200 kg car slows down with a constant deceleration of  $1.8 \text{ ms}^{-2}$ .

- (a) Calculate the resultant force acting on the car during the deceleration.

force = ..... N [1]

- (b) Calculate the distance it travels during deceleration when it slows down from  $30 \text{ ms}^{-1}$  to  $13 \text{ ms}^{-1}$ .

distance = ..... m [2]

10 This question is about the vector nature of displacement, velocity and acceleration.

- (a) An object moves in the  $x$ - $y$  plane along a semi-circular path from **A** to **C** as shown in Fig. 10.1. **B** is mid-way between **A** and **C**. The radius of the path is  $3.0\text{ m}$  and the object moves at a constant speed of  $5.0\text{ m s}^{-1}$ .

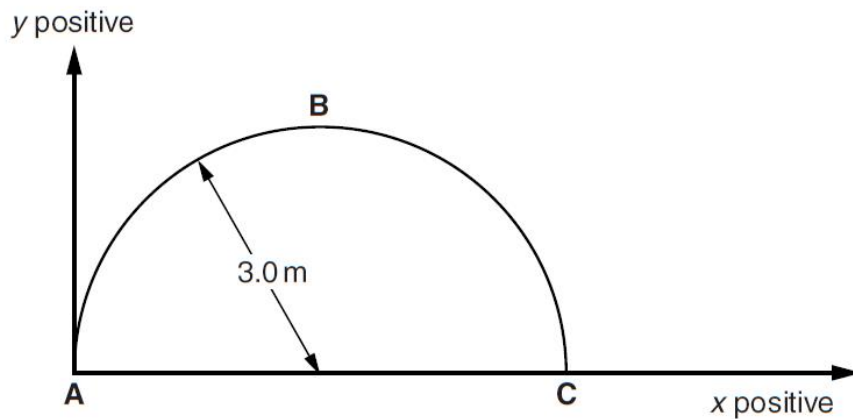

Fig. 10.1

- (i) Show that it takes about 2 seconds for the object to travel from **A** to **C**.

[1]

- (ii) Write down the values of the  $x$ - and  $y$ -components of the **velocity** of the object when at **A**, **B** and **C** in the table below.

	velocity at <b>A</b> / $\text{m s}^{-1}$	velocity at <b>B</b> / $\text{m s}^{-1}$	velocity at <b>C</b> / $\text{m s}^{-1}$
$x$ -component			
$y$ -component			

[2]

- (iii) Write down the values of the  $x$ - and  $y$ -components of the **displacement** of the object from **A** when at **B** and **C** in the table below.

	displacement from <b>A</b> to <b>B</b> /m	displacement from <b>A</b> to <b>C</b> /m
$x$ -component		
$y$ -component		

[2]

(b) A car travels around a roundabout at a constant speed of  $12 \text{ m s}^{-1}$ .  
 Its direction changes by  $40^\circ$  when moving from **D** to **E**, as shown in Fig. 10.2.

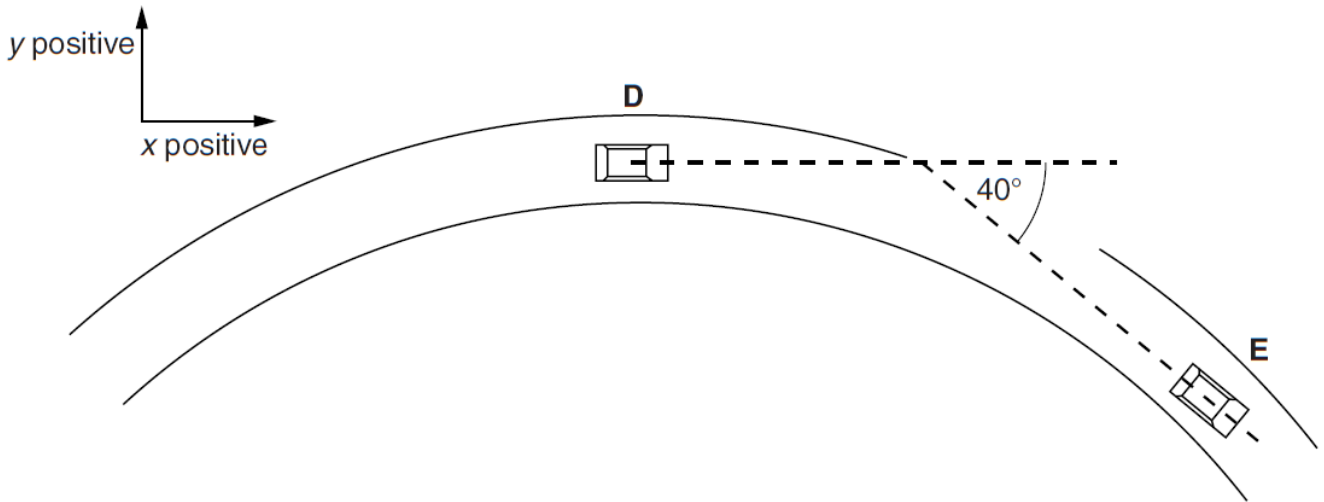

**Fig. 10.2**

Because the velocity vector changes, the car has an acceleration.  
 The car takes  $1.6 \text{ s}$  to travel from **D** to **E**.  
 Calculate the mean values of the  $x$ - and  $y$ -components of acceleration between **D** and **E**.  
 Show your working clearly.

x-component	y-component
mean x-acceleration = ..... $\text{m s}^{-2}$	mean y-acceleration = ..... $\text{m s}^{-2}$
<b>[4]</b>	

- 11** This question is about a pile-driver – a machine for hammering piles into the ground. A pile is a foundation post for a building.  
The pile-driver is attached to the top of the pile.

Fig. 11.1 shows the sequence of operations by which it hammers the pile into the ground.

**A → B** A heavy weight resting on top of the pile is lifted by a motor.

**B → C** The weight drops back onto the top of the pile.

**C → D** The moving weight pushes the pile into the ground until the weight and pile come to rest.

The process is then repeated until the pile is at the required depth.

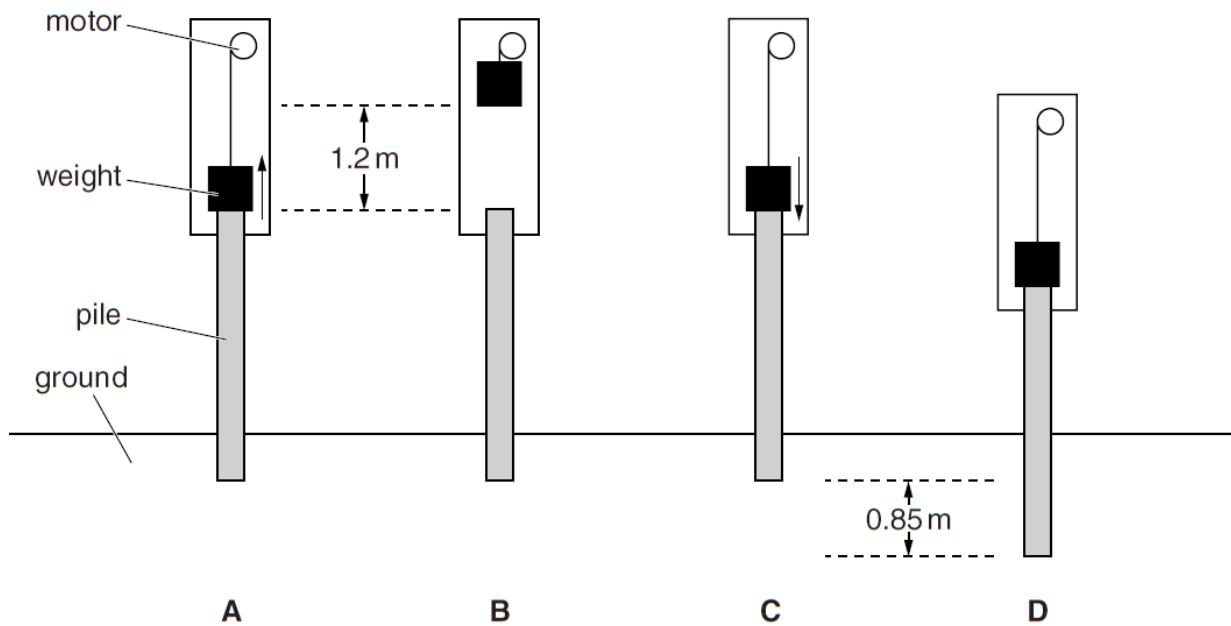

**Fig. 11.1**

- (a)** The weight has a mass of 2100 kg.  
Show that the increase in gravitational potential energy of the weight when lifted 1.2 m is about 25 kJ.  
 $g = 9.8 \text{ ms}^{-2}$

**[1]**



- (b) (i) By considering the change of gravitational potential energy of the weight between steps **B** and **D**, show that the total work done by the moving weight in falling and pushing the pile 0.85 m into the ground is about 40 kJ.

[2]

- (ii) Calculate the average force exerted on the pile as it is pushed into the ground. Assume there are no energy losses.

average force = ..... N [1]

- (iii) The mass of the pile is not included in the calculation of part (ii). Explain, without calculation, how the value for the average force would change if the mass of the pile were included.

[1]

- (c) The data for successive ‘drops’ of the pile-driver weight are shown in the table.  $d$  is the distance moved after a particular drop, and  $N$  is the drop number.

drop number, $N$	1	2	3	4
distance moved by pile, $d/m$	0.85	0.63	0.48	0.36

- (i) Suggest and explain one reason  $d$  decreases as  $N$  increases.

[2]

- (ii) It is suggested that the distance moved by the pile is given by the equation

$$d = \frac{k}{\sqrt{N}} \text{ where } k \text{ is a constant.}$$

Plan and carry out a simple arithmetic test to check if this relationship is true.

Test:	Calculation:
Conclusion:	

[4]

1 Here is a list of combinations of base units of the SI system.

$\text{kg m s}^{-1}$      $\text{kg m s}^{-2}$      $\text{kg m}^2 \text{s}^{-2}$      $\text{kg m}^{-1} \text{s}^{-2}$      $\text{kg m}^2 \text{s}^{-1}$

Choose the combinations of units for

- (a) kinetic energy ..... [1]  
 (b) force. .... [1]

2

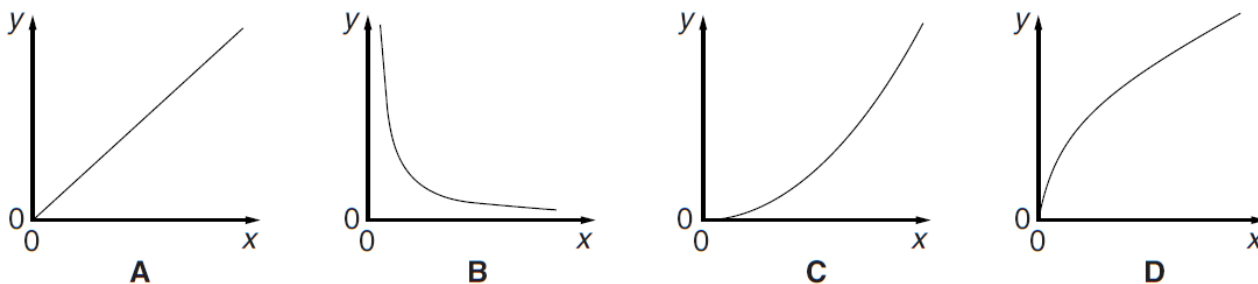

State which graph, **A**, **B**, **C** or **D**, best represents the relationship between the two quantities given in each case below.

- (a) y-axis: the frequency of a wave  
 x-axis: the wavelength of that wave  
 ..... [1]
- (b) y-axis: the kinetic energy of a moving object  
 x-axis: the speed of that object  
 ..... [1]
- (c) y-axis: the speed of an object falling from rest on Earth, assuming air resistance is negligible.  
 x-axis: the time it has been falling  
 ..... [1]
- (d) y-axis: the speed of an object falling from rest on Earth, assuming air resistance is negligible.  
 x-axis: the distance it has fallen  
 ..... [1]

3 Fig. 3.1 shows the velocity–time graph for the motion of a car.

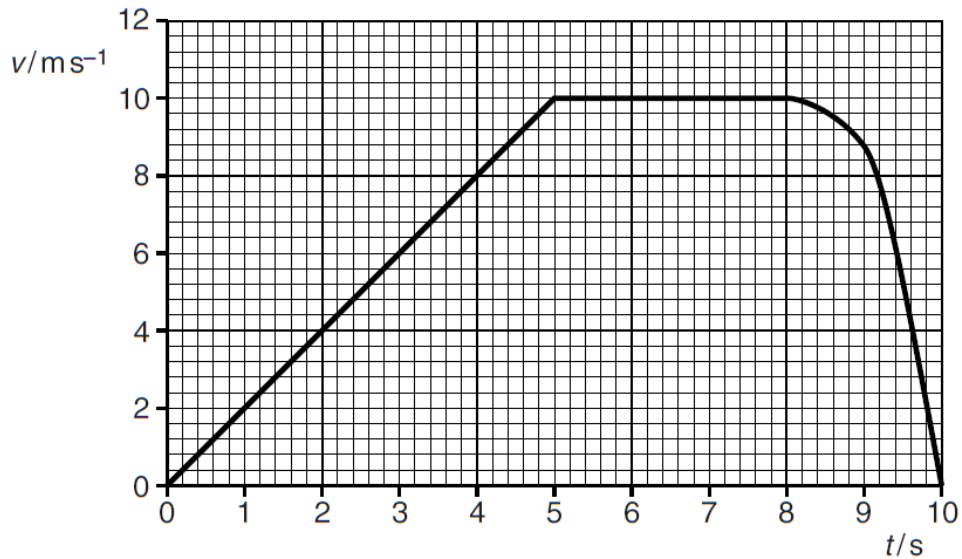

Fig. 3.1

- (a) Calculate the distance travelled by the car in the first 8 seconds.  
You should show your working.

distance = ..... m [2]

- (b) Use the graph to estimate the deceleration of the car at  $t = 9.0$ s.  
You should show your working on the graph and in this space.

deceleration = .....  $\text{ms}^{-2}$  [2]

- (c) Which sketch graph, **A**, **B**, **C** or **D**, best represents the displacement–time graph for this journey?

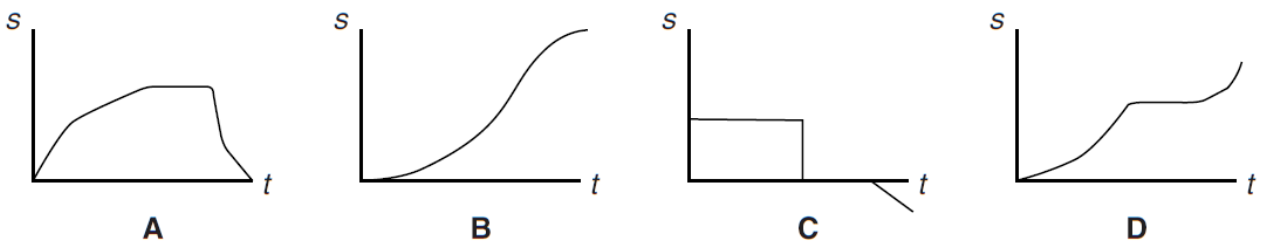

answer ..... [1]

- 8 After a natural disaster, aeroplanes are often used to drop emergency supplies to people who cannot be reached by other means. Fig. 8.1 shows the trajectory of a pack of supplies dropped in this way.

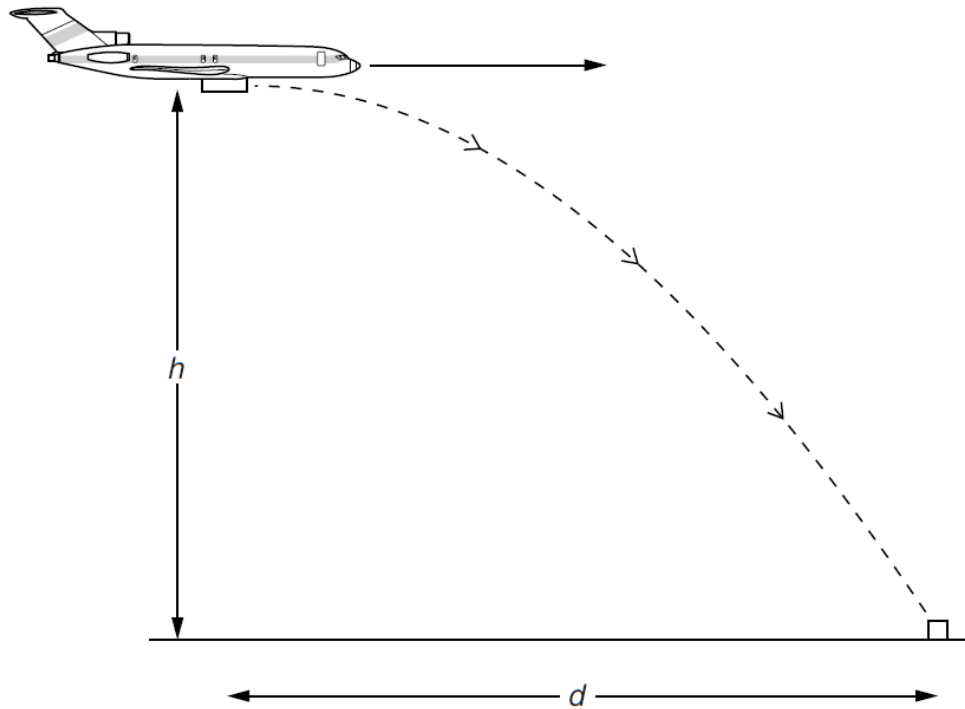

Fig. 8.1

- (a) In this part of the question, you should ignore air resistance.
- (i) Show that it would take a pack of supplies a time  $t$  of about 3s to land, falling from a height  $h$  of 50m.  
 $g = 9.8\text{ms}^{-2}$

[2]

- (ii) Explain why the horizontal distance  $d$  travelled by the pack while it falls for a time  $t$  is given by

$$d = vt$$

where  $v$  is the horizontal speed of the plane at the time of release of the pack.

[2]

(iii) Calculate the value of  $d$  for a plane travelling at a speed of  $120 \text{ ms}^{-1}$  at a height of 50 m.

$d = \dots\dots\dots \text{ m}$  [1]

(b) For certain supplies, it is essential that they land at a much lower speed, so a parachute is used.

A parachute cannot be used for a pack dropped from heights below 200 m.

Suggest an item which would need to be dropped by parachute. Discuss why using a parachute and dropping the pack from a height above 200 m might prevent the pack reaching its intended destination.



*In your answer you should consider different factors which may prevent the pack reaching its intended destination.*

[4]

11 This question is about a helicopter.

- (a) The helicopter has a mass of 9500 kg. Show that the upward force that the rotors must provide to keep the helicopter hovering at a constant height is about 90 kN.  
 $g = 9.8 \text{ ms}^{-2}$

[1]

- (b) The helicopter is tilted as shown in Fig. 11.1 so that it can move horizontally.

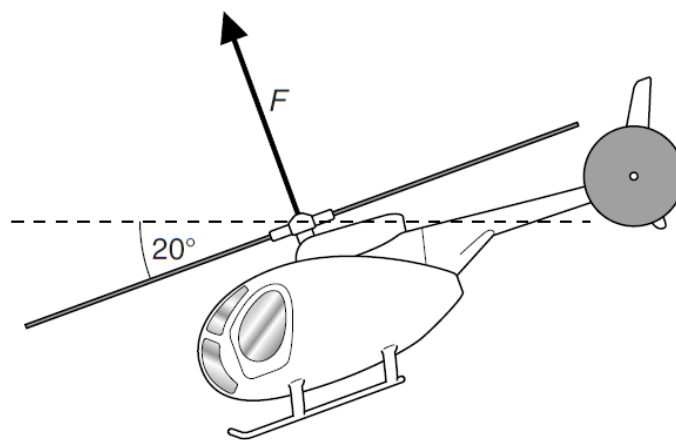

Fig. 11.1

- (i) Draw a vector diagram, showing the horizontal and vertical components of the force  $F$  when the helicopter is tilted at an angle of  $20^\circ$ . Label each component with its value in terms of  $F$ .

[3]

- (ii) Use the vector diagram to show that the force  $F$  required to keep the helicopter at a constant height must now be nearly 100kN.

[2]

- (iii) Use the vector diagram to calculate the initial horizontal acceleration of the helicopter.

acceleration = .....  $\text{ms}^{-2}$  [2]

- (c) The helicopter can travel at a constant horizontal velocity of  $24 \text{ m s}^{-1}$  in still air. The helicopter is heading due north. There is a side wind blowing due east with a velocity of  $9 \text{ m s}^{-1}$ .

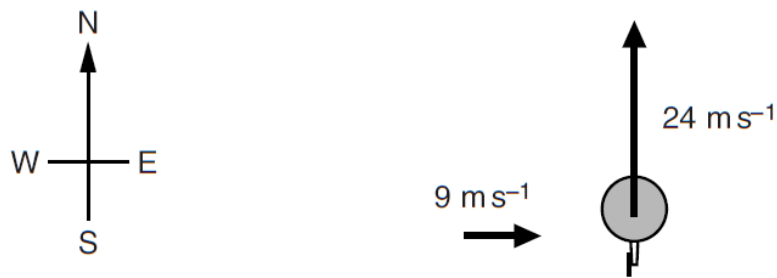

view from above

Calculate the resultant velocity of the helicopter relative to the ground.

magnitude of velocity = .....  $\text{m s}^{-1}$

direction = .....

[3]



1 Here is a list of units.

$\text{ms}^{-2}$

$\text{kgms}^{-2}$

$\text{Nkg}^{-1}$

$\text{Nm}$

$\text{Js}^{-1}$

Choose the correct units for

(a) energy

..... [1]

(b) power

..... [1]

(c) force

..... [1]

2

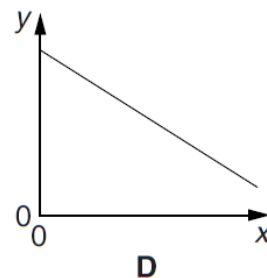
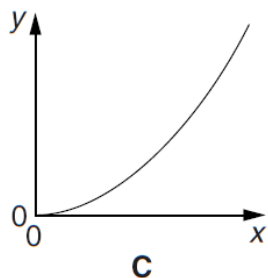
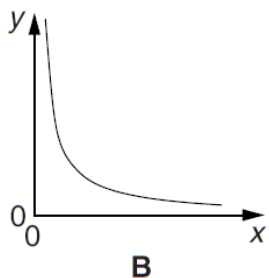
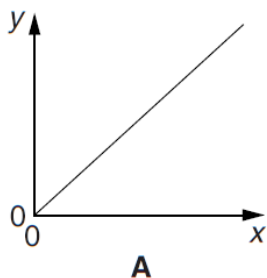

Which graph, **A**, **B**, **C** or **D**, is obtained when the *y*- and *x*- axes represent the two quantities given in each case below?

(a) *y*-axis: the potential energy gained when an object is lifted a given height  
*x*-axis: the mass of the object

..... [1]

(b) *y*-axis: the distance moved by an object accelerating at a constant rate from rest  
*x*-axis: the time for which the object has been accelerated

..... [1]

(c) *y*-axis: the energy of a photon of electromagnetic radiation  
*x*-axis: the wavelength of the radiation

..... [1]

6 Fig. 6.1 shows the forces acting on a car of mass 1940 kg travelling along a horizontal road.

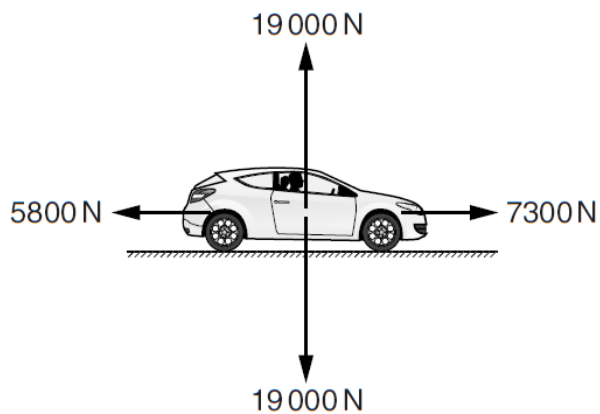

**Fig. 6.1**

(a) Find the resultant force acting on the car.

magnitude = ..... N

direction .....

**[2]**

(b) Calculate the magnitude of the acceleration of the car.

acceleration = .....  $\text{m s}^{-2}$  **[2]**

(c) At the instant shown in Fig. 6.1, the car has a speed of  $22 \text{ m s}^{-1}$ .  
Calculate the power dissipated against resistive forces at this instant.

power = ..... W **[2]**

7 Professional footballers can kick a football at speeds greater than  $35 \text{ ms}^{-1}$ .



Fig. 7.1

- (a) A footballer kicks a stationary football. The foot and the ball are in contact for about 0.05 seconds. Immediately after contact, the ball is moving at  $35 \text{ ms}^{-1}$ . Show that the mean force applied to the ball is about 300 N.

mass of football = 0.44 kg

[3]

- (b) The force  $F$  on the ball is not constant, but varies with time  $t$  as shown in Fig. 7.2.

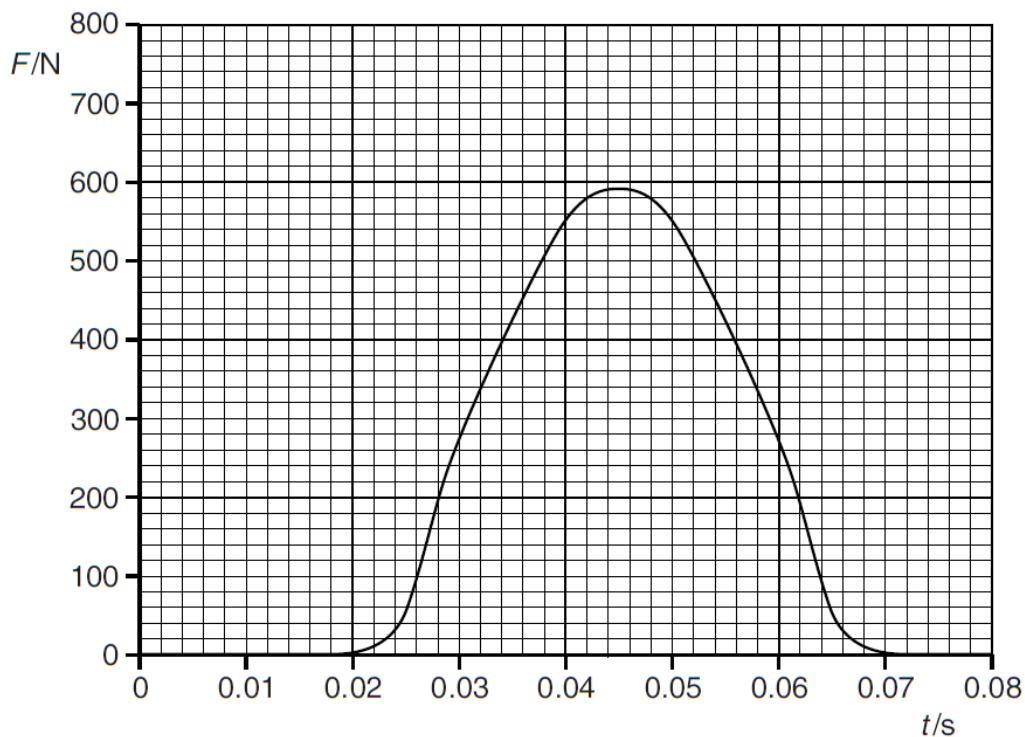

Fig. 7.2

© OCR 2012

Use data from the graph to show that the maximum acceleration of the ball is about  $140g$ .  
 $g = 9.8 \text{ ms}^{-2}$

[3]

- (c) On the axes of Fig. 7.3, sketch carefully the velocity-time graph for the football kicked at  $35 \text{ ms}^{-1}$ . No calculations are needed.  
The variation of force with time is indicated by the dashed line.

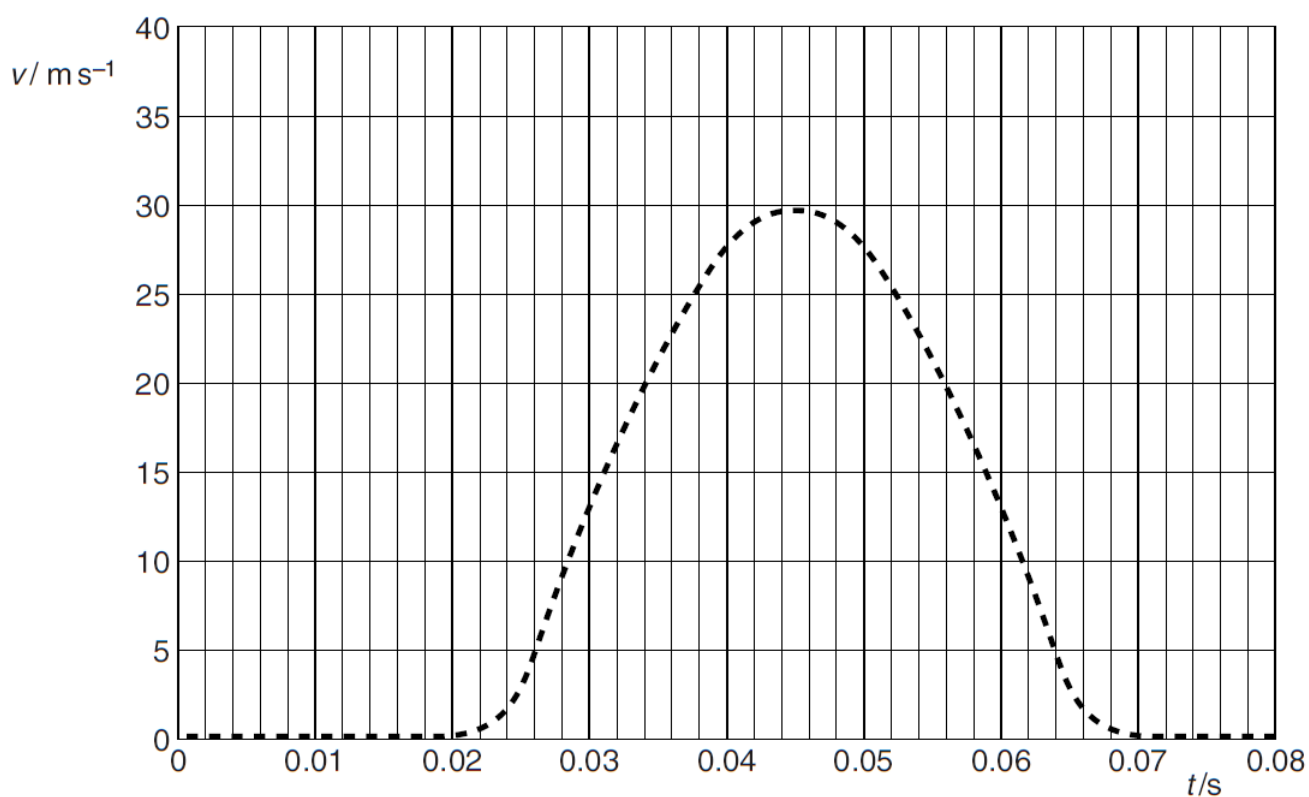

Fig. 7.3

[4]

June 2013 G492 Q9 is also a Space time and Motion question but there is no room here.